



AVALI



A COMPREHENSIVE GUIDE

WRITTEN BY
TODD AVALI

ILLUSTRATIONS BY
TODD AVALI

ORIGINAL SPECIES BY
RYUJINZERO

PUBLIC EDITION

20240501

[תמונת איור של פריט ייחודי]

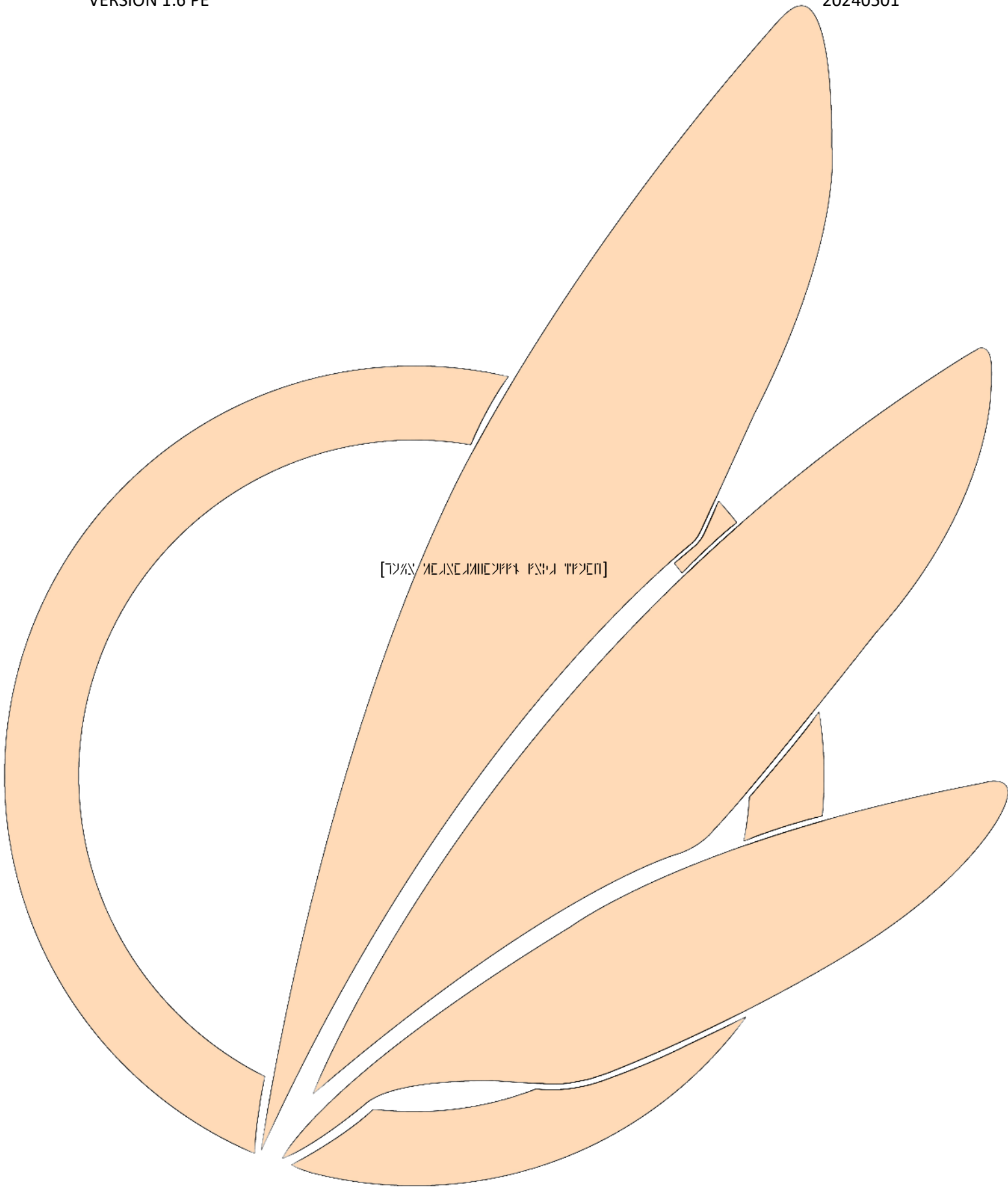

Todd's Book of

AVALLI

A Comprehensive Guide

PUBLIC EDITION

Original Concepts and Species by RyuujinZERO

PREFACE

The Avali and their associated lore and foundations conceptualized belong to their respective owner, RyuujinZERO. While this book is based on the subject matter, it should not be construed as official lore. This book aims to take the already shed principles and concepts of the Avali lore, as written and discussed by Ryuujin, and consolidate them into one place. Additionally, this book's author, editors, artists, and respective participants have carefully refined and further developed the lore, expanding upon what was already established. Due to the nature of this, nearly all original concepts remain the same, with only two major alterations. The core temperature of the Avali was changed from -30C to -2C, with their body solvent becoming a mixture of ammonia and water. This was done to give Avali a better operational range, push them out of the near-boiling range for pure ammonia, and avoid freezing with pure water. Additionally, this change gives the added benefit of a more efficient energy transfer, thanks in part to the added heat.

This book was written, illustrated, edited, and reviewed by volunteer members who admire and are interested in its respective concepts. While the original creator did not participate in the development and implementation of some of the topics in the book, all subjects discussed in the book are made with the creator's ideas and wishes in mind, and we worked tirelessly within the established parameters of the original concepts.

The book is a living document. The topics discussed within the can will be subject to change or removal. Alterations will be identified within the guide with a bold black line (see example on the side) within the margin of the page, either on the left or right side of the

affected paragraph. A summary of changes will also be provided, located before the Table of Contents. Version numbers go in ascending order, starting at 0. All previous editions will become obsolete after the most up-to-date edits are released. The version edition is located at the top left-hand corner of each page. This document has two variants: a public edition and a supporter edition. Each version will be identified with a two-letter code at the end of the edition number, either a "PE" or a "SE," respectively. Draft editions will be identified with a "D" at the end of the version edition identifier code. The publication date is located at the top right-hand corner of the page.

If you, the reader, discover an issue or have a concept that you believe would fit within the lore guide, you can submit your idea to the creators of this book, and it will be reviewed. This does not guarantee the inclusion or certification of your concepts in the guide. Alterations made outside of the will of the author, illustrators, or editors are strictly prohibited.

Thank you for taking the time and reading our product. We hope you find it informative and insightful on the subject at hand. Once again, we would like to reiterate that this is NOT official lore.

CREDITS

Concept Creator: RyuujinZERO

Project Lead: Todd Avali

Development: Todd Avali

Lead Illustrator: Todd Avali

Lead Editors: Ranade Empor, Hetuni Jakhal

Editors: Wyatt R., Aria Avali, APersonThatIs, Alkac, Tuidog, Stop_Watch, Beanthusiast

Lead Subject Matter Expert (SME): Hetuni Jakhal

SMEs: Ceital Tesai, Yoki, Nemo_curat

Photography: Misty Jinn, NTM

Avali scratch font: Icebelly and Someguynameddavid

Avali Number System: Ceital Tesai

3D Avatar Models: Javenchi, Rai Kitamatsu, Rosebur

Special thanks to the following: Viinazyl, F0xRa1n, Altair, Rhaaka, Cynadyde, Flute, Rukiiuu, Very Confused Dragon, Jhin Wonderlust, K'Braid, Patchi, Kuno Avali, Aipi, Zentimental, Kobalstromo, Stop_watch, Misty Jinn, Nesi, Cody Egg, NTM, Nidobun, Khaali, ThekingofApples, HyoPone, VTWuff, ZetraThorn, Niviru Tenrra, SedrinTheStar, Nicolain08, Dimi Stella, Nirvash, Kumiho, Duwa Avali, Tibaes, Cleafspear, Linux Avali, Sweetie Heartcould, Curus Keel, Ei'Kuni Zesun, Fuarthain Fuar, Ignus vam, SAM, kobolds Kobolds KOBOLDS, YasherFox, Tholin, Datalink, Minius Areas, Webserfer, Meagan Harris, Iyuman, Linux Avali, Beanthusiast, Matthew Akin, Spyrour, Michiru Ya'Mila, River, Kumiho, HTFCuddles, Aden Silvertooth, Vultu2e, Luna Avali, Florian Grille, Ignus Vam, Jonas Schizelburger, Tomae Satpotov, Rhyzal the Avali, TaleSter, Kaya K,

Nightslasher, Keiko Shard, Rogue Shadow-Walker, Zandario, Aden Silvertooth, Ei'Kuni Zesun, Amanda Yuki, Humble Note, Matthew George, Fuarthain Fuar, Happyrobot33, Mayore, Star, Raisor the Avali, Sammy Raeh, Rikuu, Fortspace, Rosebur, Javenchi, Magnus, Vlademanuel, Max Breinholt, Renali Keliune, Cl3nr C2, Youkai Jesus

Special message: Renali Keliune is canonically cute.

SUMMARY OF CHANGES

- Updated the supporters under “Credits”
- Changed the cover
- Added “cuteness” to the Avali.
- Chapter 1 Section 2 “Biology”: Added Immunoresponse systems
- Chapter 1 Section 2 “Biology”: Added additional information about respiratory systems.
- Chapter 1 Section 2 “Biology”: Added additional information on hearing and echolocation
- Chapter 1 Section 2 “Biology”: Added additional information regarding hands, feet, wings, and legs.
- Chapter 2 Section 3 “Beliefs and Behavior”: Added clothing beliefs and usage
- Chapter 2 Section 5 “Technology”: Added architecture and infrastructure.

Note: Due to a large amount of content and limited time, many parts of the book do not have pictures or references attached to them. In turn, there will be periodic updates to the book adding new pictures. New pictures will be identified with the black bar system.

Note: This is the “Public” edition. Some content was removed and can be found in the “Supporter” edition of the book. To find out what was removed and obtain access to the Supporter edition, donate to Todd Avali via Patreon or Ko-Fi, or contact the author for information!

TABLE OF CONTENTS

PREFACE	iv	Skomar (Skamar).....	25
CREDITS	v	Yellow Eyes (Krr’Ayusk).....	25
SUMMARY OF CHANGES	vi	Elysium (Eirkleesm).....	26
CHAPTER 1 ICE AND FEATHER	1	Midnight Star (Suresk’Brk).....	26
ICE AND FEATHER.....	2	Luka (Lieka)	27
Origins	2	Rhyes (Rwehces).....	28
A Galaxy Awaits.....	3	CHAPTER SUMMARY	29
BIOLOGY	4	Chapter 2 AVALIAN CULTURE.....	31
Size	4	Strength through Unity	32
Feathers	4	HISTORY OF AVALIAN SOCIETIES.....	33
Chemistry Make-up.....	6	Formation of Societies.....	33
Respiratory and Circulation	6	The Illuminate	36
Eyes	8	Independent Tribes.....	39
Hearing.....	9	Rogue Tribes and Colonies	39
Emotions	10	BELIEFS AND BEHAVIOR	42
Smelling.....	10	Thought Processes	43
Brain	11	Expressions and Social Dynamics	44
Skeletal Structure.....	12	Hatcheries.....	47
Digestive Tract	13	Avali Kits.....	48
Wings and hands.....	14	Pack Bonding and Loss.....	49
Feet	15	Arts.....	51
Skirt and Tails	16	Foods and Culinary	52
THE HOMEWORLD OF AVALON	17	AVALI LANGUAGE	55
Atmosphere	17	Avali Scratch	55
Surface	18	Avalian Core Language.....	55
Biomes.....	20	TECHNOLOGY	62
Creatures.....	22	Civilization Without Fire	62
Moon Composition	23	Augments.....	64
THE URESK STAR SYSTEM	24	Clothing.....	66
Uresk	24	Drones and Vehicles	68
Mortus (Mtrus)	24	Medical Nanites	71
		Farming and Food Supply	73

Architecture	74
Infrastructure	76
Other Engineering Marvels	77
Nexus Central Network System	79
Oracle AI Assistant	79
MILITARY AND WEAPONRY	81
Melee Weaponry	82
Ranged Weaponry.....	83
Military Drones	84
Armors and Equipment	85
Military Vehicles.....	87
Tactics and Doctrine.....	90
Military Service and Structure	91
SPACE EXPLORATION.....	94
Colonies and Habitats	95
Technology.....	96
Fleets.....	100
Diplomacy	103
CHAPTER SUMMARY	105
Chapter 3 AVALI AND YOU	108
AVALI AND YOU	109
Creating a Personal Avali	109
Design.....	110
Established Universes	114
Statistics and Traits	115
STARBOUND UNIVERSE.....	120
AVALI OUTSIDE OF STARBOUND.....	121
CHAPTER SUMMARY	123
RESOURCES AND CONTACTS.....	124

ICE AND FEATHER

CHAPTER 1



ICE AND FEATHER

Nestled next to a gas giant, an unassuming icy moon known as Avalon stirs quietly with activity. The thick clouds shroud the cold rock from the outside, but the world churns away. Life flourishes within the dark, cold moon, both familiar and alien. Indeed, life had found an unusual spot in the large galaxy. The moon turns as the creatures that inhabit it continue about their day, none the wiser, as this has been their home for eons.

The clacking of talons and fluttering of feathers can be heard, muted only by the wind and the swaying of alien plant life. Creatures scurry across the ice and snow, followed by machines of steel and plastics. Technology, whirring calmly across the world, thoroughly cemented and operated by a small race of ice raptors who call themselves Avali.

The Avali continue about their day, no different from any other. The inhospitable cold means nothing to them. The Avali push through the sharp winds and dense snow as if it wasn't there. They live here. They evolved here. To them, it's like a warm day at the beach.

The Avali are small, feathered creatures that evolved to have complex problem-solving skills. Resembling a lot like raptors, Avali also have two pairs of ears, which they use to navigate their world. While they have eyes, their primary sense involves their ears. These ice raptors are frequently found in packs. They have developed and harnessed technologies that have pushed them into space, allowing for the extraction of resources within their star system. Their cute appearance has made them unassuming to most onlookers; however, their razor-sharp talons and teeth are not to be underestimated.

ORIGINS

The Avali (plural "Avali," adjective "Avalian") and their concepts were created by RyuujinZERO. Initially created in the EA-Maxis' game "Spore," the race was originally known as lubati, based on the Latin word meaning "crest" or "crested." Their first sight was seen in early 2009 and published in "Sporepedia." Ryuujin would start to lay the foundations of the frozen home world, the heavy use of technologies and artificial intelligence algorithms, and some vehicle concepts that the lubati utilized. Here, the original ideas of Avali can be seen.

As the development continued in the lubati species in 2010, Ryuujin would later split the lubati species into two subraces, the Elysiii and the Avali. While essentially identical and interchangeable, the critical differences between the two races are the core sectors in space in which they evolved in and their cultures.

The adventure story was built using the EA-Maxis' "Spore: Galactic Adventures" expansion pack. Later, Ryuujin would make a custom story mission in Spore known as "Whom Gods Destroy." The story itself, a Sci-Fi Horror-Tragedy, puts a player into a captain's perspective, searching for artifacts on a barren world, only for their little adventure to go awry.

In 2014, Ryuujin would begin the development of a new race for the upcoming Chucklefish game "Starbound." She would use the Avali concepts from "Spore" and continue the development of the species. In "Starbound," the Avali would see the development of their society and pack systems, diets, culture, and biology. On April 2014, Ryuujin released the Avali mod for "Starbound."

A GALAXY AWAITS

Today, the Avali fandom continues to keep the species alive. A small community has developed around the little ice raptors, partly thanks to their cute appearance and online presence. Multiple game mods and adaptations have also incorporated Avali into new stories and adventures. Additionally, the fandom has continued to create fan art and stories involving race.

Official development of the Avali race has stagnated since its peak in 2015. Although not abandoned by Ryuujin, her priority for the race is not as significant as they were during the initial "Starbound" development periods. In response, the community has slowly continued their development of the species, creating alternate lore and cultures for the Avali. The openness of the race allows for it to be mingled into otherwise prohibitive universes.

While this book is a comprehensive guide to the species, it is not official lore. The Avali lore is compiled into chapters and sections in this book. Each section will break down and explain certain aspects of the Avali from a subjective viewpoint and in intricate detail. Additionally, the development of the species will continue further, following closely in the footsteps of Ryuujin.

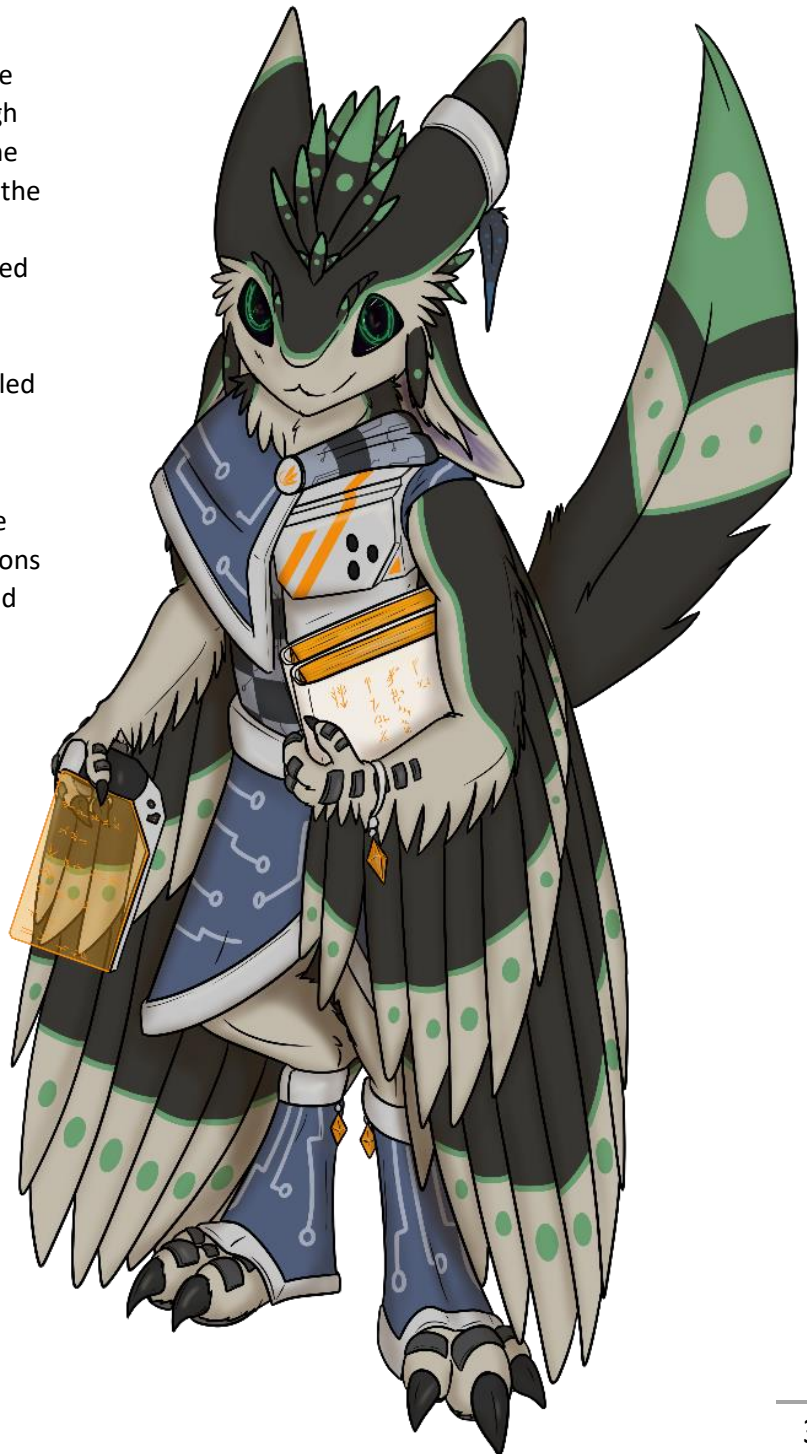

BIOLOGY

Avali are sapient, technologically-advanced alien creatures originating on the moon Avalon. Their appearance resembles closely to an Earth-based, Cretaceous period Deinonychus. Avali are fully feathered, bipedal creatures with distinctive large eyes, four rabbit-like ears attached to their head, and two wings with three dexterous digits, capable of manipulating objects. They are unassuming at first glance, with a nonthreatening appearance to humans. On Avalon, they evolved to be excellent fliers. Despite their large brains and flying capabilities, metabolic rates for Avali are slow compared to humans, tied to the cold natural temperatures of Avalon. On average, the weight of Avali is about 27-31 kg or 60-68 lbs.

SIZE

Compared to Humans, Avali are relatively small. Regardless of sex, the average adult height ranges between 100-120 cm or 35-43 inches. If you were to lay one out from head to tail tip, Avali are 120-150 cm, 47-59 inches in length. Although small, Avali evolved into the "Apex" predators or "Super-Predators" of their home world. Formidable on land and air, their powerful legs, well-developed wings, and excellent cognitive abilities and pack tactics have allowed Avali to reign unchallenged in their home world. The legs evolved to enable a good balance between agile mobility and speed on the ground. With talons on their feet, traversing through and climbing on foliage can be done quickly. This has also lent itself to decent carrying capabilities. Avali have exploited this for help with hunting and gathering through trees and bushes, carrying back food to their nests.

Flight is one of the most common ways traveling is done. Avali are also known in their home world for their exceptional ability to fly

and navigate through the dense air. Cities and hunting grounds are designed and adapted in ways to accommodate Avali flight. However, most goods are embarked on drone-based or manually controlled vehicles on land, sea, and air. Their wings are less functional on other planets but allow for low-level gliding and slowing falls. Avali rely more on drones and vehicles to navigate through these environments.

FEATHERS

Like Terran birds and other ave-formes, Avali possess a range of specialized feathers. The upper and outer parts of the body are contour-style feathers. These feathers are slicker and naturally oiled to protect from snowfall. Oil glands are found around the top of the head, armpits, and on upper parts of the pelvis. During idle periods, Avali can be seen stroking their head, arms, and pelvis, spreading the oils across their feathers. Some pack activities also include rubbing and brushing the outer feathers. These activities also allow for removing loose and molting feathers.

The longer contour feathers, such as those on the wings and crest, have a healthy blood supply at their roots. These feathers are known to bleed profusely if removed forcibly. Feathers lost in that way will regrow after several weeks.

The lower and inner parts of the body contain lighter, fluffier-style feathers, assisting in the body's insulation. These feathers, also known as "pulviplumes," are specialized down feathers that regenerate continuously. The outer barbules break off and help to oil and powder the other down feathers, keeping them in pristine condition.

The more giant contour feathers respond well to heat application, taking on near-permanent new forms. This is a common way of individualized styling. Notably, the crest

feathers atop their head are used for this, allowing for a distinctly unique look.

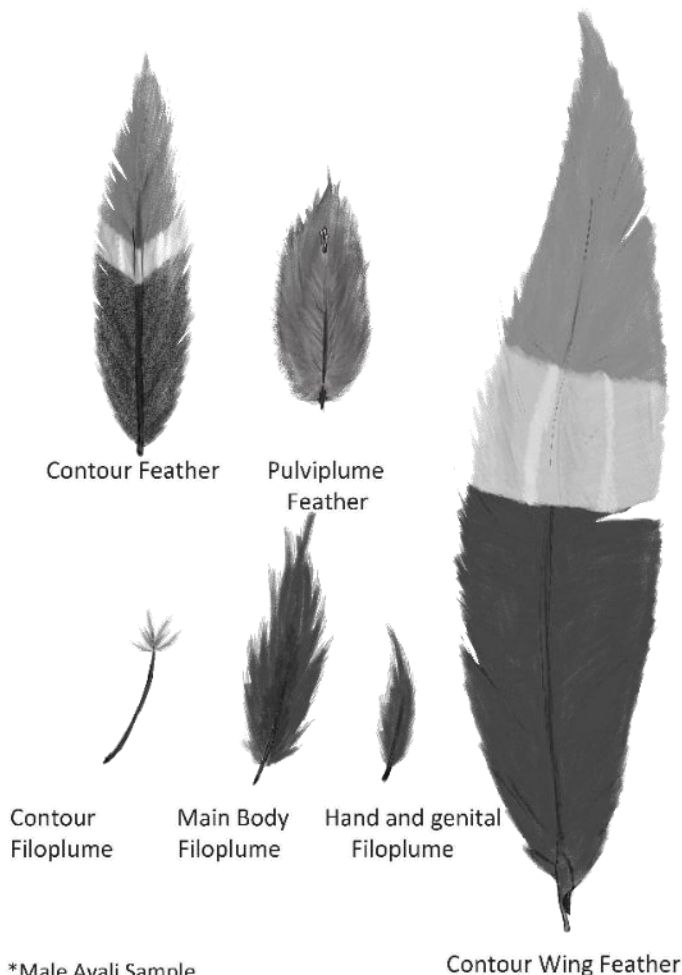

*Male Avali Sample

Figure 1-Feather Examples

The tip of the Avali snout contains a set of thinner, finer barbed feathers. These unique feathers evolved to allow heat to reach the skin of the muzzle, mainly used to detect the heat of eggs. Similarly slick to the adjacent contour feathers but less insulating, these feathers allow the temperature to pass through more easily.

Filoplumes, specialized feathers with nerve endings, can be found in the Avali's body. Certain areas, such as the wing digits and ears, have heavier concentrations of these feathers. The feathers have two distinct styles, functioning similarly, though one is more sensitive than the other. The longer, more

narrow style of feathers is found throughout the main parts of the body, wings, and tail tips.

The smaller, slightly wider, and more sensitive feathers can be found along the fingers, genital areas, inner thighs, underside of the tail, ears, and front parts of the face.

They are relatively uniform in their colors and only possess small amounts of sexual dimorphism between males and females. For outsiders, this makes them almost indistinguishable from one another apart from their markings and genitalia. Natural tones include white, grays, and slate, with soft, muted Earth tones, such as browns, greens, and tans. Male Avali can be identified by brighter, near-iridescent bands of color around their body. Females have muted, two-toned feathers, often with speckled patterning.

Feathers molt continuously throughout an Avali's life. Depending on the type of feather, replacements take 3-6 weeks to fully grow in. Molted feathers are often duller in color or damaged in some way. Avali who live in the colder parts of their home

Figure 2 - Huntress Avali



world will have larger molting seasons lasting 6-8 weeks, twice a year, alongside their regular continuous molting.

CHEMISTRY MAKE-UP

At the core, Avali are a carbon-based creature that has evolved on a frigid planet with low light. Their blood is a mixture of water and ammonia. It's based heavily on copper, instead of iron, at 2:1. This results in their blood and flesh a purple to pale-purple hues. For breathing, an oxygenized environment is required for survival, with no less than 18% enrichment. Furthermore, Avali need to be in climates with cold temperatures, with the operating range being -35°C to 2°C, or -31°F-37°F. The core body temperature for an Avali is close to -7°C.

Avali have evolved in an atmosphere much denser than Earth, approximately two times thicker in most areas. Consequently, specific boiling points of chemicals have been raised, allowing lifeforms on the planet to evolve, including the Avali. When Avali travel outside their home planet, specialized environmental suits must be worn to maintain the high atmospheric pressures.

Although from a cold planet, Avali are warm by the standards of their world. They are endothermic, meaning they use a good deal of their metabolism to generate their heat. This trait is necessary for being able to fly in their world. Still, despite being warmer than most, their metabolic process is slow. Avali sleep multiple times throughout the day, working in short bursts. The average Avali will sleep 7-8 hours total per day. They also commonly sleep in packs, sharing each other's warmth to conserve energy further. Due to their low metabolic rate, the average lifespan of an Avali is between 200-250 years relative to their home planet.

RESPIRATORY AND CIRCULATION

The lungs of the Avali have two main parts: an upper, denser air sac and two larger air sacs. The upper air sac is used primarily for ground and idle activities. Air is breathed in either or a combination of the rear airways in the back, between the ears, and the mouth.

The air passes through a densely packed bronchus, absorbing oxygen. A pair of larger bronchus extends out from the primary upper lung to 2 larger secondary air sacs. The primary functions of these lungs are to fill with air, to allow for better flight capabilities, and to dissipate heat generated through the intense exercise of flight. The lungs are slightly filled during rest periods and mild activities. In contrast, during flight or intense workouts, the lungs will be constantly filled in such

periods to allow for better oxygen absorption. These secondary lungs contain groups of para bronchi, allowing continuous oxygen absorption during flight. When these lungs become

inflated, the Avali will look puffed up as their chest expands outwards.



Figure 4 - Respiratory System

Figure 3 - Avali Heart (top), Blood cells (bottom)

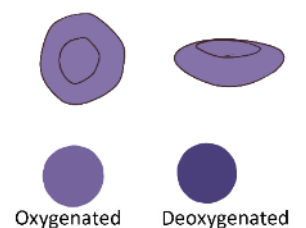
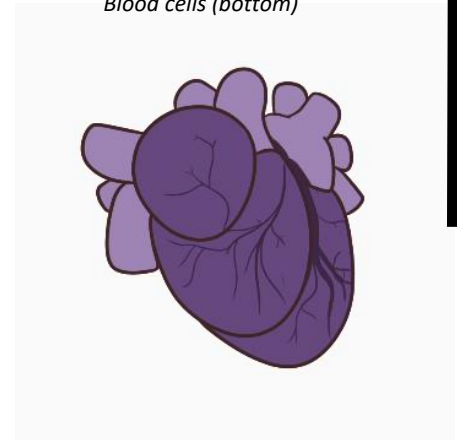

An Avali's heart is four-chamber style, like the ones found on Earth. Its blood cells are slightly hexagonal shaped, though still rounded. The heart has two upper, smaller atria, leading into two larger ventricles to build pressure. Unlike birds, Avali possess a set of complex kidneys and a bladder to remove excess water, ammonia, nitrous waste, and other unwanted toxins.

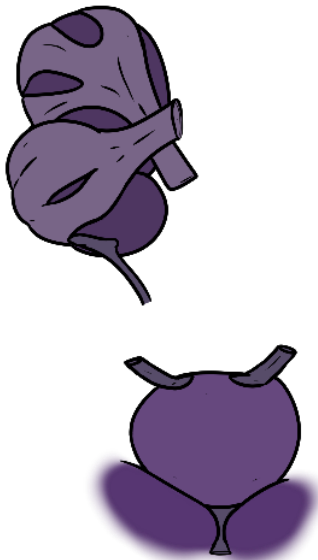

Figure 6 - Avali Kidney (top left), Bladder (bottom left), and cardio-respiratory system (far right)

The immune system consists of multiple passive and a multi-tiered immune response system. Passively, Avali secrete tears, mucus for specific openings, saliva in the maw, and urine to flush out their cloacal opening. These passive immune response systems have a generic antibody secreted by the Avali, which will quickly bond to foreign objects. These allow for the immune system to respond to a threat automatically. Their feathers and skin also provide protection against the elements. A multistep autoimmune system activates when infected with an antigen, such as bacteria, fungi, and viruses. The primary response system consists of three immune cells identifying, registering, and attacking the antigen. This primary response consists of macrophage- and neutrophil-type cells that respond immediately to the threat. The secondary system, which is much more aggressive, consists of two types of active immune cells attacking, which are either an "A" cell or a "B" cell, plus a "C" cell. This phase also causes mild fevers and inflammation. The tertiary system is found to collect any leftover antigen debris and relocate expired



immune cells to the spleen. They also continue to affect the afflicted area until 15-20 days have passed.

The three active immune cells can be intensified as A, B, and C lymphocytes. "A" cells are the primary attacking cells. They search for a hook-shaped antibody molecule that binds with the antigen. They attack and consume the target,

overwhelming it with enzymes and proteins. The secondary cells, "B" cells, attack and latch onto large antigens, like fungal, parasitic, etc, dissolving an outer barrier and breaking them down, allowing the "A" cells to consume the large body. The "C" cells are memory and testing cells. These particular cells can register possible threats and signal the immune response system. These cells attach themselves to foreign objects and deposit antibodies for the other cells to attack. They are always present in the bloodstream, unlike the other two cells, which reside in the lymph nodes of an Avali.

Figure 5 - Avali Immune Cells

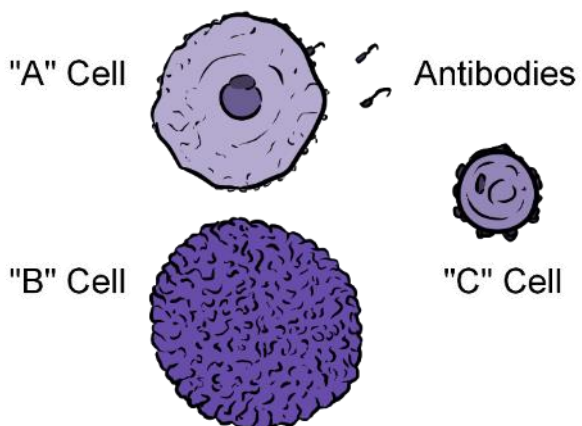

EYES

Avali eyes are large and distinctive. However, their eyesight is very poor compared to humans. Their eyes are shallow and contain a very narrow lens. These, coupled together, allow for light sensing and sight just good enough to identify close objects. Their poor eyesight results from the low light conditions of their home world and does not favor the evolution of much more than rudimentary sight. Their eyes are not as reflexive as Human eyes, although slight movements are possible. As Avali evolved, they became more reliant on their eyes to identify and craft tools. As a result, eyes are known to be the most commonly cybernetically enhanced part of the Avali to compensate for their evolution's shortcomings.

The eyes are kept moist through two small tear ducts located at the sides of the eyes. These ducts secrete an ammonia solution, which spreads across the eyeball with movement and with the eyelids. Tiny fine barbs at the eyelids' edges are used to deflect dust particles. Captured particles are removed from the ammonia tears or through wiping of the eyes. During periods of extreme weather instances, Avali will often keep their eyes closed, protecting them from the elements.

Avali can see colors, despite the limitations of their eyes. Infrared light is focused on more than others, with wavelengths 590 nanometers (nm) to 1530 nm, due to the limited light spectrums reaching the surface of Avalon. Seeing these light spectrums allows Avali to easily distinguish each other by specific natural patterning on their feathers, such as iridescent bands. Without external peripherals, these patterns would not be easily visible to a human.

The eyes appear primarily dark grey or black to the average human. The construction of the eye is unlike those on Earth. The Cornea is entirely opaque, with a purplish hue in the correct light. The pupil is somewhat slit/octagonal-like, completely dark. The retina contains fine, circular-like bumps, which allow for the detection of light and form color pictures. Avali eyes have a retroreflective inner eye, giving them a faint low-light glow, often seen as a light gray color. Consequently, this trait also further hinders the eyes' focusing ability.

Figure 7 - Avali Eyes. Bottom left showing the light reflection of the inner eye.



Figure 8 - Avali Ears

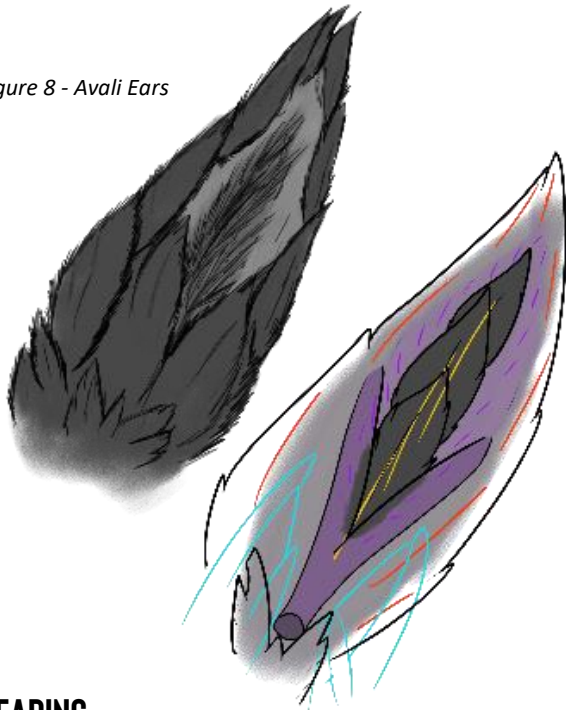

HEARING

By far, the most distinguishing features of an Avali are the ears. Four large, articulated ears and an enlarged hearing sensory lobe in their brain give them exceptional hearing abilities. The top 2 ears on the head are capable of 180 degrees of rotation, facing forward and backward. The natural resting position is pointing back and slightly downwards. The lower ears are not as flexible; however, they are flexible enough to receive additional auditory signals. The natural resting position of these ears is facing forward and resting on the shoulders of the Avali. Each of the ears can be individually manipulated.

Hearing is the primary sense Avali utilize. A good proportion of their society and life revolves around hearing. Even in the dark, where eyesight is not remotely feasible, Avali can still navigate life through echo-location, using sounds they generate, like purring or soft squeaks. Special feathers within their ears allow them to detect pressure differences around them, giving them a sense of rudimentary object location. These feathers are mainly used to avoid traversing into walls or off steep heights and are attached to

long roots nourished by blood vessels and connected to nerves that link through the skull and brain. Vibrations are transmitted through the barbs of the feathers and down the root. The frequency of the vibrations is processed in the brain. This allows for an Avali to “see” in areas that otherwise would be impossible with standard vision, such as around corners, deep in caverns, or even on other levels of a building.

The brain's auditory processing center is also enlarged compared to most animals. This allows for dedicated and isolated processing of inbound auditory signals. With their exceptional auditory evolution, Avali can hear sounds as low as 5 Hz and as high as 50 kHz. Their processing center can quickly and easily differentiate sounds, track distances, and even isolate certain wavelengths of sound. Avali use their top ears for tracking and distance hearing. Their bottom ears are used for shorter distances and close conversations. The ears will often lock on to a point of interest, such as listening to conversations, music, tracking animals, etc. Due to their echo-location abilities and being their primary sense, the ears of the Avali are very sensitive to touch.

Figure 8 – Avali Inner Ear Feather

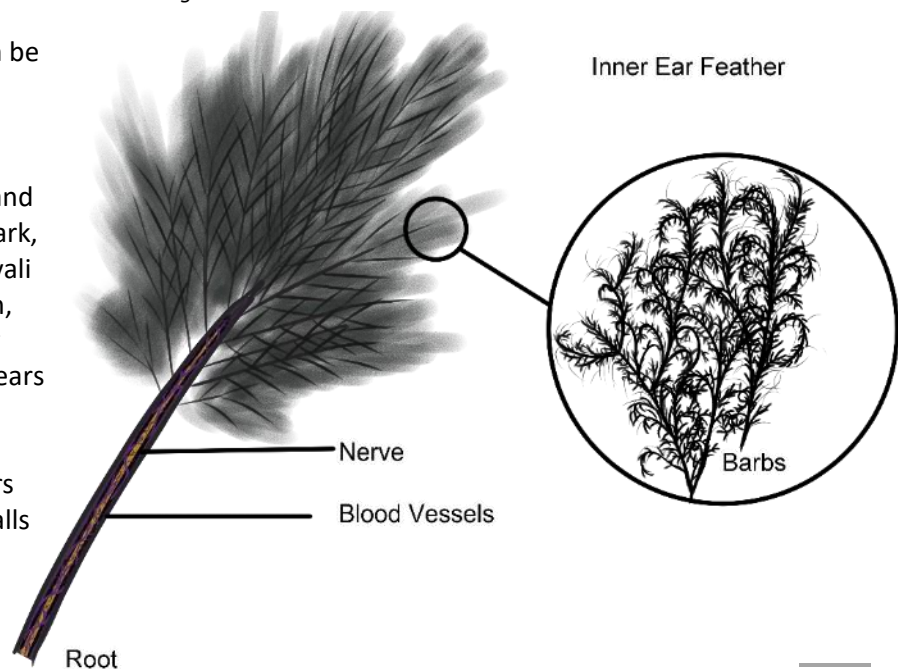

EMOTIONS

Expressions and body language for Avali are complex. The development of fine muscle movements on the head has allowed Avali to mimic expressions that are a tad like humans. Expressions like smiling, baring teeth, and frowning are a few examples of emotions that the face can express. The ears will move in conjunction with facial movements to help accentuate the emotions. The most important to expressing feelings is the production of sounds. Avali will produce a sound for nearly all emotions, as hearing is their primary sense. Avali will also adjust their body, wings, and feathers to express their feelings further. Certain emotions will cause them to flare their feathers, lean, adjust their legs, fan out their wings or tuck them in.

Sounds are by far an essential aspect of expression for Avali. A wide range of sounds is emitted, ranging from simple chirp-like sounds to cackling, snake-sounding hiss. For example, a high-pitched chirping sound will accompany happiness, pride, and joyful emotions. Anger, frustration, or scoffing are expressed by hissing through the secondary airway, with the sound of their tongue slightly cackling. In addition, baring teeth, flaring their tail, skirt, and chest feathers; and exhaling large amounts of air, "huffing," or inhaling their secondary lungs are signs of anger. Emotions such as contentment, love, flirting, and blushing is expressed with purring and cooing. These are also commonly accompanied by the feathers underneath the eyes flaring outward, a form of blushing. Clicking and casual chirping while idle and during periods of interest are also common.

SMELLING

Avali "smell" using their tongues, tasting the air similarly to Earth-bound snakes. It is common to see them tasting the air around them constantly. Avali do not possess a traditional nasal chamber for sensing particles. The sensing receptors are in the tops of their mouths.

The long, narrow olfactory bulb can be found at the bottom of the brain, along the topside roof of the mouth. Due to the lack of nasal passages, a secondary breath way for the Avali is not in the anterior of the head. Instead, it is located towards the back of the skull, between the ears, lining up with the pressure-regulating eustachian tubes. Watching the back of an Avali's head, you could see the feathers between the ears flutter during breathing.

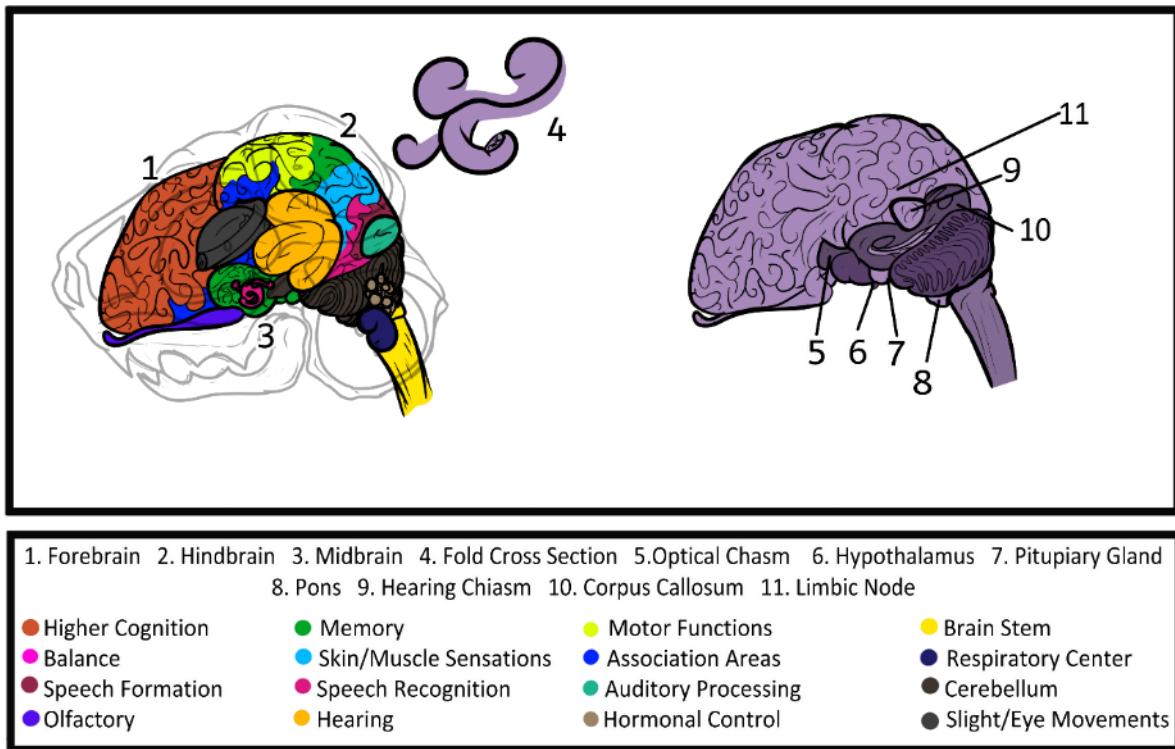

Figure 9 - Avali Brain ID Chart

BRAIN

The brain of the Avali is large and capable of complex thoughts and problem-solving. This ability has lent them to becoming great predators on their planet and develop into an advanced, space-faring civilization. Their brains are unique, containing four major regions. The brain consists of the rear hindbrain halves, the midbrain, and the large forebrain. The brain of the Avali extends down into the snout of the skull, where the presumed nasal cavity would be.

The forebrain of the Avali is quite noticeable, a monolithic section that protrudes from the center of the brain without any identifiable “halves.” This brain region contains what would be known as the hippocampus, higher cognition, association areas, and memory except for auditory memories. This is also home to the olfactory tract.

At the center of the brain is the midbrain. It contains the two sizeable auditory processing lobes, the hearing chiasm, light

processing receptors (photoreceptors), balance, orientation chiasm, coordinated response center, and hypothalamus. The midbrain also connects the hindbrain halves to the forebrain, and the cerebellum, spinal cord, and medulla oblongata.

The two hindbrain halves are located at the back of the brain and are distinguishable by appearing to have a seam going down the middle, essentially splitting them in half. This brain section controls evolutionary and fine muscle movements, auditory memory, skin and muscle sensations, speech recognition and formation, and further auditory processing.

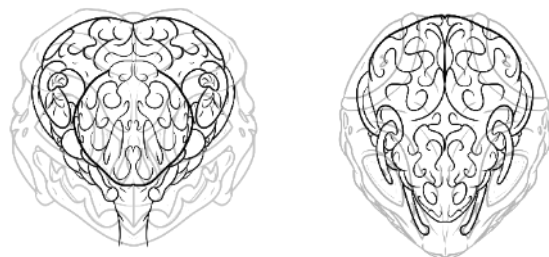

Figure 10 - Anterior and Top views of Avali Brain

SKELETAL STRUCTURE

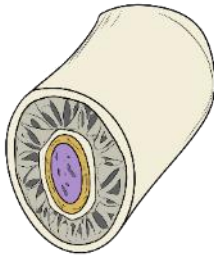

Figure 11 - Avali Bone Section

Avali evolved to have dense, partially hollow bones to handle the stresses of flight while not adding

unnecessary weight. The bones contain complex inner webbing to pass blood and provide structural rigidity. Unlike Terran birds, the bones do not allow the passage of air for breathing. Certain parts of the Avali, such as the large, primary feathers of the wings, and the tail, are supported by flexible but strong cartilage. The skeletons of Avali are silicon dioxide-based.

On the tip of the snout, a soft cartilage pad allows for sensing the temperatures of eggs and other items if needed. The cartilage also acts as a cushion for the tip of the head, as naturally, Avali cannot see that well. The "teeth" of the Avali are extended plates of the skull and mandible, grown into fine, razor-like points. A distinctive

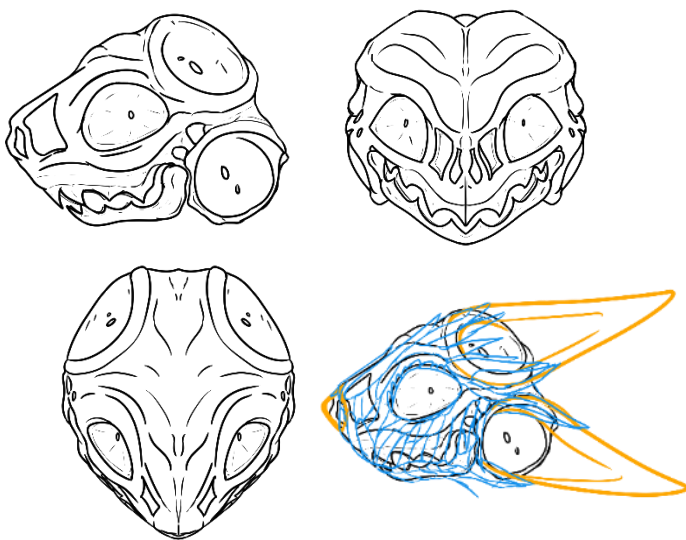

Figure 12 - Avali Skull (top), and muscle/Cartilage outlines (bottom)

characteristic of the center tooth is its "bucktooth" appearance, made possible by the center fuse point of the skull. The plates do regrow over time if damaged. The skull has identifiable ear orbits, in which the cartilage and muscles of the ear are attached to the head.

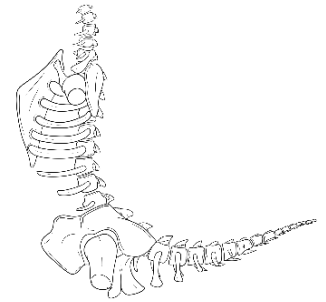

Figure 13 - Avali Torso Side

The chest has a large central sternum piece. The size allows for the strong wing muscles to be attached. The chest of the Avali protrudes outward, allowing for the expansion of the secondary lungs. The sternum has provisions that enable the upper rib cage to rest on and orbits for the anterior clavicles to attach.

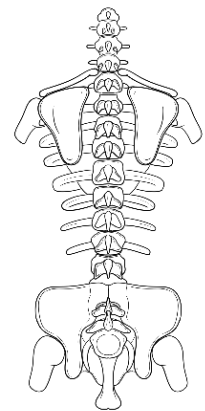
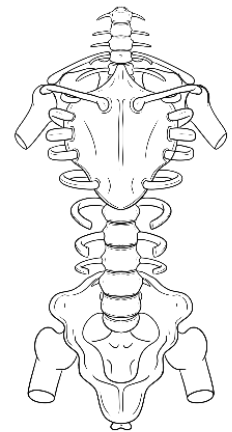

Figure 14 - Avali Torso Posterior (top) and Anterior (bottom)

The Avali hip bone is relatively large, allowing for egg passing and the attachment of tail muscles. The center part of the hip contains an ischium, which provides the attachment and stabilization of the tail.

Legs are set in a digitigrade design, possessing a three-piece main bone structure featuring two patella-type bones, aka "knee bones."



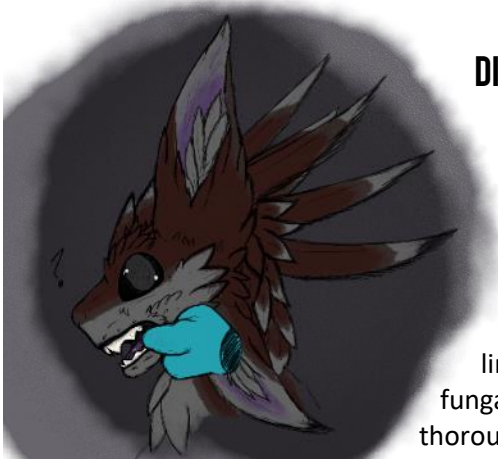

Figure 15 - Avali Maw Close up

DIGESTIVE TRACT

Hinted by their initial predatory looks, Avali are obligate carnivores. They can consume limited plant and fungal materials once thoroughly processed and

enriched. Meat and other animal products are preferred and can be digested without significant processing. Avali evolved to have a heavier, more complex digestive system, unlike birds. This complicated digestive tract has developed to aid in the digestion of multiple types of food and to mitigate a host of toxins found in their home world, Avalon.

The mouth of the Avali contains sharp, razor-like plates that allow for the ripping and crushing of food. The tongue can also taste the food that is being ingested. The salivating glands throughout the mouth douse the food in initial digestion enzymes and water/ammonia mixtures. Although not necessary in modern Avali society, the back of the throat contains five sharp cartilage spikes to prevent food from being lost during consumption. The spikes are

Figure 18 - Avali Stomachs

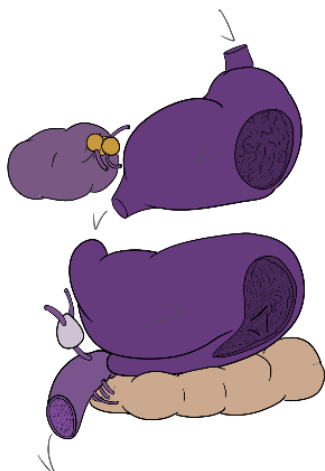

flexible to allow food to pass through. The top point also functions as the uvula, bringing the esophagus toward the pharynx. Along the sides of the throat and on the back are four additional adjacent spikes.

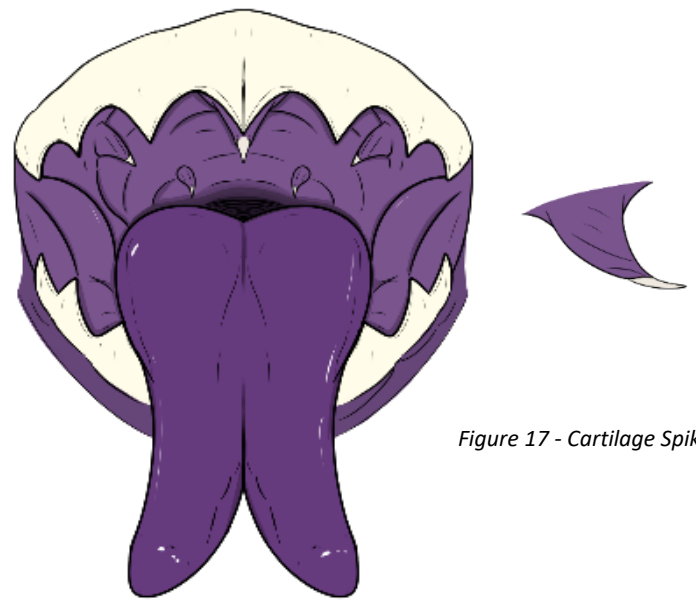

Figure 16 - Avali Maw

Figure 17 - Cartilage Spike

Avali have a pair of stomachs. One upper, though smaller, stomach for processing toxic chemicals from the local fauna and starting the initial breakdown of bone and cartilage materials. Food items are stored here for a short period, between 1-2 hours. The period allows enough time for the enzymes to begin entirely nullifying toxins in the food and softening the bone material. These enzymes are secreted in a pancreas-like organ attached to the left side of the stomach.

The lower, larger stomach is for the longer-term processing of food material, using enzymes and acids. This organ also contains small bladders for holding enzymes for digestion. Food often waits 2-4 hours, allowing for a full breakdown of the food before it moves into the intestines.

Once the food is pushed into the intestines, its doused in an acid-removing fluid before continuing. Towards the end of what would be the small intestine, food is held for a short time within a chamber. Attached to

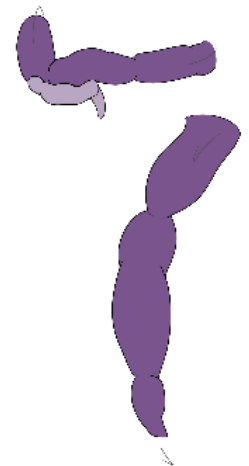

Figure 19 - Avali Intestines

this chamber is a large, appendix-like organ containing bacteria for coating unprocessable plant materials that could have been ingested. The process of absorbing water and ammonia begins. At the end of the large intestine, food will move into the rectum, which leads to the anus. Water and ammonia continue to be absorbed during this time.

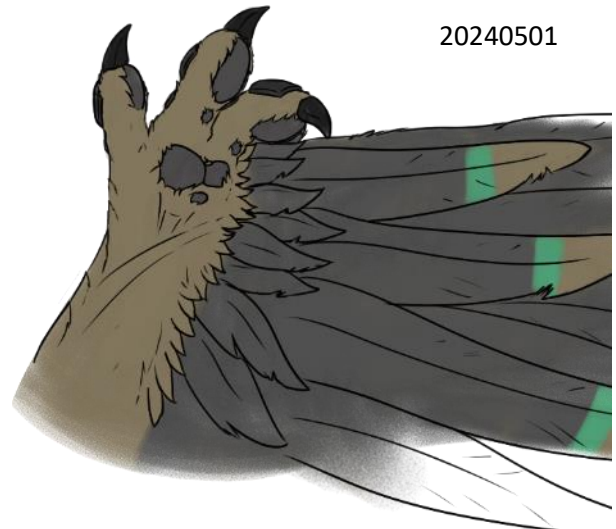

Figure 22 - Avali hand, showing paw pads (top), handprint (right)



hands have developed textured pads to allow grasping and holding onto items. Filoplume feathers surround the edges of the pad, offering a sense of feeling when using the fingers. Each finger is tipped with a sharp claw. The claw is attached with a strong tendon. From the hand, an opposable, long "finger" is used to manipulate the final extension of the wing. This finger has both phalanges fused. Due to the unique wing structure, the Avali mid-wing possesses an additional muscle that manipulates the forewing extension, often visible as crossing over and linking at the base of the hand.

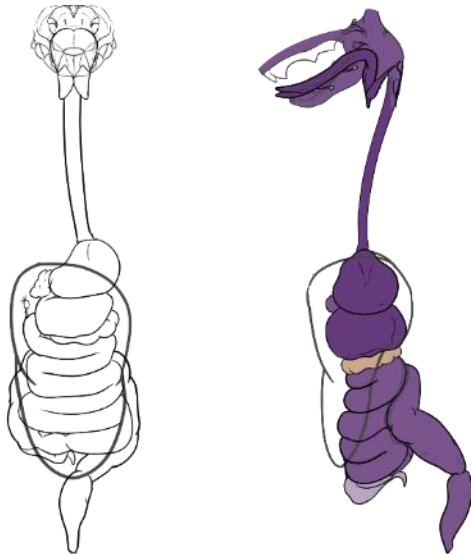

Figure 20 - Full Digestive Tract anterior (left), side (right)

WINGS AND HANDS

Commonly misconstrued as arms, Avali have two wings, with three smaller digits for manipulating objects and tools. Each digit contains two dexterous phalanges. They include two main fingers and an opposable thumb. The

Figure 21 - Wing Feathers, Paws, and Hands (left), Wing with feather roots and muscles (center), Wing bone and cartilage (right)

The wing's feathers begin at the upper to mid part of the chest and run entirely down the appendage, ending just at the outer base of the fingers. Some Avali also possess scutes on

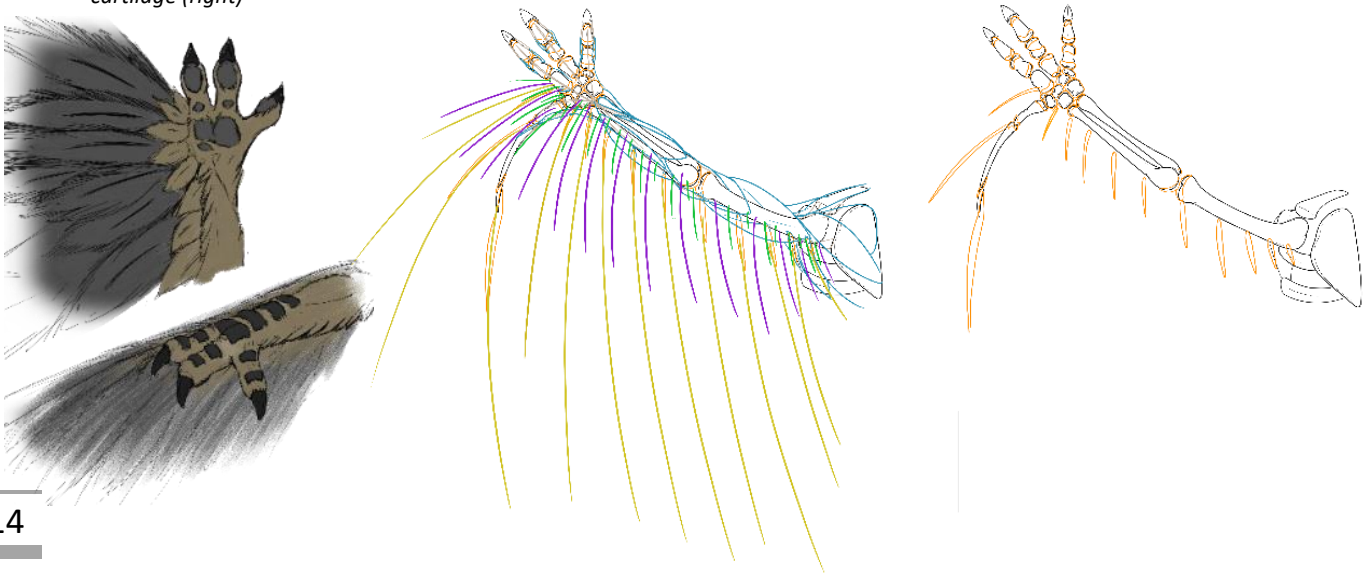



Figure 23 - Avali wingspan

their hands and fingers, a form of protection. The wings' feathers are layered, containing three regions of feather styles. The primary feathers are the large, easily seen contour feathers. These feathers are accompanied by a cartilage tip attached to the wing and extension finger for rigidity. Atop these feathers are the secondary feathers. These feathers are nearly half the size of the primaries; however, there are two secondary feathers to 1 primary feather. These feathers are more flexible compared to the primaries. Finally, the trinary feathers are a set of smaller feathers that run along the base of both the primary and secondary. These feathers are visible, though you can easily miss them. When not in use, Avali will fold in and tuck their wings.

feather tufts that run along the back of their lower calves and ankles, allowing additional protection against colder environments.

When moving, the Avali feet are splayed out flat on the ground. The talons help dig into the ground and foliage to aid in launching and running forward. When lifted, the toes retract inward when raised, forming a "V." Avali tracks are nearly single-lined, with the feet landing almost in front of the other during movement.

Avali legs are powerful. They have evolved to allow the Avali to jump and land with ease, critical for flying. When not flying, the legs allow the Avali to move with decent speed across their homeworld. Sprinting, leaping, and crouching, alongside basic walking, are all commonplace and within the capacity of an Avali. They also allow decent carrying capacity. Legs have been pivotal in the Avali's nomadic nature, which is critical to their survival.

Figure 25 - Avali Walking Example(top), Leg bone structures (bottom)

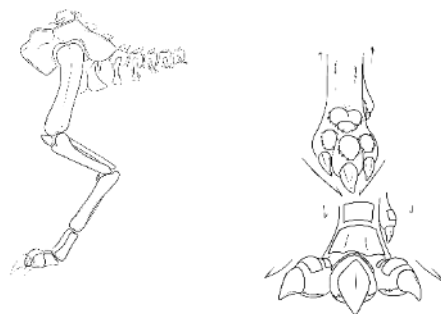
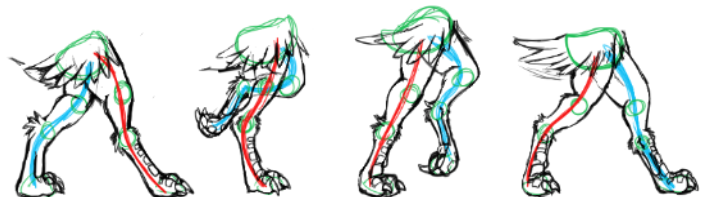

FEET



The feet of the Avali have evolved to have a good balance between ground mobility, climbing, and landing from a flight. Avali feet contain three digits and inner dewclaws, tipped with sharp talons for digging into the ground, foliage, and hunted animals. The base of their feet has thick pads for cushioning their ground navigation, protection, and landing. The tops and ankles of their feet also contain large scutes. Some variants of Avali have long

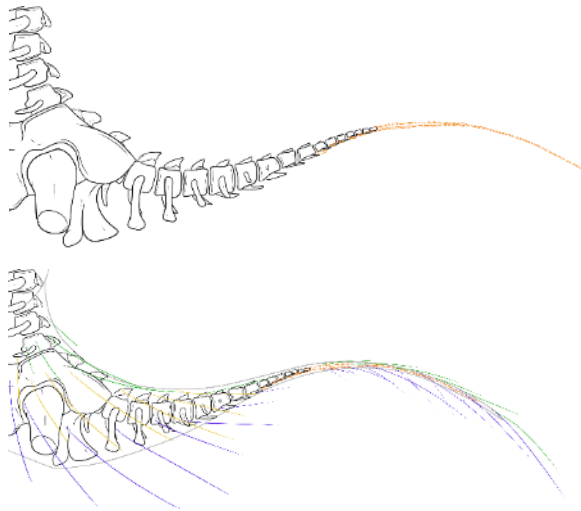

Figure 24 - Avali footpaw (top), footprint (bottom)

SKIRT AND TAILS

The "skirt" of the Avali is a series of primary and secondary feathers covering the hips and thighs and trailing off towards the end of the hip, ending at the base of the tail. Like the wing design, the feathers fall into three groups. The skirt's feathers aid with central lift and gliding during flight. Skirts are universal for all Avali.

Figure 26 - Tail and Skirt Bones (top), Feather roots (bottom)



The tails of the Avali are large, formed by a combination of cartilage and a series of feathers. When relaxed, the tail rests in a nearly straight, upward position. Tail designs can vary between each Avali, allowing for the quick identification of individual members. During flights, the tail splays out, adding more surface area to catch the air and creating drag for the Avali. While running, the tail acts as a counterbalance, allowing them to lean forward during runs and maintain speed.

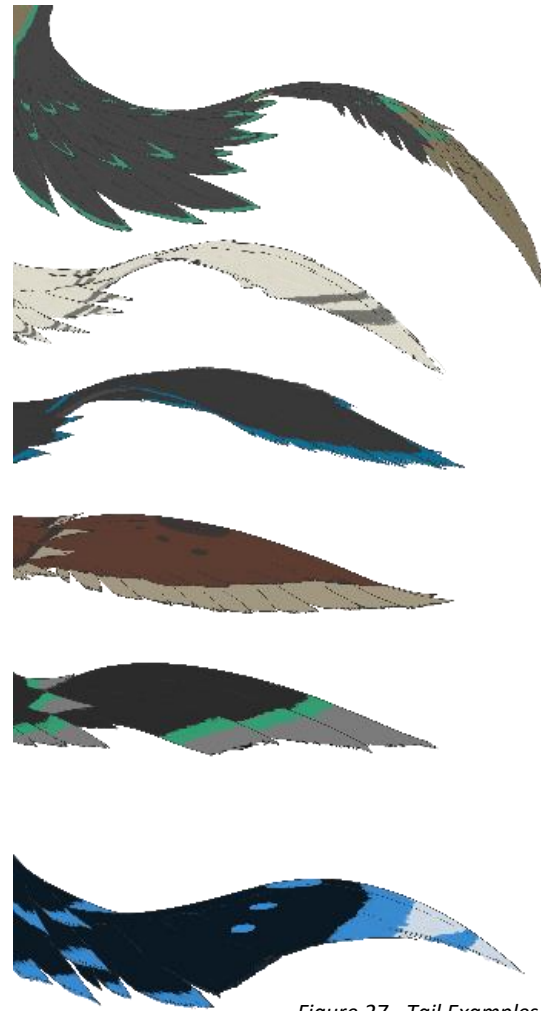

Figure 27 - Tail Examples

THE HOMEWORLD OF AVALON

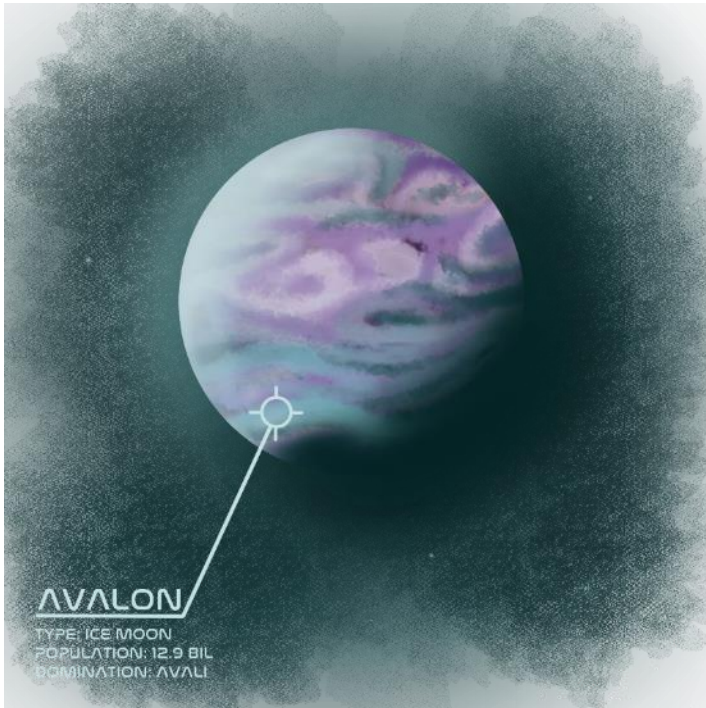

Figure 1 - Avalon

“Avalon would be a beautiful alien winter wonderland if it wasn’t for the overwhelming smell of ammonia” -United Nations of Earth (UNoE) Ambassador Josef Fuchs.

Located in an F8 Star system, also known as a “main sequence” star system and named Uresk, the Avali home world of Avalon is a large moon attached to a gas giant. The planet Elysium sits fourth in sequence, with six planets. As for Avalon, the moon is unique, with a dense atmosphere and houses a plethora of fauna, including the Avali. In comparison to Saturn's moon, Titan, also has a thick atmosphere and is the second largest moon in the Sol System, albeit having no confirmed life on the moon.

Avalon is roughly 75% the size of Earth, with a radius of 4784 km (2972.6 miles), compared to Earth’s 6378 km (3963 miles). Despite its size, the moon has 25% of the gravity of Earth, putting its gravitational pull range near 2.6 meters per second squared (m/s^2), or 8.5 feet per second (f/s^2), as opposed

to $9.8 m/s^2$ ($32.2 f/s^2$) for Earth. Its weaker gravity has played a considerable effect on the development of lifeforms on Avalon and gives it a very tall atmosphere, towering at nearly 210 km, or 130.48 miles. Its massive size pushes the moon far out from its planet, making it the 6th in a series of 8 moons, sitting near the rim of the giant’s ring. The moon sits at about a 26° tilt on its axis, giving it seasonal effects like on Earth. Additionally, Avalon has no dedicated micro-moon or asteroids.

Avalon is not tidally locked to Elysium and takes about 16 hours to complete a full revolution, making the days shorter than the ones on Earth. Furthermore, due to being hosted by a gas giant, the moon falls under complete darkness every 37 days due to the planet blocking out the star completely. This period lasts for three days before it returns to the starlight again. A complete rotation around the host planet is 40 days. Finally, for a complete orbit around the star Uresk, Avalon and its host planet take 440 days to complete a full year.

ATMOSPHERE

The atmosphere is a unique aspect of Avalon. Being a moon attached to a gas giant, nearly all other planets and moons within the system lack an atmosphere, or have a comparatively harsh atmosphere. The atmosphere can be broken down into six parts, like Earth’s, except for the lowest layer. The lowest layer is unique from the Earth, as heavier gases, water, and ammonia vapor clouds and fogs cover a sizable portion of the surface of Avalon, putting it in a near haze most of the year. In return to the thick, multilayered atmosphere and surface haze, very little of the Star’s light makes it to the planet’s surface. At the most, approximately 600 lux of starlight reaches the surface in the most ideal of conditions. In addition to the lack of light, the atmosphere causes the planet to remain reasonably cold, with temperatures ranging from $-105^\circ C$ ($-157^\circ F$) to $5^\circ C$ ($41^\circ F$).

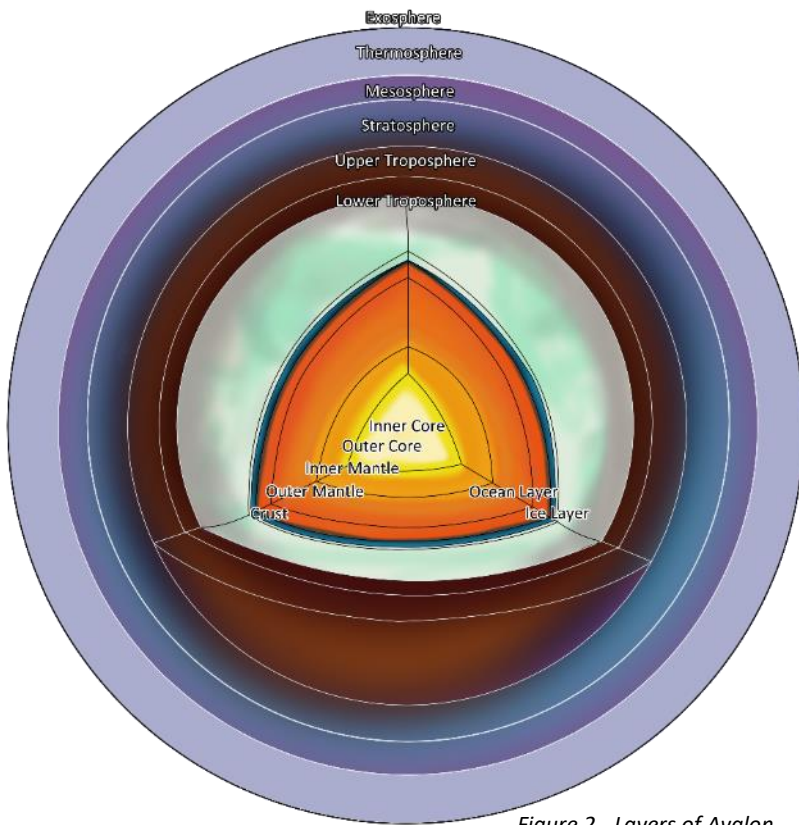

Figure 2 - Layers of Avalon

At nearly two times denser than Earth's (lowest point) and at least 1.7 times denser (highest point), an average human walking on the surface of Avalon would be equivalent to treading 15 meters (49.2 ft) underwater. The atmosphere's composition is mostly Nitrogen, at 72%, Oxygen, 21%, and a mixture of argon, methane, hydrogen, carbon dioxide, ozone, sulfur, ammonia, and other gases for the remaining 7%. Towards the lower parts of the atmosphere, the speed of sound travels at roughly 200 m/s (656.1 ft/s), slower than compared to Earth's. The topmost layers of the atmosphere give Avalon a violet-blue color, but with wisping, dense, whitish-orange clouds towards the moon's surface. The robust presence of Ammonia and water vapors, methane, and carbon dioxide are found closer to the planet's surface, creating a very cloudy appearance. The colors mostly seen on the surface of Avalon would range

from a deep reddish-orange to turquoise due to the atmosphere defusing much of the light coming in.

Being adjacent to a gas giant and active star, large amounts of radiation are emitted from space and are deflected across the atmosphere and gravitational field. During this, auroras can be seen littering the skies of Avalon. When Avalon is wholly eclipsed by its host planet, the atmosphere facing the world will glow like an Aurora. During favorable conditions on the surface of Avalon, the Avali can enjoy the beauty of the auroras. Thanks to its position within the rings of a gas giant, Avalon also experiences frequent meteor showers due to the debris of the rings hitting the moon's atmosphere.

SURFACE

From space, an onlooker would have a challenging time trying to identify the surface of Avalon. The dense clouds cover much of the planet. The moon's surface is quite cold, though it holds many diverse biomes and bodies of both ammonia and water. The tidal seasons on

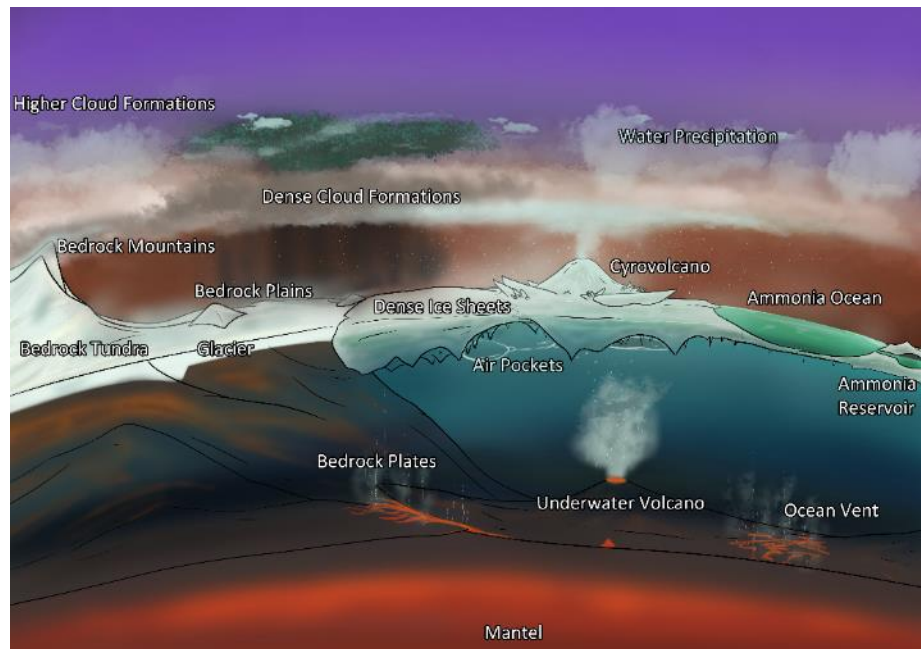

Figure 3 - Surface Layer Breakdown of Avalon



Figure 4 - Small Pack of Avali treading through an ocean of ammonia, along an ice sheet crack

the moon are dictated by its positioning of it to adjust to the host planet and by the neighboring moons.

Avalon biomes are vast and consist of different forests, mountains, ice sheets, marshes, grass-like plains, and extremely cold areas where habitation is near nonexistent. Each has unique animals and flora, thanks to the alien nature of the planet. Additionally, Avalon is seismically active, with moving ice sheets and rock plates and being cryovolcanic, contributing to the dense atmosphere. Avali cities and settlements are usually built away from seismically active areas.

Avalon houses a variety of megafauna, ranging from trees to large, ocean treading creatures the size of small islands. The low gravity on the moon has given the ability of megafauna like these to thrive. However, the entirety of the planet is not home to just large, towering creatures. Smaller creatures, such as

Avali, have also evolved and thrived. Due to the planet's cold temperatures, most animals are small, not using much energy.

Underneath a large portion of the planet's surface, a deep active ocean absorbs most of the planet's core heat. This heat, in return, creates surface cryovolcanoes, erupting water, ammonia, and other debris onto the surface and forming new ice sheets. The undergrowth and creatures of Avalon can be as complex as the surface biomes. Both above and below-ground biomes feed into sustaining life.

Liquid ammonia is extremely common and forms modest oceans, rivers, ponds, and lakes in some low-lying areas. The liquid ammonia also creates cold bogs, swamps, and marshes, accompanied by thick fogs and hospitable fauna. Ammonia rivers quickly cut through water-based ice, creating gorges and underground rivers and ponds. This also has the

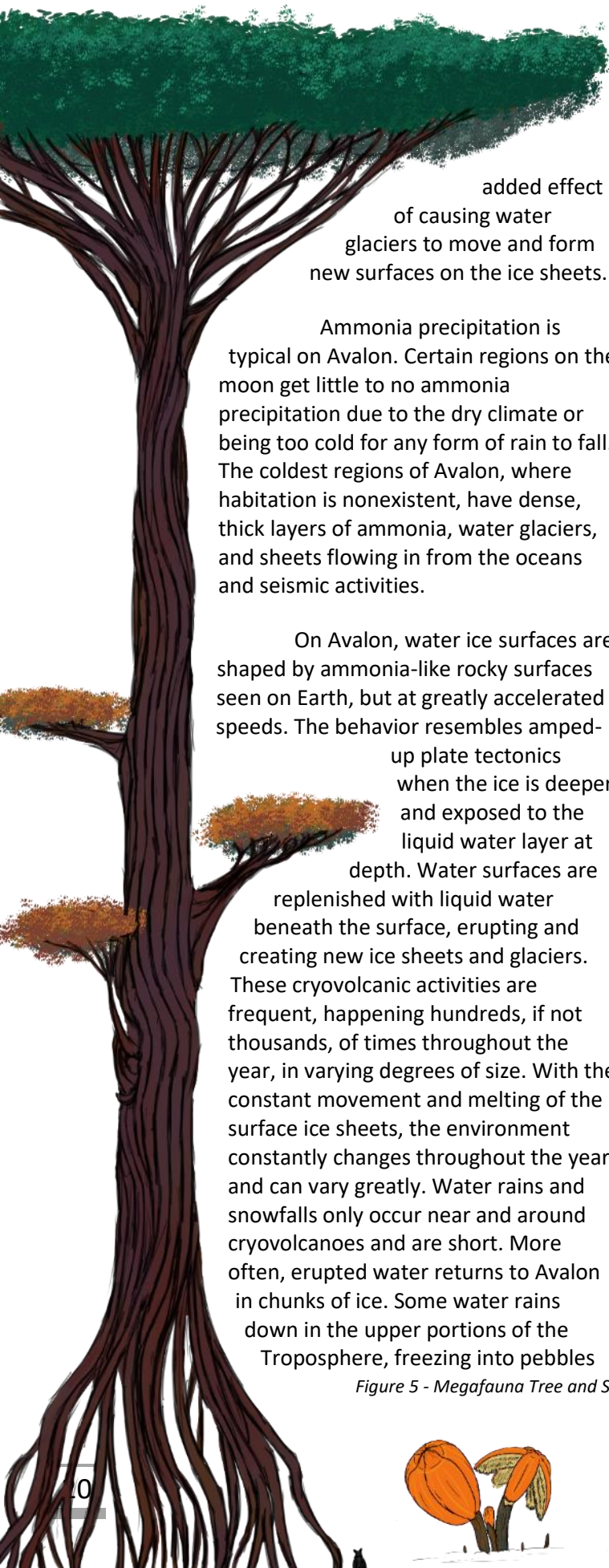

added effect of causing water glaciers to move and form new surfaces on the ice sheets.

Ammonia precipitation is typical on Avalon. Certain regions on the moon get little to no ammonia precipitation due to the dry climate or being too cold for any form of rain to fall. The coldest regions of Avalon, where habitation is nonexistent, have dense, thick layers of ammonia, water glaciers, and sheets flowing in from the oceans and seismic activities.

On Avalon, water ice surfaces are shaped by ammonia-like rocky surfaces seen on Earth, but at greatly accelerated speeds. The behavior resembles amped-up plate tectonics when the ice is deeper and exposed to the liquid water layer at depth. Water surfaces are replenished with liquid water beneath the surface, erupting and creating new ice sheets and glaciers. These cryovolcanic activities are frequent, happening hundreds, if not thousands, of times throughout the year, in varying degrees of size. With the constant movement and melting of the surface ice sheets, the environment constantly changes throughout the year and can vary greatly. Water rains and snowfalls only occur near and around cryovolcanoes and are short. More often, erupted water returns to Avalon in chunks of ice. Some water rains down in the upper portions of the Troposphere, freezing into pebbles

once passing the clouds.

BIOMES

As mentioned previously, Avalon is home to a wide variety of above and below-surface biomes, which are critical to sustaining the ecosystem on the moon. Various plants, animals, and fungi have adapted to the unique characteristics of Avalon. While what may seem inhospitable to humans, these organisms have learned to evolve and thrive. Here are a few examples of the biomes and unique characteristics found on Avalon.

Along the warmer parts of Avalon, rain-forest like areas are home to giant trees that tower upwards above the first layers of the atmosphere, gathering precious starlight. Below the canopies of these trees, long strings of plants and fungi grow along the trees and branch offshoots. Various small and medium-sized animals feed off the flora and each other. The ground level is covered in slimy fungus and low-level plants, covering a marshy ground. The roots of the trees extend above the surface, lifting the trees higher in the world, and sink deep into the ground, reaching the underwater reservoirs.

Bioluminescent fungus is a common sight on Avalon. The fungus feeds from the neighboring plants, decomposing animals, and underground life. The chemical reaction from the fungus feeding causes certain buds, pods, or stems to glow a turquoise, orange, or soft yellow color. This luminescence gives nearby

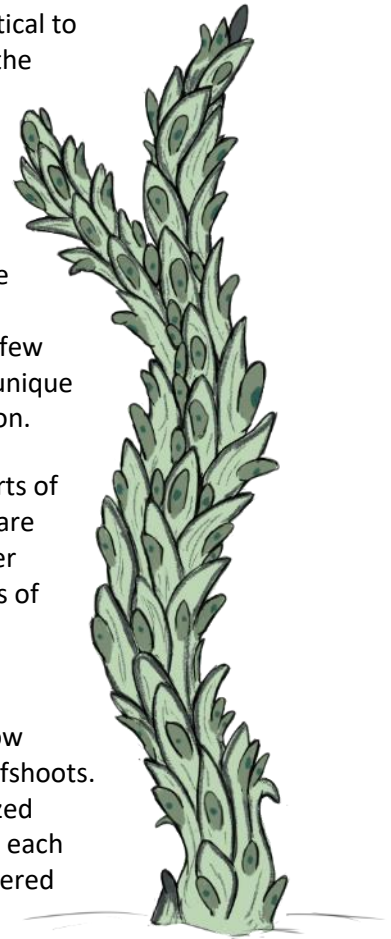

Figure 5 - Megafauna Tree and Samples of Plant and Fungal organisms



plants a weak but sustainable source of energy.

Scattered across fields and caves, tall crystalline ammonia structures grow, formed by the cold weather and rainfalls. The crystals vary in color and opacity, with some able to amplify the light given off by this fauna, illuminating the surrounding area with light. Certain crystals have naturally glowing chemicals and bacteria trapped inside. These crystals can be harvested and used as light sources. Other crystals emit heat, with certain chemicals reacting within and creating a harvestable heat source.



Figure 6 - Crystalline Structures

Surface stone mountain ranges are rare but present across Avalon. Mountains like these are the peaks of the lower bedrock crust. Most stone mountains are found in underground oceans but cannot reach the moon's surface. Surface ranges are eroded and formed by ammonia rains, giving them a resemblance in shape to terrestrial mountains, though amplified in slope due to lower gravity. Where

rocky bedrock undercuts the normal surface or is present in large flat areas, you encounter ice deserts made up of grains of water ice similar in shape and



Figure 7 - Glowing Fungi, "Fyrray Thak"

structure to sand.

Forests of trees, both fungi and regular, are scattered across the surface of Avalon.

Some can be found on fertile ice sheets, slowly floating across the oceans. Fungi trees are large, dense-looking structures, some with large identifiable pods, while others can be seen with long vines, oozing substances that contain spores onto the surrounding areas. These trees are known to sprout even in the most hostile locations, with



Figure 8 - Fungi Cluster

specific "clusters" of trees floating in oceans. While fungi trees are generally thicker and clustered together, regular trees are slender and have a spike-like appearance. Some variants have small leaves protruding out the sides of these trees. These are commonly found in bedrock areas of Avalon, though not unheard of to be seen on other parts as well. Nearly all plants and fungi life on Avalon sprout spore-like seeds, either dropping from pods or the tops of the organisms.

Under the surface, a vibrant undergrowth can be found. Deep roots of trees, fungi, and animals adapted to the darkness and constant wet nature can thrive in these areas. The most common sights here are caverns, tunnels, and seemingly endless oceans. Even with ice sheets continuously melting and forming, starlight never reaches these biomes outside the

bioluminescent fungi and some creatures. The environment is generally warmer in this part of Avalon due to the warmer oceans and closer proximity to the planet's core. Turbulent water and ammonia states constantly keep pressure against the ice sheets, waiting to erupt onto the surface. The creatures that habit this Avalon



Figure 9 - Blood Sucking Fungal Organism, "Burrk Thakrus'ska"

part are rarely seen above the surface. The adaptation to warmer and darker environments prevents them from surviving effectively.

CREATURES



Figure 10 - Longhaired Bovine-like Creature, "Skskcee'gehkja"

immense in their size and evolved this way thanks to the lower gravity found on the moon. Thankfully for Avali, this allows them to have ample selection for hunting.

Megafauna on Avalon are uncommon and only found in certain areas of the moon. Most of them are in the oceans, while others slowly meander across tundra landscapes and deserts in search of food. Some animals float on the seas, their backs becoming moving islands covered with plant and fungal life. Underneath the surface, large fish and lizard-like animals have grown and occupied the oceans, making those oceans treacherous for those unprepared.

On the surface of Avalon, small and rapid breeding animals are scampering across the growths of fungi and planets.

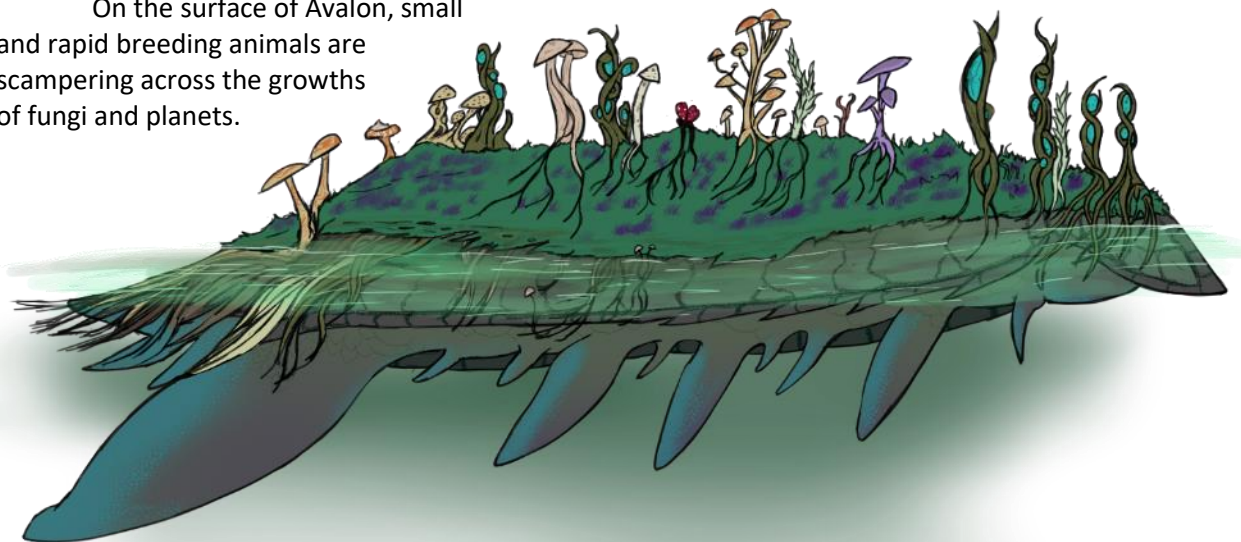

Figure 13 - Megafauna Turtle-like creature, it's shell housing a small island ecosystem, "Chrgakbz GehrR'rwkkr Ku'gRrmay"

Most of these small animals are herbivores, feeding on the leaves, fruits, and pods of fungi. These creatures have unique appearances, combining some traits of lizards and mammals and having feathers for protection. Most of them barely break 40 cm (15.7 in) in length, with even some of the smallest only being 6-8 cm (2.4-3.1 in) long. A common trait amongst all these small animals is their tendency to have large litter or clusters of eggs.



Figure 11 - Small Rodent-like Creature, "Skacik kjrrk'bwcak"

In the skies, lizards and bird-like animals have adapted to fly in the dense atmosphere outside our Avali friends. Some giant flying lizards resemble some Pterosaurs found on Earth, able to soar high above the thick cloud

Figure 12 - Orange Tipped Catalina, "Ahrwa Caklerah"



formations covering Avalon’s surface. Smaller bird-like creatures can be seen filling the skies, some only coming out during dark periods to feed on other animals or fruits.

MOON COMPOSITION

As already discussed, the surface of Avalon is split into three distinct layers: the icy cover, oceanic undersurface, and the bedrock crust. Further beneath lies a composition like Earth’s: a molten mantle circulating melted rock and metals erupting into the under oceans and active nickel-iron core, though smaller than Earth’s core.

The crust of Avalon is composed mainly of stones of various forms and deposits of metals and minerals. Across the peaks and below the oceanic surface, large deposits of copper, iron, tungsten, magnesium, lead, and cobalt can be found easily. These comprise a large variety of mines located on Avalon.

While dense with minerals and metals, the crust of Avalon is reasonably thin, with few tectonic plates colliding and creating mountain regions. Few of these regions have active volcanic activities, though lava flutes and vents can be found within mountain cave systems. The moon is covered with a deep-water ocean, constituting nearly 85% of the surface mass.

Going below the crust, the mantle of Avalon is composed of the expected molten rock and metals. Constantly churning, the blanket occasionally erupts into the oceans, keeping them equally as active. With the relatively thin crust, at approximately 3 km thick at its lowest points, the mantle can constantly move the crust, creating unique plates and constant seismic activity.

The core of Avalon is dense and comprises of molten nickel and iron. It is actively spinning, creating a strong enough magnetic field to protect it from solar winds and strikes. Although smaller than Earth’s core, it is still critical to the survival of the moon. The core can maintain its constant heat thanks to a phenomenon known as “Tidal Heating.” With tidal heating, the moon is constantly stretched by its host planet and surrounding moons. This causes immense friction within the moon, allowing the core to remain hot and active. The moon’s mass creates a gravitational pull to sustain an atmosphere and life.

Figure 14 - A Blue-furred Glowing Lizard-like Creature, “Eepuor’Brk”

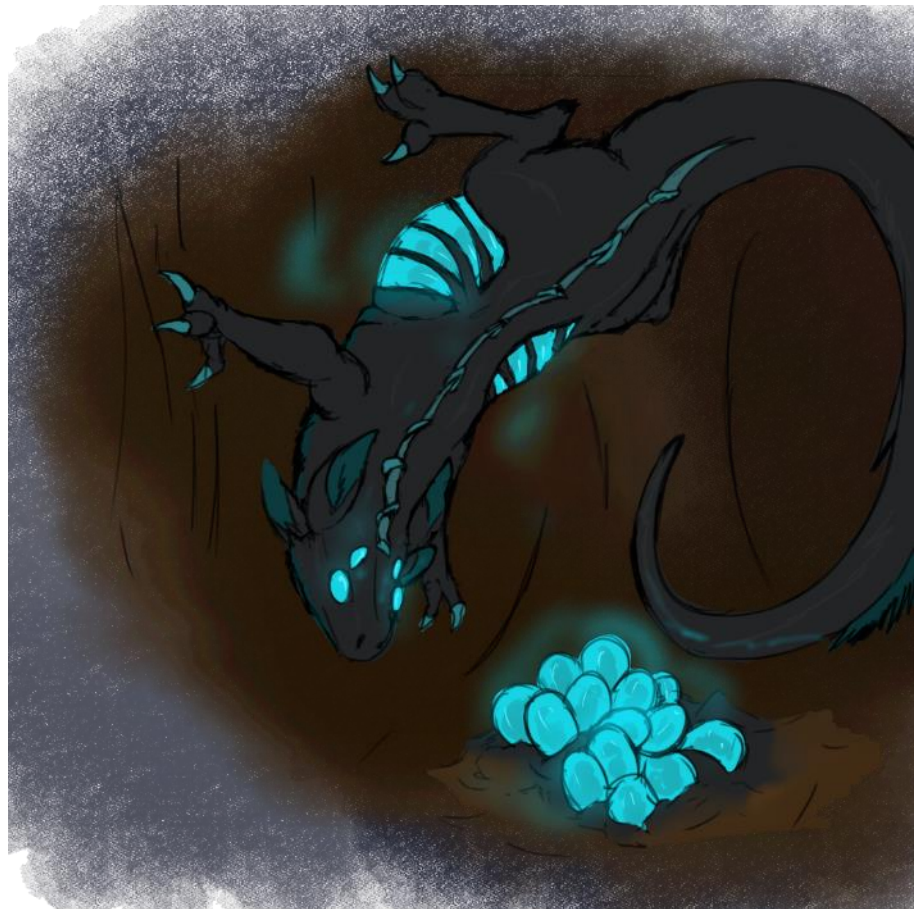

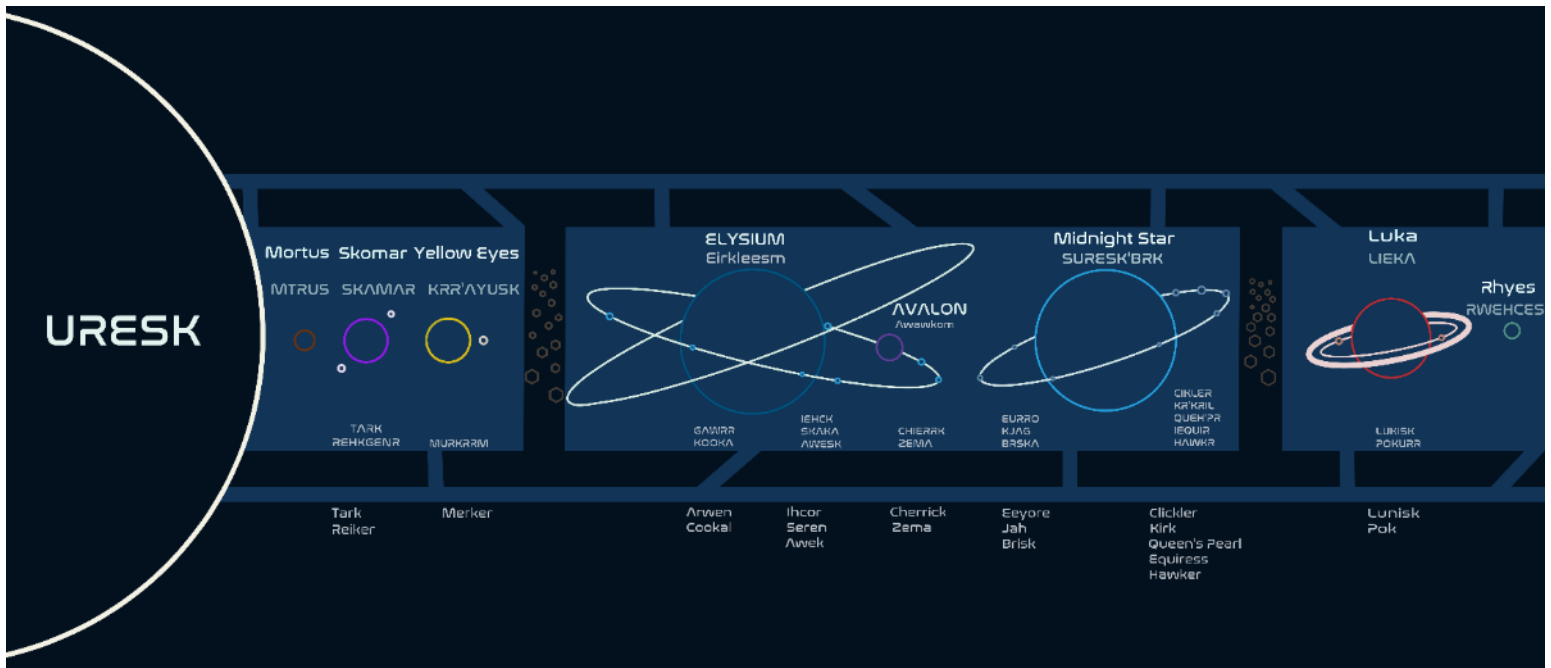

Figure 1 - Simplified Uresk System Map

THE URESK STAR SYSTEM

The Uresk star system is a series of 7 planets and two asteroid belts. Out of the seven planets, 5 have moons that orbit around them. Avalon, a moon of Elysium, sits in an ideal habitat zone known as the “Goldilocks” zone. Furthermore, the gas planet’s presence also protects from the active star’s radiation and oncoming debris that can impact Avalon. For simplicity, all names have been translated into something more easily understood to humans.

URESK

One of the oldest names in the Avali language, Uresk (Uhr’esk), is the name of the F8 main sequence star at the system’s center. Uresk is much more potent than Sol, burning at a staggering 6100 Kelvin (5827°C or 10520°F) and shining at 1.78 times brighter. The star also emits much more ultraviolet (UV) light than Sol. While the exact age is unknown, most Avalon scientists put Uresk around 650-700 million years old.

MORTUS (MTRUS)

Located closest to Uresk is a small planet known as Mortus. About half the size of

Avalon, Mortus is a planet with no moons or unique atmosphere. The surface of Mortus is entirely uninhabitable. Being so close to the star, Mortus’ surface is constantly blasted with extreme heat and radiation. Due to this, the surface is scorched brown with some notable streaks of bleached peaks. The planet is the fastest to orbit around the Uresk, taking only 155 days to complete a full revolution around the star.

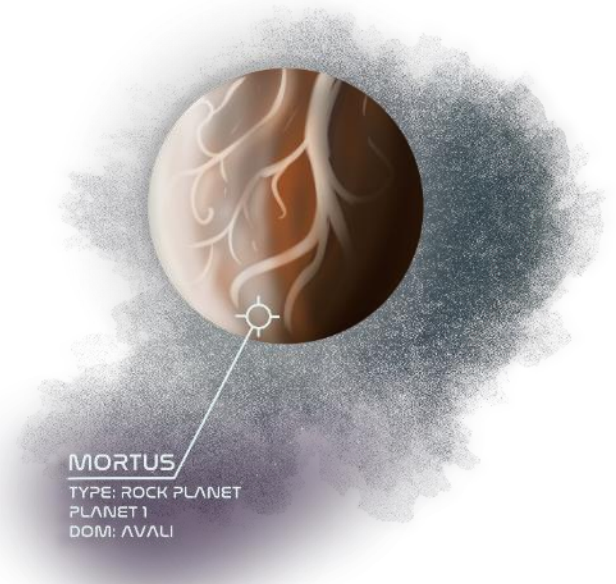

Figure 2 - Mortus



Figure 3 - Skomar and Moons Tark (top) and Reiker (bottom)

SKOMAR (SKAMAR)

Second in the line of planets, nearly the same size as Earth, is Skomar. Glowing a beautiful pinkish purple, Skomar's atmosphere glows when aligned with the star. Despite its beauty, the atmosphere is entirely toxic, containing large amounts of Neon, Helium, Xenon, and Radon. The surface of Skomar is also highly radioactive. Despite this, the planet's beauty puts one in awe.

Skomar has two small moons that orbit it. Each moon is always perpendicular to the other. The moons, known as Tark (Tark) and Reiker (Rehkgendr [Rehk'g-ner]), reflect some of the glow from Skomar, giving them a faint pink tone to their bleached surface. Both moons are riddled with asteroid and meteorite impacts, giving them a very lumpy surface appearance.

YELLOW EYES (KRR'AYUSK)

Translated from Krr' Ayusk (Kerr~-ayusk), the "Yellow Eyes" is a yellow planet that sits third in the line-up. Roughly the same size but with a thinner atmosphere than Skomar, Yellow

Eyes looks a sickly yellow color due to the heavy sulfur dioxide atmosphere. The name comes from ancient tales of a yellow eye peering down onto Avalon. Yellow eyes is one of a few planets that can be viewed from the surface of Avalon, given the right conditions. Though the modern Avali knows better, they kept the name for tradition's sake. The surface of Yellow Eyes is quite volcanic, contributing to the sulfur dioxide presence. While the activity on the planet has slowed since its discovery, it remains active and scorching. The planet's surface is a rusty orange due to the significant presence of iron and copper. Lakes of sulfur can be seen scattered across the surface, consisting of sulfur, salt, and even molten copper.

Yellow Eyes contains a singular moon, Merker (Murkrmm [mur'kr~m]), which makes it unique. Yellow Eyes is the only planet in the system with just one moon. Merker is relatively unremarkable and equally as bleached as the moons of Skomar, with faint specks of copper. However, large amounts of sulfur and copper have been found on Merker, giving way to theories of Yellow Eyes once being two planets that collided with each other, leaving one planet and a moon.

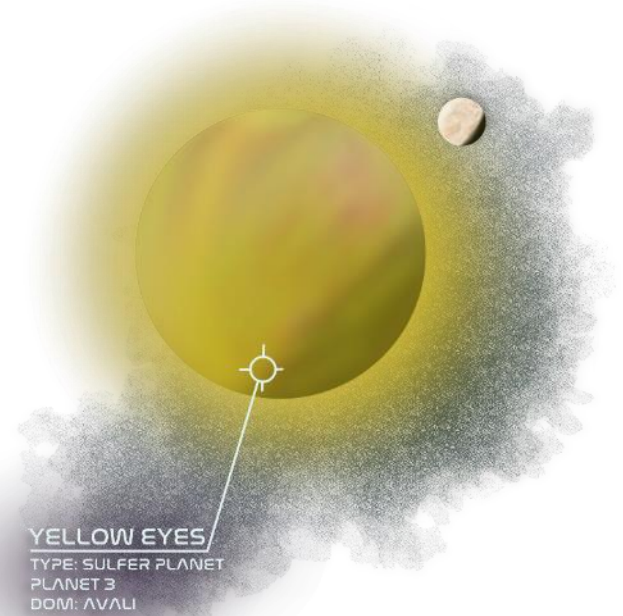

Figure 4 - Yellow Eyes and Moon Merker



MIDNIGHT STAR
 TYPE: GAS GIANT
 PLANET 5
 DOM: AVALI

Figure 6 - Midnight Star and Moons (left to right) Eyor, Jah, Brisk, Clickler, Queen's Pearl, Equiress, Hawker, and Kirk.

and xenon. Unlike Elysium, Midnight star contains one ring, a faint halo composed mainly of ice and dust.

Within the ring of Midnight Star are eight total ice moons, two of which have a unique appearance. The names of these moons are Eyor (Euro [Eu'rr~o]), Jah (Kjag [kj-kagrkk]), Brisk (Brska [Br'ska]), Clickler (Cikler [Clik-lyr]), Queen's Pearl (Queh Pr [queh'prr~]), Kirk (Kr'Kril [KRr~-Kreel]), Equiress (Iequir [Ee'quirR~]), and Hawker (Hawkr [Hah-kur]). While most are composed of various types of ice, Kirk and Queen's Pearl are unique in having a deep white, cloudy appearance. However, the surface of these moons are extremely cold. While no life forms have been detected on these moons, their atmospheres are unique.

LUKA (LIEKA)

Luka's is the sixth planet in the system and sits just past the outer asteroid belt. Luka is the third gas planet. It is bright red with a thick white and orange ring set surrounding it. Luka is also shrouded within a rocky cloud. Its fiery red appearance is quite jolting compared to the previous planets before it.

Although smaller than the last two gas planets, Luka has a very dense center of mass and, consequently, a high gravitational pull, capturing large amounts of debris from the space around it. This has caused the formation of large, thick rings around Luka, which comprise of asteroids and meteors primarily.

Luka has only two notable moons within its rings, Lunisk (Lukisk [Loo'kesk]) and Pok (Pokurr [Puo'kurr~]). Due to being subject to Luka's gravity, the moons are constantly pebbled with oncoming asteroids and other space debris, making them rich in resources but very dangerous to navigate. For a long time, most scientists on Avalon could not identify any moons near Luka due to the density of the rings around it.

Figure 7 - Luka and Moons Lunisk (left) and Pok (right)

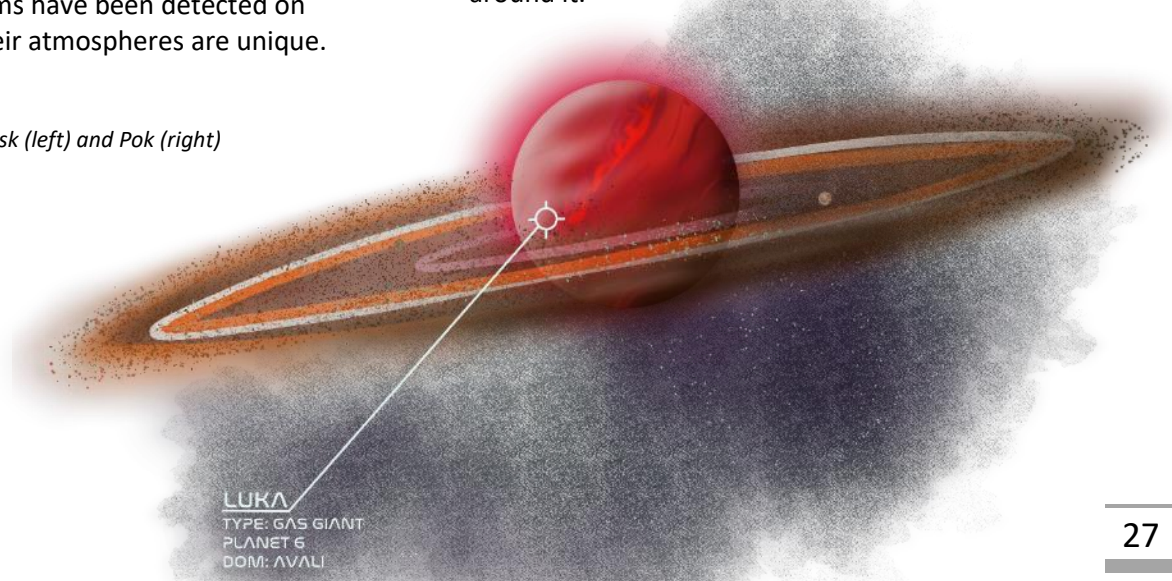

LUKA
 TYPE: GAS GIANT
 PLANET 6
 DOM: AVALI

RHYES (RWEHCES)

The last planet in the Uresk system is Rhyes. Rhyes is slightly bigger than Avalon, though it contains a frigid atmosphere and is even darker than Avalon. The slow-moving atmosphere and distance from the star give Rhyes a nearly black center appearance, with its dense green sky completely covering the surface. Rhyes has no moon that orbits it. The lonely planet is constantly in the shadow of Luka, though not locked to the planet.



Figure 8 - Rhyes

CHAPTER SUMMARY

RyuuujinZERO conceived the Avali race and concepts. This lore book takes those core concepts and further evolves them into a more substantial product. While this book closely follows those base concepts, it is not certified as official lore.

The Avali are an alien race that resembles the Cretaceous era Deinonychus most closely. The race is fully feathered, wielding dual sets of hypersensitive ears, sharp claws, and plate teeth. They are obligate carnivores and feed on the animals around them. Their large and complex brain structures allow them to develop tools and complex languages and calculate complex problems. The species is exclusively pack based, relying on each other to survive.

The Avali homeworld, known as Avalon, houses many species and ecosystems. These systems include the deep, dark under-oceans, the surface life on ice sheets, and large megafauna creatures and flora that populate the moon. The dense atmosphere towers high above the world, preventing much of the light from the nearby star from reaching the surface. As such, the surface of Avalon becomes dimly lit or is entirely devoid of light.

Life on the planet has evolved to these harsh conditions. The world provides little stable ground to develop on. The bedrock areas of Avalon, which are the only regions not entirely dominated by ice, have been exploited by all life for survival. The ice shelves' constant shifting changes Avalon's landscape each year, forcing most to remain on the move.

The Uresk star is an F8 class main-sequence star, giving off much more ultraviolet light than the Sun. The star's young age can be seen through the density of debris that orbits it.

The Uresk star system houses seven planets, with an inner and outer asteroid belt. Each planet that orbits the star has unique characteristics, setting each apart. The most remarkable of these planets is Elysium, the host planet for the moon Avalon and easily distinguishable with its dual dense rings.

In the next chapter, we will begin the breakdown and analysis of the Avalian culture, the development of societies and governments, their technologies, and how Avali conduct themselves through day-to-day activities. Each section will review certain aspects more than others. In addition, the introduction of the Avalian Core language and diplomacies will also be discussed.

AVALIAN CULTURE

CHAPTER 2

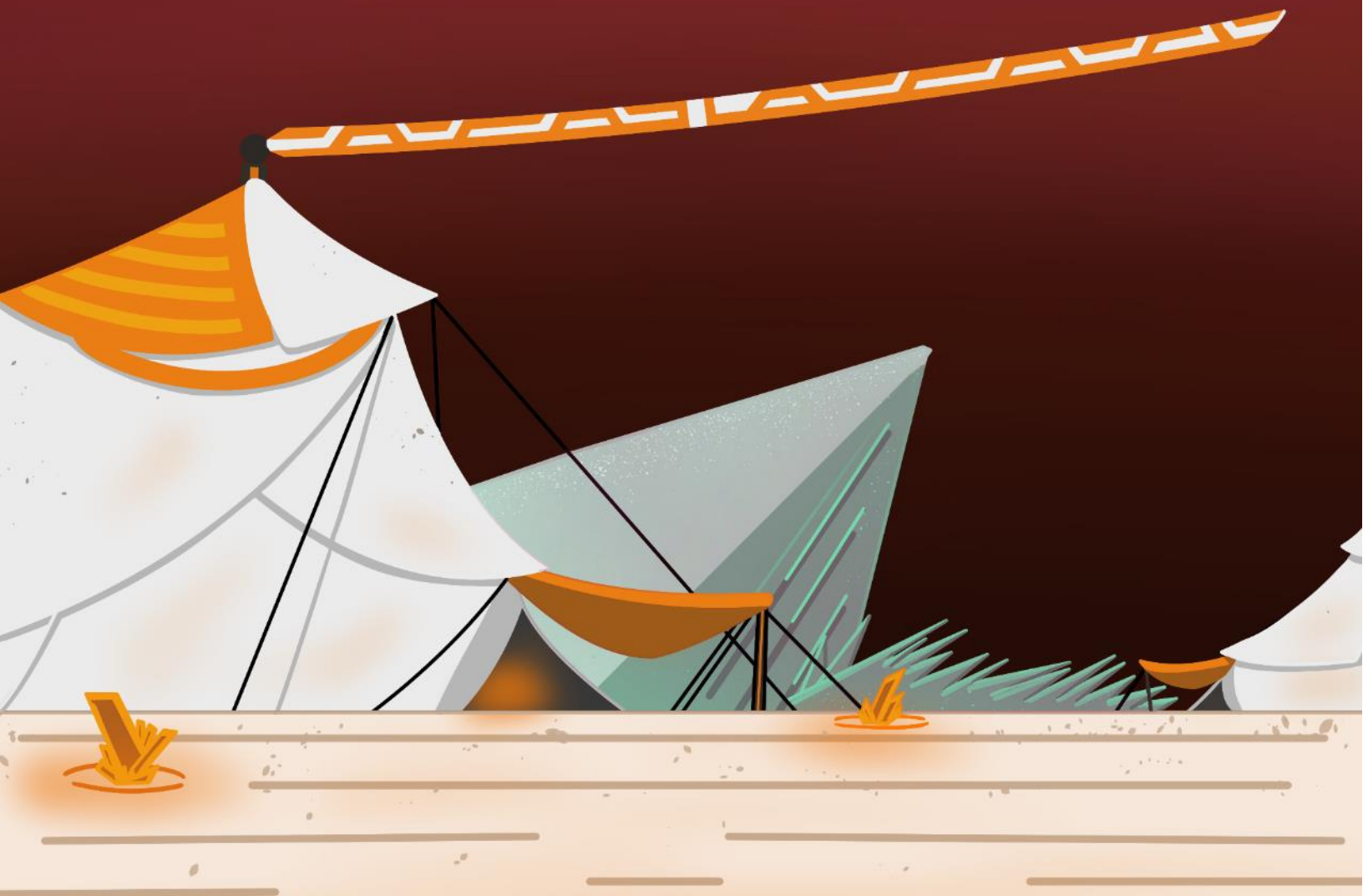

STRENGTH THROUGH UNITY

Like human cultures, Avalian cultures can be complicated and unique depending on the development area. A common theme amongst all cultures of Avalon is the focus on pack unity. Avali and their societies and cultures developed differently from humans in many ways. Their very migrant lifestyle and interesting environment evolved a foreign way of thinking and acting. Throughout this chapter, Ryuujin’s questions, “What if we had an alien race that was highly pack centric to the point of co-process information and had lower self-cognition?”, “What if they relied more on hearing than eyesight and had low-temperature biology?”, “How would they interpret the world?”, “What differences might they have in

developing tech?” and “How would they view regular aliens?”

Each section will discuss the critical aspects of each of these questions. They will also take the original concepts developed by Ryuujin and expand further upon them. Due to cultures ranging from niche to all-encompassing, only significant aspects will be touched upon. Only major historical events that caused such a substantial shift in Avalian culture will be presented. Specific ideas and concepts within this chapter will also answer underlying questions about Avalian culture that become present when discussing culture. Examples such as food supply and languages are answered.



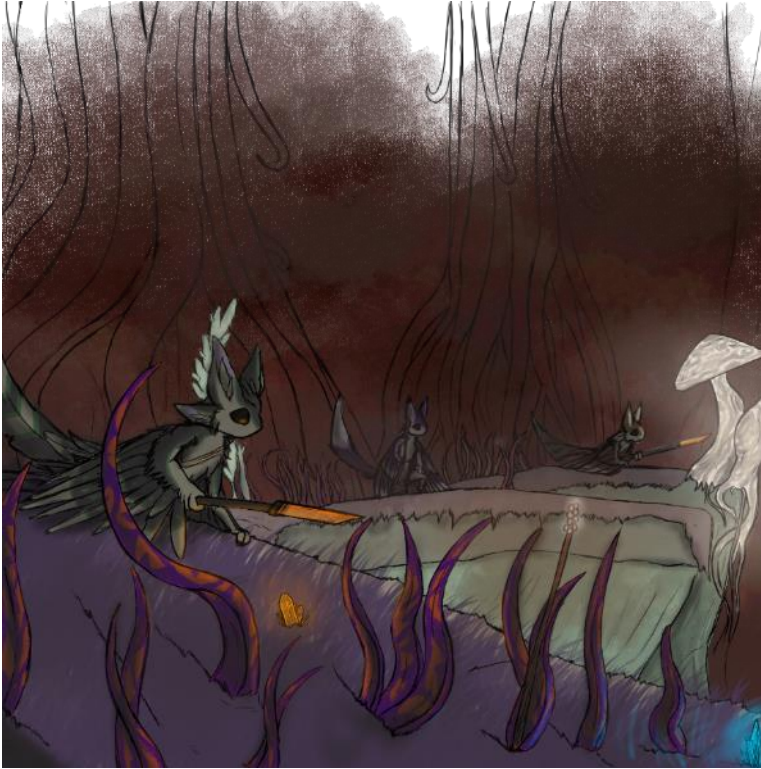

Figure 1 - Pack of Avali Hunters

HISTORY OF AVALIAN SOCIETIES

"Avali, despite their carnivorous and predatory nature, have a rich culture. Their unity in each other is something other races would aspire to reach." -Dr. Zihan Li, Galactic Historian

With an alien race comes an alien culture that was slow to develop. Avali, at their core, are pack hunters and, thanks to the ever-changing environment of Avalon, are nomadic. Tribes of Avali hold their traditions, values, and methods of life, but all share a central theme of pack unity. The volatile environment on Avalon made creating stable societies a challenge. Historically, societies would sprout only to fall to waste years later by famine, discourse, or even falling into the oceans. With all the setbacks Avali endured in their home world, they achieved several stable societies, with some continuing to modern times.

FORMATION OF SOCIETIES

Avali started as hunter-gatherer packs that consisted of 3-6 members. These members form strong bonds at the young kit stage. Packs wander the moon, searching for ample food supplies and sleeping areas. Their nomadic lifestyle allowed them to forage for newer tools and strategies to hunt and safer places to rest and sleep away from hostile fauna and environments. Packs would intermingle to trade goods, information, and mating. The members of packs are rarely genetic relatives, as eggs are often grouped in clusters for warmth and safety—more on [Hatcheries](#) later in the chapter.

Packs would become a foundation for making society work with Avali. Having an individual ruler over all members is very foreign to them. Instead, they rely heavily on each other, some members taking on roles to sustain the pack. Pack dynamics are designed so members can do or maintain specific tasks without depending on a single individual. Most packs have a leader, usually the eldest, most skilled at a particular job, or most charismatic. This leadership role does not prevent the leader from not performing other tasks. Pack leaders also represent a pack or deal with possible political matters. Depending on the situation, the pack leader role will rotate within the pack, given the necessary skill traits to survive. Decisions are made together as a single unit.

As the packs progressed, the unity between each other grew. Packs would evolve into tribes of Avali, a group consisting of multiple packs. Packs would also develop into specialized fields, contributing to the tribe collective. A basic form of hierarchy grew amongst these tribes, emphasizing the collective being the highest priority and individualism being more of a taboo. The ousting of individuality was formed for survival, as the collective needed food, hydration, and shelter. Each Avali is often found to have

various skills and can express themselves through certain outlets.



Figure 2 - Example of a Tribal Camp

Tribes consist of 4 or more packs of Avali, which their leaders unify into a single unit. They often develop their internal memetic cues, languages, and customs. Some tribes on Avalon have long lineages of packs, carrying on older traditions and customs. As time progressed, Tribes would intermingle with each other, which resulted in sharing information, goods, and packs. In some instances, tribes will unify into a larger collective, turning to a colony, or would wage war. Tribes are known for claiming certain territories for control. Regions are selected for their resources and stability. Tribes would migrate within these territories to stay close to food and resources as the environment changes.

Territories are large areas that remain unchanged for more than one year. These areas usually include common hunting grounds and rich resource areas. Due to the constantly changing environment, territories would often be redrawn or disappear entirely. These environmental changes would often lead to

controlled territories having multiple tribes within them. Tribes would often intermingle and trade or fight over resources. Areas under control would often be identified by some form of marker, like a tribal banner, streamer, or etched markings.

Tribes and controlled territories that often mingled together would eventually form an Avali Colony. Colonies are two or more tribes unified under one lead pack, usually consisting of elder or intellectual Avali. Colonies are still migrant, found with large caravans, but the resources gathered go to a centralized location. The structure of early colonies was in a somewhat circular pattern, with the central being for resource pooling and common areas and the outer layers being various tribes and packs. The centralization of power to a designated pack begins the first forms of government for Avali. Leader packs would start to direct packs and tribes to obtain specific resources and migration patterns and begin recording and implementing laws and education foundations. The centralized power also came with hurdles for Avali to overcome, as certain tribes and packs would feel under-represented within the colony. Most found the constant rotation of power through the pack and tribal voting systems to be the most effective and stable. In contrast, other forms, like dictatorships, would cause packs and tribes to



Figure 3 - Territorial Claim Flag

break away from the colony and develop new colonies.

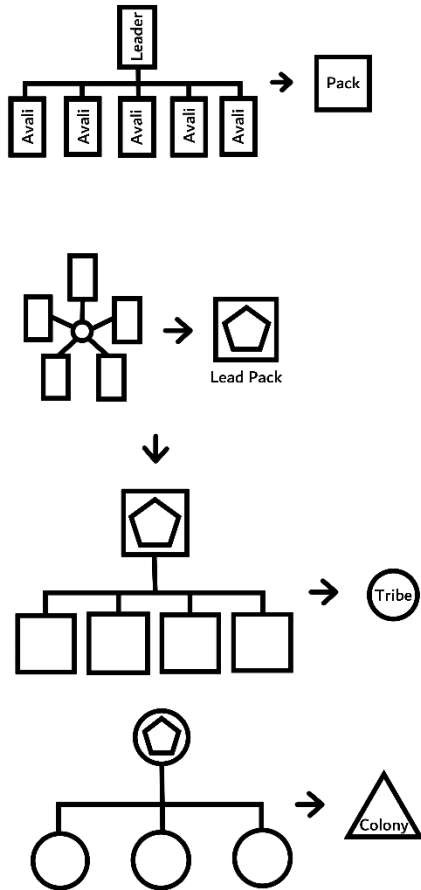

Figure 4 - Pack, Tribe, and Colony Hierarchies

As time progressed, colonies would migrate to the solid bedrock areas, to the dense megafauna forests, or Avalon's most stable ice shelves, and become stationary. These colonies became cities, and technology and education development began to expedite. Cities would find themselves as production powerhouses of Avalon, sitting on vast amounts of resources. Their stability and central location of resources attracted more tribes and colonies looking to escape the harsh Avalon environments. However, as fast as Avalian cities grow, they fall even quicker. Common issues plaguing cities were sourcing a stable food supply, changing environments, and governments.

Figure 5 - Avali Civilization Claimed by Shifting Ice Sheets

Cities are divided into sectors and controlled territories, which surround a central core. The city's core is the central government's home, resource storage, and in more modern times, power generation. The core feeds out into the sectors and territories. A sector would represent a single colony, a nearly self-sustaining unit that houses bedding accommodations, workshops, kitchens, common areas and chambers, hygienic stations, and resource warehouses. Territories are controlled plots of land, home to resource mining operations, farms, and outlying tribes that hunt and scout the environments. Territories often have warehouses that receive supplies from the core to maintain themselves.

Avalon has reclaimed nearly all other forms of civilization. Across Avalon, very little remains in former civilizations. Ancient Avalli cities are scarce and are found across mountaintops. The lack of early stable societies and central knowledge hubs hindered Avalli during the early phases of their development. Consequently, this has locked a lot of Avalli into migrant tent tribes and colonies. In modern times, it is prevalent to see migrating tribes and colonies still wandering the moon of Avalon. These groups have adapted to the changing times, utilizing new technologies to maintain themselves and obtaining resources from the city hubs. Avalli have also returned to ancient cities over time, refurbishing and developing them further, primarily due to the limited

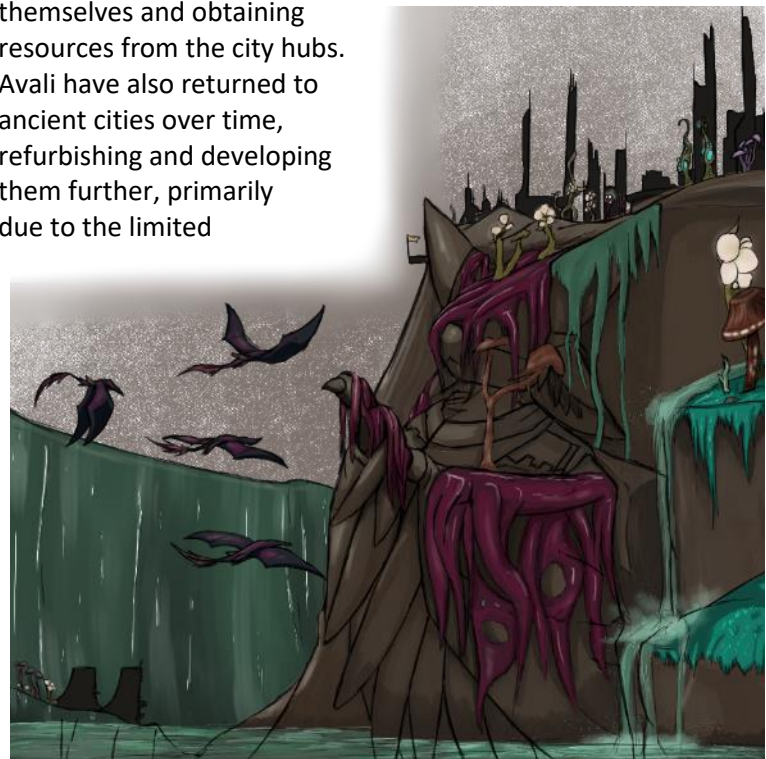

space for stationary settlements.

As the progression of cities advanced, the size of the centralized government proliferated. Lead packs would form into governing tribes, with individual specialized packs leading certain aspects of the city. Record keeping, education, and public services such as hygiene, policing, and standing militaries also became more prevalent in these cities. The constant expansion of cities caused borders to collide, which resulted in varying issues for control over resources. Certain cities that banded together would create a Region, while others would continue to contest each other over resource control.

Avali would develop in many parts of Avalon, and each territory would adopt a unique style of life. Each territory would develop unique customs and languages based on its environment. Avali that grew in extensive megafauna forests would find themselves only going to the ground level to hunt. In contrast, mountain societies would have intricate networks of caves and tunnels, housing resource processing, and livestock farms. Certain parts of the oceans also had floating cities and colonies, as Avali would find themselves afloat at sea. In these instances, Avali would become experts at ocean fishing. Trading amongst these unique societies and cities would see ideas, inventions, and resources exchanged, creating dense networks of relationships and cohesion. Trading also allowed certain territories to obtain otherwise scarce resources, allowing colonies and cities to continue developing and thriving. Due to the shifting world, Avali societies and cultures would often come together as certain cities and colonies migrated into each other for survival. While rare, wars would often break out due to these forced unifications, especially when a society becomes exhausted of resources.

In the time leading to modern-day societies, the world found itself in an extensive and costly civil war. The warring factions, the

Traditionalists, and the Illuminate, fought for resources and control over every facet of Avali's life. The Traditionalists aimed to maintain the collective ideologies of Avali, wanting Avalon unified under one group of leaders and remove those who sought to deviate from the establishment. The Illuminate aimed to unify the collective power of the cities, pushing for further technological progression and freedom of learning and leaving the outliers to their methods and ways of life. The Illuminate would be victorious in the war and would spend decades repairing the world the war destroyed. The war's destruction nearly wiped out the Avali.



Figure 6 - Illuminate Tri-feather Emblem

THE ILLUMINATE

Coming to power after the Great Civil War, the Illuminate Central Government became the sole authority on Avalon. Although the Illuminate power is far-reaching into the lives of Avali, independent tribes and colonies still exist outside their sphere of influence. Despite this, these independents continue interacting with the Illuminate for goods and services. Their control over the cities and

production has allowed them to remain in power and maintain a stable, flourishing civilization.

The Illuminate is a centralized, AI-assisted Technocracy. The AI, known as the "Oracle," uses a complex system of statistics and algorithms to determine growth and development, logistics, and production targets. This strategic control of each city and colony allows the Illuminate to set milestones for productivity and civic goals. Additionally, Oracle allows for rapid changes, adjusting goals and production levels to meet speedy demands. At the helm, a central tribe of specialized technical experts of nearly each critical career field continue to input and disseminate information to their respective fields.

Additionally, the technical experts can take innovations and newer technologies and simulate their production and civil impact needs before implantation. Furthermore, testing new technology paths is continuous, allowing for possible alternatives and further development. The technical experts are chosen every five years, allowing fresh minds to enter the central government and rotate the control of the power to newer Avali. These experts are selected by popular vote and board review within the respective career field. The

The Illuminate's reach extends beyond Avalon. As Avali began to venture out into space, they did so under the banner of the Illuminate. They nearly all the mining stations, spaceports, and space habits developed within the Uresk star system. While being the prominent Avali presence in the galaxy, the Illuminate tend to be reclusive and isolationist, putting the needs of the Avali and Avalon above all else. The Avali also have little desire to leave their home system and settle elsewhere, as most are content with living on and around Avalon. This hesitance is rooted in their biology,

prohibiting many worlds from being habitable, while most races consider them ideal.

The Illuminate also controls the primary currency, known as "Lumes" and "Bits," which are a fraction of a Lume. This centralized and serialized currency incentivizes Avali to perform work duties and services. The Illuminate will establish production quotas and reward Avali packs for meeting these quotas within a specific time frame. Producing more than the quotas is also rewarded with further credits. Excess products are sold to other tribes and colonies. Personal Lumes are exchanged for other goods and services, such as artworks, plays, additional food supplies, different or more elaborate accommodations, and personal care. Lumes are

usually taxed back into the Illuminate system, where they are redistributed as incentives and goods.



Figure 7 - Lume Digital Card (top), Lume Symbol (bottom left), and Bit Symbol (bottom right)

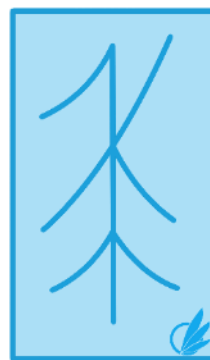

Lumes and Bits are all serialized with their identifiable sequence. The Illuminate dictates how

many Lumes and bits can be in digital circulation. Since all the currency is digital and centrally controlled, the Illuminate will often decertify a sequence of Lumes after a given date. The only way to obtain any physical copies of Lumes is through currency chips, which save

many Lumes. Commonly, chips create a secure way to carry currency by more remote and migrant tribes and colonies. They are also only usable through authorized Illuminate vendors and monitored systems. The value of the Lume itself is tied back to the production value made and the number of resources stocked on hand, collectively within Illuminate control. The total of all goods, products, and services produced within 1 hour of work is how much a Lume is worth. As such, each major city's products and services could be worth more or less than another, as each city has various production goals and supplies.

The standard of living for Avali under Illuminate control is exceptionally high. Compared to other galactic races, Avali's life is equivalent to that of a utopia. The government maintains an ample supply and access to food, clothing, housing, medicine and medical care, tools, and appliances for their citizens. The Illuminate also provides policing and military forces for defense within cities and colonies. Avali can also run and control their businesses, selling goods and services to others for Lumes. While the Illuminate collects most basic goods produced for redistribution, certain products offered by outside colonies and tribes, like rarer materials, organic pelts, artworks, and services, are not directly controlled by the Illuminate but are handled by a cycle and taxation of Lumes within the system. This taxation allows the Illuminate to continue their incentives and supplies a stable economy outside of the Illuminate's control, as Lumes are used to incentivize Independent workers and the production of goods.

One of the early controversial aspects of the Illuminate was population control. Due to the Avali's carnivorous nature, the balance between food supplies and population has been challenging, even before the Illuminate took power. The Oracle system predicts how much

growth is expected within the society and dictates how much the population can expand based on food supplies. During the policy's existence, Illuminate distributed large quantities of contraceptives and tax credits to discourage pregnancies. In more extreme cases, eggs are cracked and removed from hatcheries, a certain number of which were determined by the Oracle AI. This policy has since been relaxed, allowing the population to grow more naturally. This is partly thanks to the continued development of food processing and synthesized meats. Avali are much more vigilant about having offspring, some even electing not to have any or removing the ability to have eggs. Some colonies and cities also provide breeding permits to control population growth further. While the policy is no longer in place, the scar remains and is a constant reminder of how easily society can collapse if basic needs are unmet.

The modern Illuminate logo can be seen nearly everywhere with Avali's presence. The iconic logo is the famous three-feather cluster on a circle. Originally signifying the first three fleets to leave Avalon, the logo has grown and evolved to a newer meaning, more representative of the Illuminate and the Avali people. The circle indicates the global reach of the Illuminate on Avalon. The cluster of three feathers represents a pack, which is the sole foundation of Avali society. Each feather tip forms a point at the base, representing the significance of the pack being a single unit. The feathers represent a closely held value of the Illuminate people. The top feather of the cluster represents societal unity. The middle feather represents technology and its integral role within society. Finally, the bottom feather represents the Sciences and the critical advances made in each field—all form together as an orange logo, Orange representing the rich culture of the Avali people.

INDEPENDENT TRIBES

The Independents integrate the Illuminate currency and technologies into their tribes and colonies. Tribes that exist outside the influence of the Illuminate but interact with them are known as Independent Tribes. A bit of a misnomer, as Independent applies to packs, tribes, and colonies. Nonetheless, the Independents do not strictly abide by the laws set in place by the Illuminate. They often dictate themselves and their operations.

Independents usually pride themselves on having different customs and styles from the Illuminate. However, their divergence is moderate to separate themselves from the Illuminate. Thanks to the incorporation of technology, Independents' packs, tribes, and colonies can integrate into and out of Illuminate ones well enough but still maintain enough of a different identity to be unique.

While Independents operate under their desires, they are often given work by the Illuminate. The work orders given out by the Illuminate are usually for scouting and resource identifying, establishing a small tribe presence on a resource, providing logistical support, or gathering food resources. In some instances, the Illuminate might assign a lead pack to ensure all the needs are met in the work order. Depending on the agreement, the Independents may have little control of a resource or project once completed.

An example of an Illuminate work order for an Independent tribe would go as follows. A tribe might be copper miners coming together to mine out a newly discovered series of copper-rich cave systems. The Illuminate will create a work order to obtain a specific volume of resources within a specified timeframe. They will assign a leader pack with experience in the mining and distribution of copper and release an inventory of equipment such as mining drills and trucks, drones, storage units, and

appropriate protective equipment needed to complete the project. The lead pack will recruit the right Independent pack specialists, such as drone specialists, engineers, surveyors, support staff, and miners, to complete the project. In addition to promised benefits, production above and beyond the demanded work order also becomes the possession of the tribe to trade or use as they see fit.

Independents are more open to galactic communications, though prefer to be left alone to their own devices. Small off-world habitats, space stations, and mining stations exist within the control of the Independents. While not under the alliance of the Illuminate, settlements rely heavily on the Illuminate for resources and work. Some colonies are also seen to have other galactic races living and working amongst the Avali.

ROGUE TRIBES AND COLONIES

Rogue Avali tribes and colonies deviate entirely from the Illuminate's grasp and actively avoid or conflict with the Illuminate. Rogues are viewed as deviants and outcasts from the Illuminate or Independents. The Rogue nomenclature applies to tribes that refuse to conduct economic activities or even remotely adopt technology and civics from the Illuminate.

Some rogue tribes and colonies are traditionalists. These Avali shun modern technology and prefer to conduct themselves as their ancestors have before them. These Avali are seen as little threat to the Illuminate or Independents, as they are reclusive and actively avoid both parties. Traditionalist Avali can be found scattered across icy plains or dense forests, conducting their daily lives. Despite their best efforts, the more traditionalist tribes are dwindling on Avalon, as most have turned to the Illuminate for help and resources.

Other rogue tribes are vicious and criminal. These tribes are centralized criminal

syndicates that actively steal from the Illuminate and Independents to sustain themselves. Some of these rogue tribes are just the centralized version of these thieves. Others vigorously attacked the other tribes and colonies to gather resources and new pack members, often holding them for ransom. Avali, being predatory, have had issues with thievery since the inception of societies. These pirate tribes embrace their origins as apex predators and view it as natural that they should prey upon other species, materially, technologically, and, in a few cases, literally. These pirate-like Avali are often pursued by the Illuminate to be permanently dispatched.

To the Illuminate, it does not take much to be deemed a Rogue tribe or colony. In some instances, certain policy violations, like control of production facilities and goods, are enough to be considered a Rogue tribe. In other cases, the Illuminate tend to wait until the tribe begins to falter and then proceed to aid them. When situations like these arise, the Illuminate will sometimes dispatch a leader pack to return the commune under corrective control.

Rogue tribes also supply mercenary packs that specialize in performing black-market activities. An example of black-market activities includes egg snatching, which involves a pack stealing from a hatchery, providing guns for hire, or smuggling goods under the eyes of the Illuminate. While some Rogue tribes scoff at working with or coexisting with other galactic species, others capitalize on the opportunities. The wide range of Rogue tribes makes it hard to dictate a distinct good and evil to some, as these tribes exist solidly in a gray area.

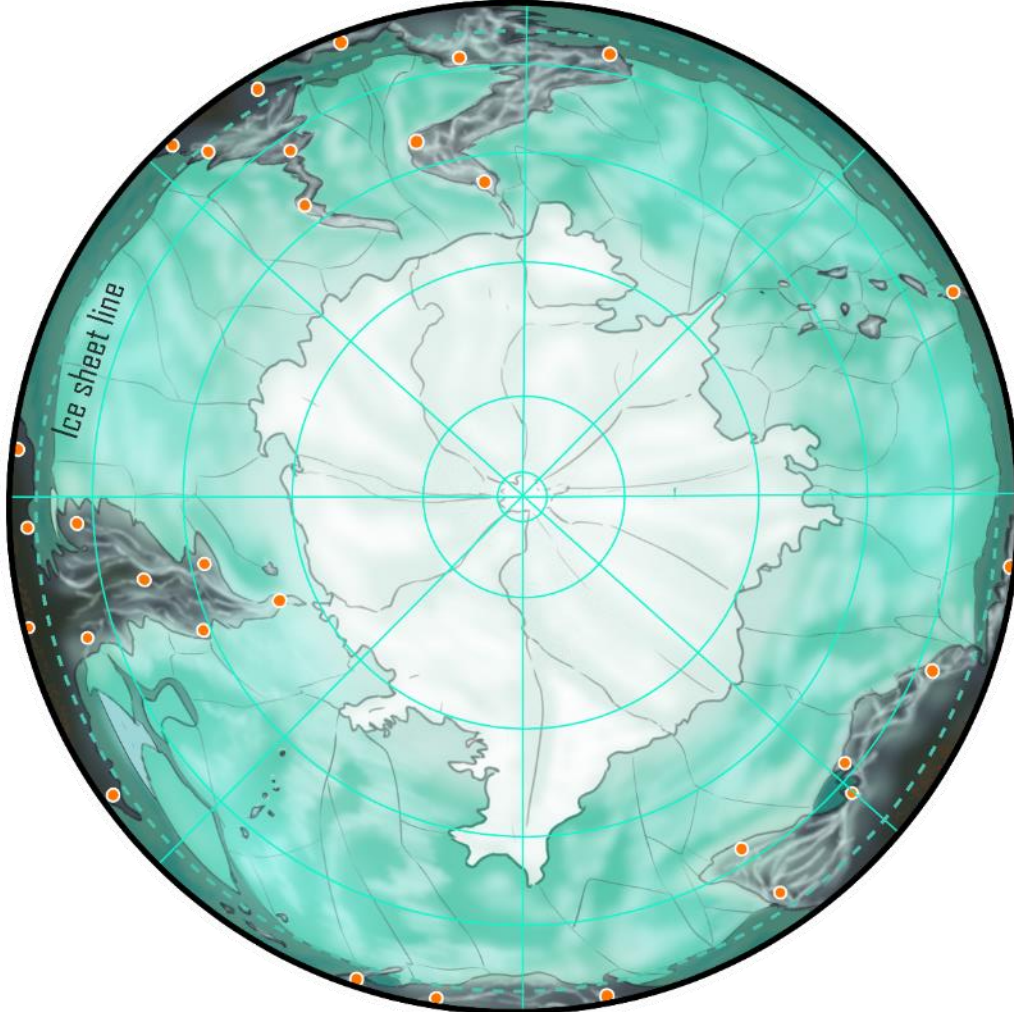
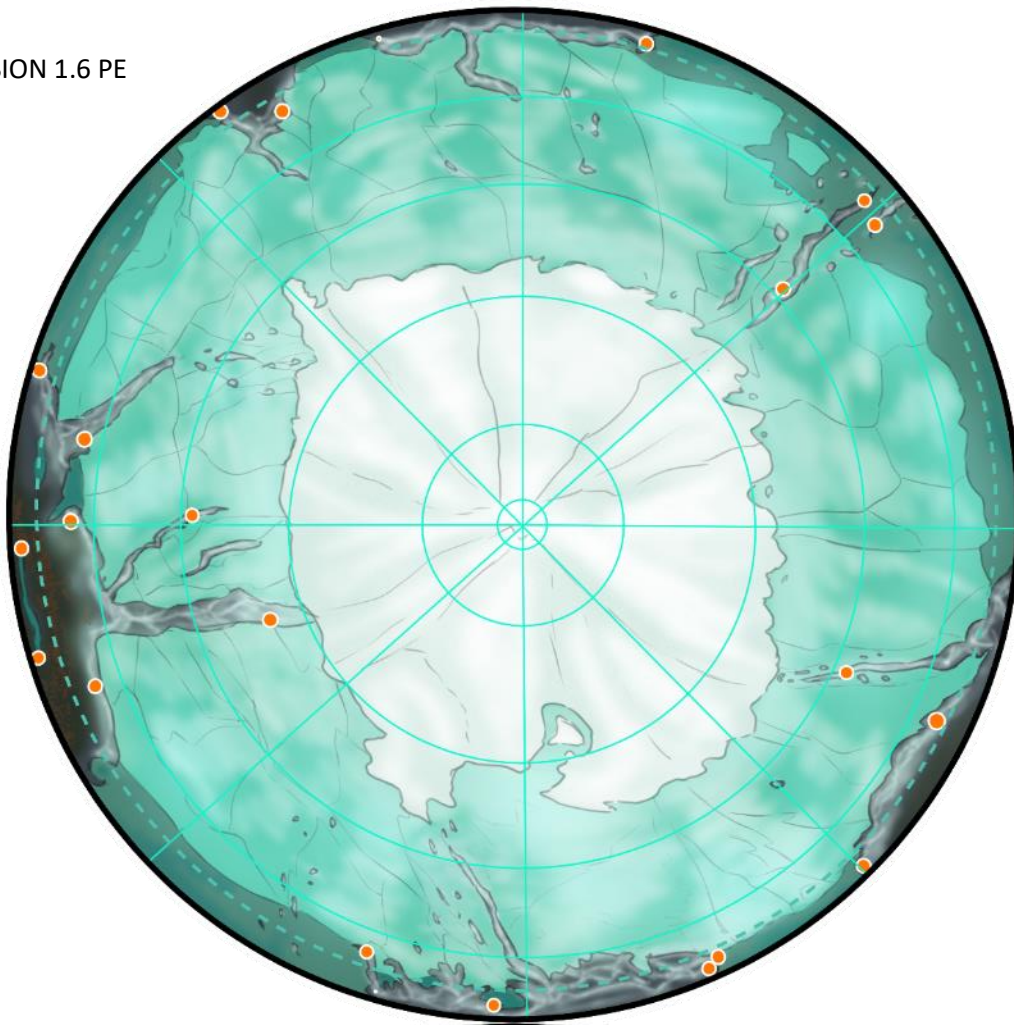

Ice sheet line

Major Illuminate City



BELIEFS AND BEHAVIOR

“Avali are interesting because everything they do is a pack activity. You often get weird looks from them when you request individual Avali to perform certain tasks.” -UNoE Ambassador Isaac Gutierrez-Sanchez.

Avali are pack based and know their efforts contribute to a larger collective. The formation and success of a pack are essential to an Avali. Avali begin to form pack bonds during their hatchling and kit phases. Although members of a pack are not genetically related to each other, the bonds they form are very family-like. Each Avali cares for one another, like a healthy human genetic family. Avali packs will collectively specialize into a particular set of skills, such as mining or record keeping. These specialties are determined by pack leaders of tribes, colonies, or cities based on what is needed. While the packs are highly specialized, technical experts in their fields, the individual Avali can also have different skills, such as art making, singing, programming, etc. This skill diversity allows for a unique level of versatility between each pack. Consequently, innovation and development of new ideas also spawn from packs outside specialty careers. Adult packs

usually adopt a pack name, or members will adopt a former common name to signify their specialty, origin, or continuing tradition.

Nearly every aspect of an Avali's life is based around the pack. Avali will sleep together as a collective pack inside tents fitted for them. Clothing, eating, relaxing, learning, and other activities are done with the entire pack's involvement. On rare occasions, Avali will leave to run short errands, such as gathering small materials or resources. During slow times, when Avali are not performing primary duties, pack members will gather with each other, sing, and preen each other's feathers. For bathing, Avali use warmed liquid ammonia or bathing in dust baths using fine water crystals, water-based snow, or other dry particulates that serve well in cleaning feathers. The building of small nests for sleeping in is also accomplished during this timeframe, utilizing animal pelts, feathers, softened wood chips if available, and water-based snow. Most modern Avali today use a series of heavy blankets and pillows to build up nests and hollows. Bathing in either dust or ammonia is commonly done in communal bathing areas, though some smaller, pack-sized areas are also frequently used. The modern-day Avali is never truly separated from their pack. Avali have developed intricate communications technologies to allow for constant interaction with each member. Furthermore, the technology interlinks and extends out towards the entirety of Avalon. More on the collection of robust communication arrays and servers known as "[Nexus](#)" later in the chapter.

Pack mentality does not stop Avali from having their forms of expression and ideas. They can be found styling their crests, wing feathers, and tails with dyes and heat, giving a unique individual design to themselves. Avali will also wear specific clothing items, sound-making devices, and jewelry. Another form of individualism comes from the hobbies and skills

Figure 1 - Modern Hunting Avali Pack



that pique their interest. A large and central part of Avali's culture is making arts and musicals. Each member can choose which instrument to play or express themselves in artwork like painting or songwriting.

THOUGHT PROCESSES

Avali thought processes are unique. They have complex brain structures but rely heavily on each other to accomplish complex tasks. While in no way dumb, the individual Avali would appear not very intelligent to human standards at first glance. When operating alone, they struggle with prioritizing and hierarchical processing tasks, becoming overwhelmed with complex or multitasking processes. When thinking, Avali would often call out or speak their thoughts, usually waiting for a response from another pack member. Thoughts are often sporadic, usually only retained during hunting or feeding. Their memory does not rely on visual cues but focuses more on hearing, emotions, and associated actions. Since visual memory is difficult for an Avali, visual learning cues are often not used for teaching, instead relying more on audio and tactile teaching methods. Avali can be taught to use visual cues to recall memories, though the process is unreliable and takes many years of training.

Avali generally don't think about themselves. The concepts of the individual are different from that of humans. Instead, the pack would be considered as the individual. Avali will always think of their pack first over themselves. They will think of what the pack needs, where it will sleep, pool, and use resources for it, and will receive rewards based on the pack. Avali exercise some individual freedoms, found in their arts, clothing articles, personal computing devices, some small hobbies, and relieving themselves. Outside of these freedoms,

everything else is done with and about the pack.

Figure 2 - Avali wearing traditional hunter garments



Complex task processing, which requires multiple parts to be completed to achieve an end goal, such as computing advanced mathematical formulas and performing mechanical work, often requires a pack involvement instead of solely relying on individuals to compute or complete tasks. The pack will depend on its designated leader to command tasks for accomplishment. Each Avali will perform a part of the task to be completed, solely focusing on that task until completion. The lead will track the progress and continue command until the goal has been achieved. Optimal pack sizes are 3-6 Avali. 2 Avali in one pack have difficulties processing tasks, as both would be unable to establish a leader and create a hierarchy to accomplish tasks. Over 6

Avali cause multiple leaders to be selected, creating infighting amongst the pack. Packs will then separate, causing all to experience Pack Loss.

Avali alone are capable of some complex low-level task-solving. Simple arithmetic and science formulas, navigation, and processing data are some examples of this. When Avali are tasked to complete a more intense task, they cannot distinguish important aspects over others, making all processes a high priority. This lack of prioritization will cause the individual to become overwhelmed with the task, which leads to them freezing, looking for help, or focusing on accomplishing tasks in odd orders. Avali often forgot to eat, hydrate, or sleep, causing memory and speech issues. In limited cases, Avali can be trained to complete complex tasks after years of intensive training.

EXPRESSIONS AND SOCIAL DYNAMICS

Avali love to talk. They will continuously talk about ideas, thoughts, and emotions. Avali tend not to keep secrets well amongst other members of their pack and have little in filtering out their ideas. The pack, as a collective, however, will keep secrets well amongst each other, and one would find it very hard to get the secrets out. Since Avali have difficulty filtering out their thoughts well, some may see them as rude or crass. To the average Human, they sound whisper-quiet. Their soft speech is due to their sensitive ears not requiring a higher decibel range for communication. Avali can reach wide vocal ranges, thanks partly to their constant singing and communication.

Avali express a lot of sound-based emotions. Because of their chatty and expressive nature, their

primary language is quite complex, with certain expressive sounds and word sounds combined to form a language and meaning. Certain facial expressions translate well to humans; however, these expressions should not be relied upon for correct emotional engagement. Avali will often let out certain pitches and variants of sounds, bits that express a wide range of emotions, combinations that are almost their form of language. This style of record keeping has allowed Avali to record feelings and expressions well on documents.

Physical expressions are done using their ears, tail, and occasional body and face movements. Ears and tails will perk or droop depending on their moods. They are observed leaning into conversations or using their hands while conversing. Grinning, smiling, baring of the teeth, frowning, and scoffing are all common facial expressions that translate well to human viewers. Other facial expressions, like the clacking of the teeth, whistling, eye squints, and agape mouth, are some that only some translate well to humans, as some are a little too alien. These examples mean the following; clacking of the teeth usually means in thought, feeling threatened, or preparing for an attack. Whistling is typically a sign of uneasiness, calling



Figure 3 - Avali dressing each other

for help, or a warning sign not to be bothered. Eye squints have an extensive range of meanings, but most are attributed to being in deep thought, confusion, or anger. The agape mouth can refer to listening for input or hunger.

Insults, aggressive speech, and gestures are commonly made with wings and upper ears. When Avali get aggressive, their skirts and tails flare outwards. When insulting, their upper ears tend to be perked upwards, whereas when ready to attack or prepare a defensive posture, the ears lay flat. The use of the wings helps exaggerate sounds and speech. Flapping the wings towards individuals or packs is a sign of aggression in certain situations. Gestures made with the hands are also much more common, like placing two fingers between the other two indicating a "shove it" response. The speech will become filled with growls and hisses during or after talking. While most interactions are spoken in mild tones, packs will often gather and attempt to overwhelm individuals or other packs with sounds. Higher-pitched screaming or screeching from Avali during arguments or fighting does not happen. Instead, Avali will make a hiss-clicking sound or growl during this time. Screaming or screeching happens for pain or when in critical need.

Affection and love come in many different forms for Avali. Nuzzling is one of the most common forms of showing affection between pack members and friends. Nuzzling is used as a greeting, parting ways, or showing appreciation. Hugging one another, nuzzling under the chin, and cuddling are other forms of affection, while cuddling is more for safeguarding another member of a pack, friends, or offering emotional stability. Licking cheeks and ears amongst pack members is a form of love and comfort, while other acts that involve licking or playful nipping are seen as interest in mating. Stroking and petting of the head feathers, ears, and tail feathers are used

to relax and destress pack members. The sharing of feathers is another form of great gratitude, love, or appreciation for another Avali. An Avali would share their feathers usually with other pack mates, significant mentors and teachers, and close friends. Pressing their snouts against something is a way to express ownership, attachment, or interest. The feeling of being flustered, usually attributed to human blushing, is seen in Avali as their cheek and ear feathers flare up, usually causing their eyes to close and a soft purring.

Although the bonds are not as solid nor significant as another Avali member, the uniqueness of forming bonds outside of kit members allows Avali to handle situations in which they find themselves alone. Certain animals that Avali have deemed as pets are better for these situations than drones; however, drones are more versatile and much easier to replace. Pack imprinting can also happen with pet animals, alien races, and certain drones. Alien races are found to have more difficulty establishing initial bonds, and specific language barriers, environmental factors, and personal beliefs can interfere with the bonding process. These barriers have not prevented some races, like humans, from bonding well with Avali. Some would even find their bond with their Avali to be an extremely close friendship: if your friend loves to share every intimate detail with you and would like



Figure 4 - Avali with a bolvine-like creature

help dressing them.

Animals on Avalon are viewed differently than how Humans would. Most animals on Avalon are treated as food supplies. The care for the animal is not as much of a concern as their ability to sustain an Avali. Thus, Avali treat animals as food and nothing more. The success of the animal only comes in breeding for the continuation of a stable food supply. Avali do not perceive animals as an individual, more so as objects. Creatures that pose more of a threat to an Avali are avoided unless the pack of Avali can dispatch them. A few exceptions to this rule apply to certain animals deemed too toxic for consumption, critical for caravan movements, or animals that bond quickly with Avali.

More traditional or ancient tribes of Avali have a diminutive form of religion. These tribes carry a belief system of all things on Avalon having a spirit, and those that have lived and died are a part of a larger central essence. Packs and unions make up an enormous spirit and a singularity end goal for all Avali. While very few tribes believe in this, modern Avali do not continue this belief system, and most find it bizarre or offensive. Despite this, older tales, stories, and occasional pack naming schemes are still seen and told, such as adopting old, long-dead pack names. Some older traditional-style tribes and packs hold an honor system for what they deemed noble spirits and still practice the religion. These Avali shun technology and body augments, opting for a more natural way of life. As such, with their belief systems, modern Avali find the practice or strict adherence to religion by alien races to be very odd. As such, authorities such as the Illuminate highly discourage the participation and practice of foreign religions. The strict enforcement of such is easy, as Avali shy away from such beliefs.

Avali love to augment themselves, trying to overturn the drawbacks of their evolution. Traces of augmentation trace back to very early tribal communes. Avali would use clear crystal lenses to see further and identify objects and symbols. Avali would also develop crude replacement prosthetics for missing limbs from unfortunate hunts. These early forms of augments are more commonly seen in modern Avali, with eyes being replaced, the everyday use of visors and eye lenses, and the heavy use of exoskeletons to manipulate resources and manufactured goods. Other standard augments found on Avali are wing replacements and body temperature control modules to help regulate heat. In more extreme cases, some Avali have opted to forgo their biological bodies instead of a complete cybernetic replacement that houses their brains. While these extreme cases are few and expensive, the technology exists.

Wearing clothing is something more modern Avali cultures have slowly adopted. For most of their existence, Avali wore little to no clothing. Standard pieces like jewelry, utility belts, and satchels were the only pieces that were often worn. Traditional-looking garbs used for mating or recreation are also common. In their modern world, clothing is used for jobs and particular events. While much more common than in past generations, it is still infrequently used. Clothing is also a pack affair, requiring the pack to dress each other as articles of clothing are put together. Nude Avali are a common sight and casual nudity is often preferred whenever relaxing.



Figure 5 - Examples of plants that offer a cotton-like fiber for harvesting

HATCHERIES

Hatcheries have been a core part of Avali society since the beginning of pack-making. Hatcheries are characterized as a central location, usually protected and developed, where female Avali go to brood and lay their eggs. In the early ages of Avali development, hatcheries utilized burrows, hollowed mega-trees, or cave systems. As

technology and Avali society developed, so did their hatcheries. They would

eventually become large centralized tents in tribes and colonies and later large, stationary buildings with banners of multiple colonies and cities flown.

Avali are only able to lay a single egg after a mating period. When eggs are laid in the hatchery, they are collected into small sets of 3-8. Clustering eggs has the added benefit of keeping the eggs warm during embryonic development. Eggs are placed in a soft, padded nest for safety. Early nests usually consisted of pelts, flora chips, and preened feathers. The padding allowed the Avali to keep the eggs in a comfortable location for the Avali to stay warm. In the past, hatchery workers would nuzzle eggs to inspect for proper temperature. Modern nests are much more sophisticated, using heaters, pillows, and dense cloth such as cotton-like fiber blankets and woven nano-canvas. These materials also allow the nests to be cleaned and sterilized after the eggs have hatched. After laying a fertilized egg, an Avali would take a few days to recover from the process, as the large size of the egg puts much stress on the body. Hatcheries have recovery areas for Avali to recover in.



Figure 6 - Hatchery Guard, posted outside of the structure.

Hatcheries are held sacredly to Avali. Historically, hatcheries are deemed safe and noncombatant zones, and packs or tribes that violate this pact are dealt with harshly. Hatcheries are also very well-defended, usually built up like heavy bunkers. Pack hatchery workers and guards are traditionally held to a higher standard and scrutiny than most Avali. These packs are also seen as working in an honorable profession. As such, they will undergo a thorough screening before being assigned to hatchery work.

When the eggs hatch, the hatchlings are taken as a cluster to a separate area, where they are fed, cleaned, and watched over during the first few weeks post-hatching. During this period, the hatchlings begin to make bonds with each other. Afterward, the young kits will start learning activities and games, schooling, and specialty training.

Most modern colonies and cities utilize eggs for their cells, harvesting and modifying them for limb replacements or medical

Unfertilized

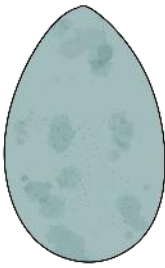

Fertilized

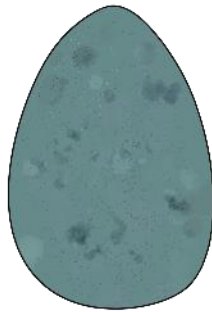
*Figure 7 - Avali Eggs*

treatments. Inert eggs, or eggs that have not been fertilized, will be laid in hatcheries. The inert eggs, identifiable by their lighter [teal color and smaller size](#), are removed from hatcheries for disposal. Thanks in part to their smaller size, inert eggs are far easier to pass than fertilized ones, making the recovery process significantly faster. Female Avali typically recovers within a day.

AVALI KITS

Avali children, known as "kits," are not raised by their biological parents like humans. Instead, kits are raised as a pack, with the efforts of the whole Avali tribe, colony, or city sectors. Each pack will have assigned mentors and trainers, teaching kits, basic things like food hunting and preparation, clothing, and basic technologies, up to

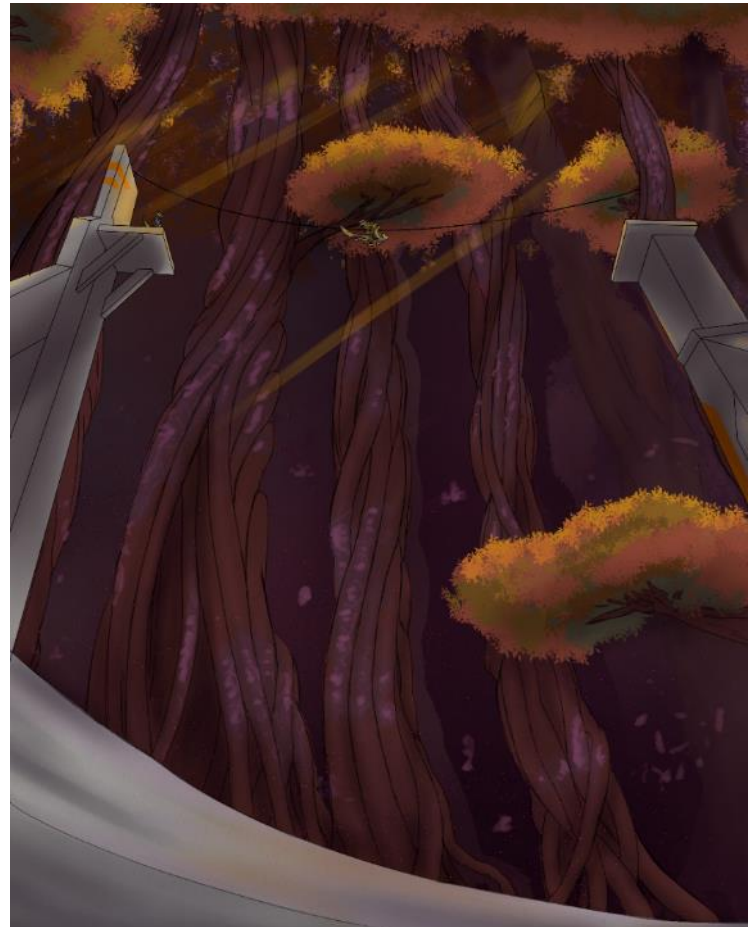
*Figure 8 - Avali kit, post first feather development**Figure 9 - Example of Avali Kit flight school*

more complex and specialized tasks such as mathematics, programming, and navigation. Modern-day kits are raised on campuses and in large dormitories, where they will reside until they grow out of adolescence.

Kits will start their basic training within large hatcheries or another designated area. The teacher packs will train kit packs, developing their social skills, bonding, and language. As kits progress, they will graduate into hunting and gathering phases, becoming acquainted with either captured prey or in-field training with another hunter pack. In the more advanced levels of hunting and gathering, kits are taught to make tools and weapons and where to find the materials to make them. They will also be taught the preparation and storage of their hunted prey or captured foodstuffs for later consumption.

During adolescent kit phases, ages 10-20, Avali will be placed in a more schooling environment, where they will learn and refine skills such as mathematics, language, literacy, sciences such as physics and biology, and social studies. Along with completing these courses, kits will continue to hunt, gather, navigate, or in more modern cases, learn arts, crafts, and computer programming. In this stage of the pack's life, they will also be given unsupervised sleeping accommodation as they learn to rely more on themselves to sustain each other. While unsupervised, the pack can still fall back on their assigned teacher or mentor pack or the tribe for guidance.

Graduating to the young adult phases of life, the pack will start to train on their specialized career field or skill set. While some are assigned at birth, situations and flexibility can allow the pack to change specialties at this stage. Once selected, the pack is given to a technical leader pack, where they will begin training on skill sets. The training can range from book studies to on-the-job training exercises. Specialty training usually takes 1-2 years to complete, though some more intensive or complex careers or skills require longer investments. Upon completion and certification from the technical leader pack, the pack will officially begin their duties, to which most will dedicate their entire lives.

In rare cases, young kits struggle to bond with their assigned pack. These kits are often shy or struggle to handle social activities. During these instances, the Avali kit will be removed from its given pack and undergo a therapeutic training sequence to help eliminate the underlying shyness or struggles. The training also involves the kits reassigning to a new pack, which they will most likely bond to new kits. This process must be done during the early stages of Avali's life or rapidly in adolescence.

Otherwise, the young kit will start to experience Pack Loss on top of concurrent issues with bonding with packs. In more modern cases, kits like these are augmented to handle social stresses.

PACK BONDING AND LOSS

Pack bonding outside the kit stage is a complex process. Depending on the severity, a lone Avali can easily re-bond with a new pack or start to suffer from a mental disease known as "Pack Loss." The disease affects members of a pack that have lost one of their own, either to death or separation.

The pack bonding phase for a post-kit Avali includes constant interaction and activities with a new pack, maintaining a set schedule, monitoring well-being and mental state, and assisting medications to avoid extreme mental stress and symptoms. Active monitoring is necessary for the avoidance of pack loss symptoms. Avali are also placed on lighter work duties to prevent unnecessary stress, which can further worsen Pack Loss symptoms. Avali will experience generalized anxiety, insomnia, and under-eating issues during the bonding or re-bonding phase with the pack. While undergoing

Figure 10 - Avali suffering from Pack Loss

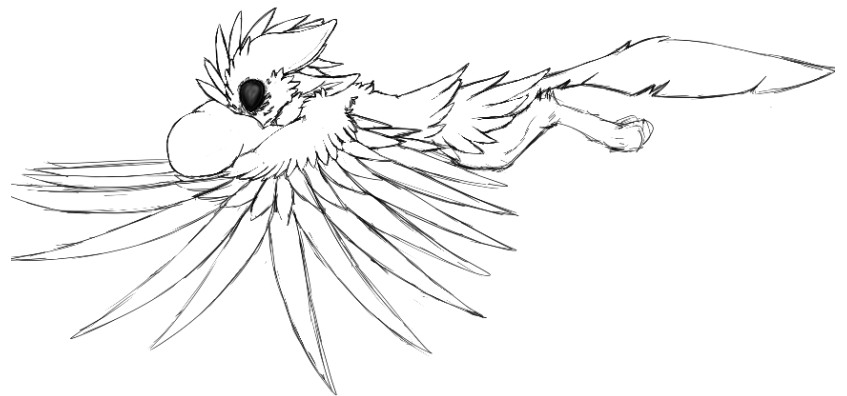

treatment, Avali will be seen regularly by a doctor and therapeutic packs to ensure a healthy bonding and adaptation back into a pack and society.

Pack Loss is the mental disease characterized by the removal of an Avali from their family pack or the loss of a member from a pack. Symptoms of pack loss worsen as the Avali no longer bonded with a pack, has become unintentionally separated from their pack, or has continued mourning a lost member. The disease can cause physical and mental trauma to the member(s) and needs to be treated with speed and care. Additionally, the excess stress caused by the disease needs to be mitigated. Avali are to be relegated to low-stress duties or activities, such as idly singing, conversing with new or current pack members, mild exercise, and inventorying goods. Creating a more stressful environment for the suffering Avali will only worsen the disease and possibly cause irreparable damage.

Pack Loss can be categorized into two main categories, each requiring a different level of treatment. These categories are Pack Loss-Traumatic and Pack Loss-Separation. Both Pack Loss categories have specialized treatments for Avali. The treatments are needed to avoid the worsening of symptoms.

Pack Loss-Traumatic is the sudden and abrupt removal of an Avali from a pack. This includes situations like sudden death or kidnapping. The beginning symptoms Avali will experience include mild to severe insomnia, moderate to severe depression, eating disorders, and generalized anxiety disorders. Symptoms rapidly deteriorate into disorders like Post Traumatic Stress Disorder, auditory hallucinations, and extreme paranoia. An Avali individual or pack will actively recuse themselves from certain areas or other Avali to avoid triggering these symptoms. When recovering from such traumatic events, Avali or

whole packs will be placed under monitoring and begin treatments to prevent worsening symptoms.

Pack Loss-Separation is when a member goes missing from the pack, not abruptly, or an older member has passed away. Additionally, Avali who have lost their pack or transitioning from one pack to another will also fall under this category. Characteristics of this form of pack loss begin with low anxiety levels, depression, trouble falling to sleep, and even infrequent auditory hallucinations. As time progresses, the symptoms become more severe and mimic those of Pack Loss-Traumatic. However, the deterioration is much slower and can be remedied easier during the mild phases. If symptoms become too intense, the treatment will be handled as though the Pack Loss is traumatic.

If Pack loss symptoms continue untreated or are not appropriately treated, Avali will have a complete mental breakdown and become what is known as "Feral." Feral Avali are characterized as having a full breakdown of cognitive functions due to the brain trying to cope with the extreme stress of missing a pack or pack member while only allowing essential functions to remain. Early signs of Feral stages include the inability to hear correctly due to hallucinations, involuntary muscle movements, paranoia, complete lack of sleep and eating, and large patches of feathers molting from the body. Avali that fall under this will likely go into a short coma, where they can be retrieved and appropriately treated, along with nutrition and extremely intensive therapy.

A rare condition during the extreme phases of Pack loss is "Pack Broken." Members who have developed this condition have their brains no longer rely on packs to function fully. While still able to recover from pack loss, these individual Avali will struggle with day-to-day life, finding interactions, work, and relaxation

activities to be taxing. These Avali will also become more reclusive from society, casting themselves out due to paranoia of individuals. While many treatments exist for pack loss, very few, if any, exist for treating pack broken.

ARTS

The Avali are a very artistic race. Creativity has become one of the most valuable assets a pack can have in modern Avalon. Given the incredible Avali [auditory processing](#), coupled with poor vision, musical, jingles, and performance art, like plays and dramas, tend to be significantly more popular than visual arts. It is common for Avali to have some degree of musical experience and can either play an instrument or sing. Many packs play together as a band, a tendency that begins at a young age as Avali kits often play games based on sound and music. Dedicated music pieces are usually found to be full and vibrant, though soft sounding as far as decibel ranges go. Music also tends to be slow to medium paced, running at a tempo of 90-165 bpm. These pieces often have multiple movements, with repetitional and alternating note patterns. Music notes are selected based on their vibration effects, usually favoring soothing ones over those seen as rash, explosive, or shocking. Human-style music is often heard as aggressive, hyper, occasionally screechy, and sometimes lacking in fullness or depth to Avali. This has kept specific Avali packs from finding occasional human songs enjoyable.

Artworks that use note patterning can also be seen as music, though they are classified separately. Some art pieces are often much shorter, usually lasting as short as 6 seconds to 1 minute. These short rhythms tended to deviate from the standard music format, usually favoring faster tempos, louder notes, and much more aggressive-sounding notes to invoke some form of emotion or action. Other art pieces are

very soft and natural sounding. These pieces are much slower, using long movements, and have minimal instances where notes will dramatically jump or drop in octaves. These pieces are appreciated for their usually calming demeanor and can be used to help relax and sleep. They also utilize instruments and other sounds to create a whole atmosphere.

Auditory arts also extend to the architecture of stationary buildings in cities. The tall, thin buildings often deflect and manipulate the wind, giving each city a unique sound. The inner workings of cities often echo and resonate with sounds of activity, sounds that Avali use to navigate shops, residential homes, and work centers. Drones, vehicles, and other machines are designed to mitigate unwanted sounds. In residential areas, Avali will often use tent fabrics, sheets, and other forms of sound deadening to reduce noise effects from the colony or city. Sleeping rooms, hatcheries, and common areas are the most padded areas. These are nearly completely silent, some allowing very faint sounds to bleed through.

Though fine visual distinctions are often wasted upon them, the Avali still appreciate intricate and high-contrast decorative patterns, as seen in their tent work and clothing. Packs have a set of colors, informal heraldry, that they prefer and identify with through their belongings and clothing. Often, the patterning of these cloth pieces represent a specialty that to pack is skilled in, such as computer programming or engineering. Avali clothing often integrates crystalline and metallic chimes into the garments as the auditory equivalent of wearing bright colors. A form of jewelry can also be worn by Avali, which can be seen as earpieces, neck pieces, belt accouterments, and wrist bracelets. To the average Human, the noise tends to drown out and blend; however, the Avali are no more confused by the melodies

of a crowd than the human eye is by the task of tracking a single face among dozens.

Unlike humans, the visible color spectrum favors more [infrared](#) Avali. It is common to see colors like oranges, yellows, reds, and patternings using such colors. These colors also look slightly different, with variants of each color being refined further than what a human eye may see. Color spectrums that appear green, blue, indigos, and violets were not standard until the widespread adoption of eye augments. Additionally, infrared wave vibrations are perceived in a limited capacity. Specific artworks utilize this ability to vibrate waves uniquely, coupled with audio cues or jingles. Between their lively musical culture and vibrantly colored banners and tents, the nomadic tribes and colonies of the Avali can be vibrant places and are popular destinations among alien travelers adventurous enough to brave the hostile environment.

FOODS AND CULINARY

Avali differ from humans in many ways. One of the most significant differences is their diets based on obligate carnivorousness. Avali are biologically required to eat meat and animal products, like eggs. They are required to eat the entire animal to gain proper nutrition. This diet style has led to some interesting developments in their culinary practices. Cooking meats and other products can lead to the degradation or even destruction of specific critical vitamins and minerals, making consuming animals much safer but also less nutritious. Early Avali packs and tribes learned ways to get around this. While they are bound to a carnivorous lifestyle, cooking certain plants and fungi with their animals allows them to return these lost nutrients. Furthermore, Avali can consume these plants and fungus after cooking, as the act breaks down most of the materials. This



Figure 11 - Fungal plant known as "Kiri" yields a savory-flavored fruit. Fruits are used to supplement nutrition in food items like jerky and leather.

process allows for easier digestion through their systems.

As time progressed for Avali, tribes and colonies would develop large kitchens and eating areas. Specific packs would be assigned for bulk cooking. These packs would gather and prepare food sources and cook bulk meals for the community. While specific packs still maintained their own smaller kitchens for personal meals, the larger bulk kitchens took a lot of meal preparation stress from the pack while they performed other duties. Bulk kitchens also allowed hunter, foraging, and scout packs to stock up on meals before their responsibilities.

Avali developed a multitude of tools for preparing their prey for consumption. The diverse food selections required specialized tools, such as tools to break open hard chitin-like shells, gutting tools, and meat carvers—other tools allowed for the preservation of meals. Items like meat dryers and crystallizers preserve food for transport and storage. Meal preservation, like refrigeration and freezing, are done using frozen ammonia ice rather than water ice. Additionally, frozen methane crystals are also used to freeze meals for long periods of time. Certain crystals give off heat and are utilized for cooking foods in ovens, grills, or pots. Other forms of heat come from geothermal vents, which are used more for oven cooking. While the use of fire is limited,

some bulk kitchens have used fired ovens and cooking pits, thanks partly to its high heat output.

Stews are possibly the oldest meal made by the Avali tribes and remain common in modern times. Meats, bones, organs, and other ingredients are placed into pots of ammonia and cooked for extended periods. This method breaks down ingredients like bones and plants and allows for easier consumption. The softened bones are often eaten separately, during or after the meal. Avali would develop ways to transport prepared stews by creating sealable containers. Containers range in various sizes, from personal use to pack size. Freezing methods have also been found to be effective as well. The frozen stews are often reheated over heat crystals and are readied in a few minutes.

Leathers and jerky are also found to be another form of early meal preparation for Avali. While not as satisfying as stews, dried meats and certain leathers were consumed in moderate portions when environments proved too hostile to camp at or when performing duties in the field. Some dried meats are found to have certain seasonings added to them, to provide a bit of variety. Leathers, usually thicker hides of animals and devoid of fur, scales, or feathers, take well to sour fruits and would often be dried or prepped with them in mind. While most modern Avali considered these

items more of a snack food, their ancestors required them more for survival.

Desserts are more recent to the Avali food palette and



Figure 12 - Stringy fungal plant known as "Piru". The strands are harvested and ground into a flour-like substance, which is used to make a variety of goods.

differ from human desserts. While most humans find sweetened food to be dessert-like, Avali consider sour or extra-savory foods to be more desserts. Sweetness repulses most Avali. Most fruits on Avalon, for example, are often found to be sour or savory in flavor rather than sugary sweet. While most would consider early leathers a form of dessert, more recent additions to the Avali cuisines align more with humans as a form of dedicated dessert. Some would recognize a few styles, such as filled pastries, bread, and frozen creams. Others look odd, with gels and slimes often found in fruits. Some seem repulsive to humans, like meat gelatins and stuffed bones. However, these desserts are typical in modern Avali society. These meals' development coincided with the increase of living standards across Avalon. As Avali progressed and were no longer required to hunt daily for meals, desserts became more adopted across kitchens.

In more modern times, Avali have been able to process multiple food items to help sate their appetites. Their diets find new cuisines like tacos, pies, pizzas, and other entrees. While all are still heavily animal-based, processing specific plant and fungal materials have provided more variety to the average Avali diet. Avali have a response mechanism to spicy ingredients. Certain plants on Avalon offer the same effects as capsaicin on Earth, which has led Avali to spice some of their foods. Some packs often compete on spicy food intake. Bulk kitchens and community dining areas, alongside restaurants and cafes, are still



Figure 13 - Bioluminescent tree known as "Okaid Nakati" ('n' is silent). Its bark can be harvested for a spicy flavoring, and bioluminescent orbs can be boiled for concentrated vitamins.

heavily present in their societies. Pack kitchens and meals are standard, usually supplied with shelf-stable ingredients. Meat markets can be found across colonies and cities, allowing fresh ingredients to be obtained. Most of these markets come from local livestock farms, while others come from migrant tribes and usually have more exotic meats than farms.

Avali, over time, have developed certain herbal teas that offer stimulant, relaxation, and healing properties. These teas are made from plant and fungal leaves, fruits, and stems grounded into a fine powder and cooked in pots or kettles of ammonia. Depending on the combination, the effects of the tea will last between 1-10 hours. Stimulant teas offer a range of impacts, often found to enhance distance hearing, temperature regulation, or response time. The stimulant

times do not provide any sleeping deference, unlike some teas in human culture. The stimulant caffeine is highly toxic to Avali. Relaxation teas offer a combination of effects that decrease heart rate and blood pressure and activate sleeping responses in the brain. These teas are commonly served warm and last between 1-2 hours, long enough for an Avali to fall asleep. Healing teas offer a variety of vitamins that activate immediate healing responses in the Avali body. Most of these are used for digestive and feather health. Others are found to have hearing aid properties, often decreasing ringing in the ears due to high blood pressure or overexposure to loud sounds or electrical currents. Teas are still used frequently in modern Avali society. Human, or most other alien teas, are found to be toxic to Avali and are actively avoided.

Figure 14 - Avali enjoying a meal



AVALI LANGUAGE

Avali language is a very complex language. Thanks to their integration into the galactic scene, the language has been translated and simplified for other users. The development of the galactic language alongside the core language has created two separate but equally common languages for the Avali, the simplified galactic language, sometimes referred to as "Avali scratch," and the Avalian core language. All Avali speak the Avalian core language, and though its text looks like its galactic counterpart, the two do not operate similarly. Between the two, Avali scratch is more commonly seen by humans and in areas where cooperation colonies exist.

AVALI SCRATCH

The creation of the galactic language was in response to galactic integration. Written and adopted by the Illuminate, the Avali scratch language was intended to assist in translating the more common Galactic Common language. Although its intention was short-lived, the script and translations remained in use. The script allows certain alphabet letters to be associated with a close match of the core language. As such, the script is a near one-to-one copy of the Galactic common language, allowing Avali to read and understand things better. While not perfect, the translator allows for a rough understanding of what other Common speakers are saying. Additionally, the script is often used in mercantile fields, showing which shops or products are made for or by Avali. Avali scratch also contains no capital letters or specialty characters to simplify the language to galactic common further.

Avali, who intermingled with other races, often use the galactic version of the language to reduce confusion between their peers. Avali core is still spoken and written between other Avali members, however. Most Avali cannot speak Galactic common well, if at

all. Certain sounds, words, and cues do not translate well to Avali. Furthermore, certain sounds cannot be made by Avali due to their biological limitations. This limitation and a foreign environment have caused many translation issues when directly translating Avalian core. Other words must be broken down and learned to understand their meaning. In these cases, most words get assigned a close-enough equivalent. Specific Avali packs, such as ambassadors, dedicated a significant amount of time to learning Galactic common and are usually the closest an Avali can get to speak it. They are the sole translators at certain colonies or stations.

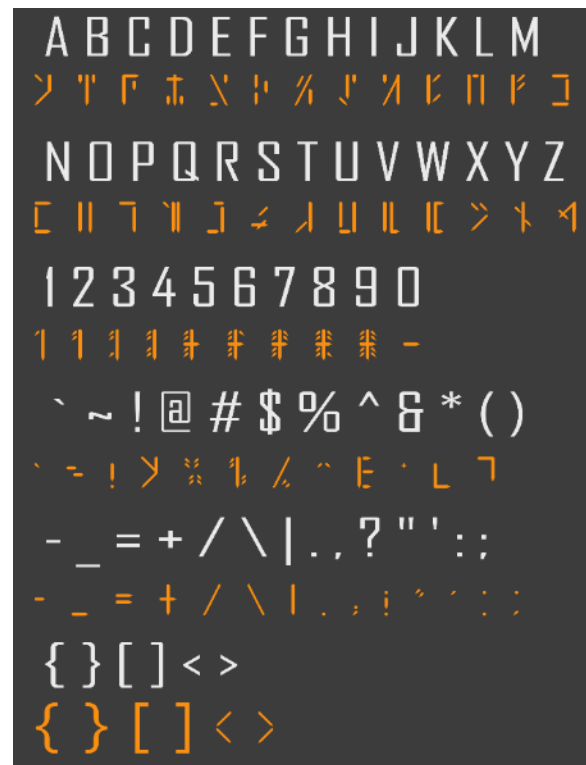

Figure 1 - Galactic Avali Scratch by SomeguynamedDavid and Icebelly

AVALIAN CORE LANGUAGE

While many languages are spoken on Avalon, adopting a central language was essential for standardized trading, sciences, and education. The adoption of the primary language happened after the rise of the

Illuminate. This primary language, "Avalian Core," takes many familiar cues, sounds, and mimics that most Avali use on Avalon. Dialects and accents exist in Avalian Core, universally recognized as the core language. Avalian core is a language filled with many sounds, most indicating words, and emotion. The structure of the Avalian core is not close to any Latin-based language found among humans. Avali can fluently speak the core language and a common territorial language. Traders often speak many languages due to their constant interaction with other territories.

Avalian core evolved as a sound-based language first, written second. As such, words contain short syllables, each containing a meaning. As such, some words are compounded, having descriptors, activity, or time stance. Reading back recorded words is equivalent to reading a piece of sheet music, as they are intended to be listened to, not read. To foreign audiences, the written characters of Avalian core look like pure scratches. They would need to learn many vital cues and emphasize to understand the structure of the reading material. While the language has been mostly translated into Galactic Common, some odd translation errors exist, with certain ones being ultimately named independently from the actual translation, an example being the moon "Queen's Pearl." Other translations have used a close approximation, though it might be different from what the word is. When translating between the two languages, the more descriptive and informative the source material is, the better.

The Avalian core does have a structure but can be challenging to identify at first glance. Avalian core can be written both vertically and horizontally. In both instances, reading occurs from left to right, like with human Latin languages. Vertical structures are written as official, non-emotion-based pieces. In the vertical instances, the words cascade downwards, with each syllable and respective modifier written out top-down. Sentences

occupy single columns and are spaced out. These include official reports, map records, educational and instructional material, and programming. Horizontal structures are casual, emotion-based, and much more common. This structure is mostly in line with common Latin languages, where an indicator separates sentences. However, the idea of paragraphs of sentences is treated differently. Each paragraph is a group of a particular subject, event, or instance. Paragraphs are filled with sentences that are separated by emotion or sentence modifier. While sentences are conjoined and separated by an indicator, these sentences are affected by a specific modifier or emotion. When switching these modifiers, or when stories, events, or moments change, a new sentence or string of sentences is created. It is common to see whole paragraphs where modifiers are repeated, adapting to what is written, or even whole paragraphs affected by a single modifier. Some examples of where horizontal structures are used are stories, letters, conversations, and poems.

Example of a horizontal paragraph:

Happy. Kaso received a new jacket today. She promptly wore it with glee. Her packmates love the new colors.

Indifferent. Kaso must consider what she wants to keep in her clothing collection. Her limit of 5 jackets has been exceeded.

Frustration. Kaso cannot decide on what to remove. Her packmates are not helping the situation. She is now thinking about sleeping it off.

Happy, relieved. She was able to find a space to carry her new jacket.

While speaking Avalian core, Avali will use sure sound bites, tones, or pitches while describing emotions. These sound modifiers are used at the beginning of the sentence or statements. If no special modifier is

spoken, the statement is assumed to be indifferent or not having any emotion necessary. Syllables are fine, sometimes even quick bites of sounds. They are also 1-3 established sounds, often rolled together for ease of speaking. These sound bites are represented in the form of a letter. Some syllables require modifiers to express the correct meaning. Syllables are essential, as each one is equated to a word. Not all syllables are single words, and many words require other syllables to rely on each other. These combinations can mean something completely different, unlike when they are alone. When written out, syllables are identifiable sounds with a marking that coincides with them. Up to 3 markings can be together, creating a syllable. Each has a particular identifier, such as a noun, adjective, adverb, etc.

Nouns can vary in subject matter and can be either immediately recognizable, a pronoun, or a catch-all noun, such as "thing." Like English, pronouns are only used once a definite subject has been identified. This includes animals, objects, and names. Gender-based pronouns do not exist. Commonly, when translating Avalian core to Galactic Common, translators' default to "they/them" for pronouns. Specific nouns have different pronouns, indicating the type, such as Avali, animals, and objects. Catch-all nouns are generic and can be applied to nearly all subjects. Often, these nouns are used due to the lack of knowledge of the subject and are not immediately recognizable. Some of these catch-all nouns can be confusing, as directly translated can mean prey, food, drink, thing, or thought. Other nouns can be seen as a catch-all but are descriptors of established nouns, such as friend, food, animal, and pet. Plural nouns are modified with an "sk" at the beginning of the word.

Adjectives are used before and after the described noun. Certain adjectives that describe sound resonance, vibration, and possession are always before the noun. Ones that describe

size, weight, and movement come after the noun. Possessive adjectives are always left out of the related word and will always be located before the noun. All other adjectives are compounded into the word if no more than three are used. Adjectives that are left out come after the described noun and are identified with an apostrophe-like indicator when written. Color descriptors, when written out, will always be separated with an apostrophe indicator. Color identification is always last and sometimes wholly omitted. Adjectives describing items far away or very dark are modified with an "s" at the beginning of the word. If the modified word is also affected by the plural sk-, the s will come after that modifier, creating an "sks-."

Verbs are treated differently depending on the style of the verb used. Passive verbs are combined with the affected noun if no more of the three adjectives have been added and will be at the end of the noun. Otherwise, passive verbs are added to the affected subject at the beginning of that word. Active verbs are not combined with any subject and are treated as their word. Adverbs only exist for action verbs and will be added at the beginning of the affected verb. Past tense and future tense verbs are also treated somewhat uniquely, with certain short sound pitches used to indicate the time signature of the verb or even the entire sentence. When written, these verbs are shown with a distinctive dash marking underneath the verb, or verb, and affected subject. All verbs are not tied to gender, like their pronoun counterparts.

Other vocal cues include quick pauses and clicks. Word fillers or pauses are heard when Avali are speaking and trying to fill the space with sound. These fillers or pauses come in the form of humming or clicking. Pauses are usually done for breathing, transitioning words or sentences, or constructing a response. When written out, required pauses are identified as a specialized apostrophe indicator within words. A specific sentence or paragraph modifier poses

a question, answers a question, or exclaims. Other modifiers are used when calling out or responding to commands. When quoting something, naming the person who said the quote could come before or after it, though it is generally called before. Speed and tone modifiers indicate how fast to speak a particular section, if needed, and how loud the speech is. No verbal cue is given for these, as is evident in the speed and volume when Avali are speaking.

Written commas are used frequently in Avalian core. For vertical and horizontal structures, commas are used when listing nouns in a sequence. This rule applies to all items. In horizontal structures, multiple verbs affecting a noun are also separated with commas. In vertical structures, extra adjectives, placed outside a noun modified with three adjectives, are divided with commas. Commas separate multiple packs or individual Avali in both formats. When referencing time instances, commas are not used, as verb modifiers are utilized for this purpose. When referencing places or creating prepositional phrases, commas are used only in horizontal structures. Prepositional phrases are separated with a specialty slash in vertical structures.

Written sentence modifiers fall under two distinct categories: emotional modifiers and general modifiers. Emotional modifiers are written out at the beginning of the sentence or paragraph. These emotions are portrayed, and the sentence's tone will adjust. For example, a happier sentence will sound brighter and fuller, whereas a sadder sentence will sound more bluesy and lower key. All common emotions are portrayed with a symbol. Some allow for the combination of emotional modifiers to exist, such as joyful and playful. Contradicting emotions, such as happiness and sadness, cannot be combined in one sentence. Certain emotions, such as indifference, apathy, and command, do not have a tone or symbol. The modifier key is blank, and the sentence or paragraph is monotoned. General modifiers are also situated at the beginning of the sentence,

after the emotional modifier. General modifiers alter the pace, volume, tone, and cadence and offer various speech patterns. These modifiers include things like questioning, exclamation, speed, and volume. These modifiers can also be seen in songs, sometimes used to distinguish certain regions of Avali, which speak differently from each other. General sentences that have no modifier are ended with a period-like symbol.

Capitalization of letters happens when changing sentences. Capitals are also used when identifying names, animals, and places. When capitalizing, only the first syllable gets capitalized, or the first character if the syllable has multiple sound bites attached. Capitalized letters are more generalized than their lowercase brethren. However, certain sounds have a true capitalization character attached due to their everyday use. All capital syllables or letters are not used and generally confuse when done. A modifier is used when writing out a yelling or heavily emphasized sentence.

Numbers are made on the base of 12. The number system starts at 1 and continues until 12. After 12, a special character is used to indicate a new series. As counting progresses, each series of 12 has a special character, until 12. After which, a new set of 12 is started, leaving the previous in line. This helps indicate how many hundreds, thousands, millions, etc. are counted. Each of these series of 12 is separated with a number specific comma. Decimals are represented in the same fashion, with each series representing tenths, hundredths, thousandths, etc. Like human arithmetic, decimal points indicate fractions, incomplete divisions, and so on. A special character 0 is used when indicating nothing. The number system can be written either vertically or horizontally.

Sound-wise, Avalian core uses a series of purrs, clicks, hisses, occasional popping, and hums. Rolling r's are frequent, and depending on the pitch or previous sound attachment,

they would mean different things. Some throat-growing noises also exist. Nearly all sounds emitted rely heavily on the manipulation of the tongue. This manipulation allows certain syllables to be appropriately announced and is crucial for forming certain words. Compared to humans, Avali do not have any sounds that rely on a nasal cavity since they do not have one. Certain sounds cannot be formed with their lips, as they do not have the very fine muscles needed to manipulate them in such a way. Compared to English, Avali cannot make sounds associated with f's, j's, n's, and v's. When translated, these characters will appear in Galactic common as an error. Proper translations for these characters are as follows: F's will be pronounced as "hthk", J's will be pronounced as "y-ah", V's will be pronounced as "bu", and N's are short pauses usually indicated as an apostrophe or a "ha" sound. For Avali, speaking and sound are essential, and incorrect pronunciation of certain words can lead to significant issues. Thankfully, humans are not expected to speak Avalian core, so Avali tend to be more patient around them.

Figure 2 - Capital letters

A	B	C	CHR	CHR~	D	E	ER
ER~	G	H	HSS	I	K	KR~	L
M	O	P	Q	QR~	R	R~	S
SS	SKA	T	U	W	X	Y	Z
ay	ah	ai	aw	be	bu	bw	bz
cak	caw	cee (ski)	ch	chr	chrr	cik	ckck
coo (purr)	dt	doo	eh	ee	er	err	eew
eep	eek	ga	geh	gee	gkk	grrk	ha
hthk	hsk	hss	hweh	ie	ieh	ka	kak
kja	kh	keee	kjrr	koo	krkr	kl	le
m	mm	o	oi	oo	pe	ph	qu
qh	qrr	r	rr	Rr	rR	rw	s
sh	sk	ska	sksk	ss	sy	th	the
tak	tic	ou	ur	wee	wh	x	yh
			yk	ze	zh		

Figure 3 - Lowercase Letters

Figure 4 – Symbols and Emotions

!	"(open)	#	\$	%	∞	Infinity	Divide
↓	>	#	✂	∞	∞	↓	∞
'	()	*	+	.		Sq Root	
<	[]	∞	∞	∞	∞	∞	∞
-	.	/	>	?	@	±	^
∞	∞	∞	∞	∞	∞	∞	∞
=	=/=	"(close)	:	:	{	}	Bit
'''	'''	∞	∞	∞	{	}	∞
<	`(click)	~ (purr)	[]	<=	>=	-
∞	∞	∞	[]	∞	∞	∞
\	Past tense	Future tense	Higher	Lower	Slower	Faster	PT long (o)
∞	∞	∞	∞	∞	∞	∞	∞
FT long (a)	Pause	Emphasis	Whisper	Trill	Number ,	Decimal	Curious
∞	∞	∞	∞	∞	∞	∞	∞
Happy	Sad	Vindictive	Angry	Frustrated	Depressed	Anxious	Joyful
∞	∞	∞	∞	∞	∞	∞	∞
Playful	Flirtatious	Love	Mating	Caring	Friendly	Threatening	Dismissive
∞	∞	∞	∞	∞	∞	∞	∞
Scoffing	Sleepy	Fatigued	Stressed	Bored	Grieving	Teasing	Hopefully
∞	∞	∞	∞	∞	∞	∞	∞
Rapidly	Slowly	Greeting	Sickly				
∞	∞	∞	∞				

(o) = Optional

Figure 5 – Number System

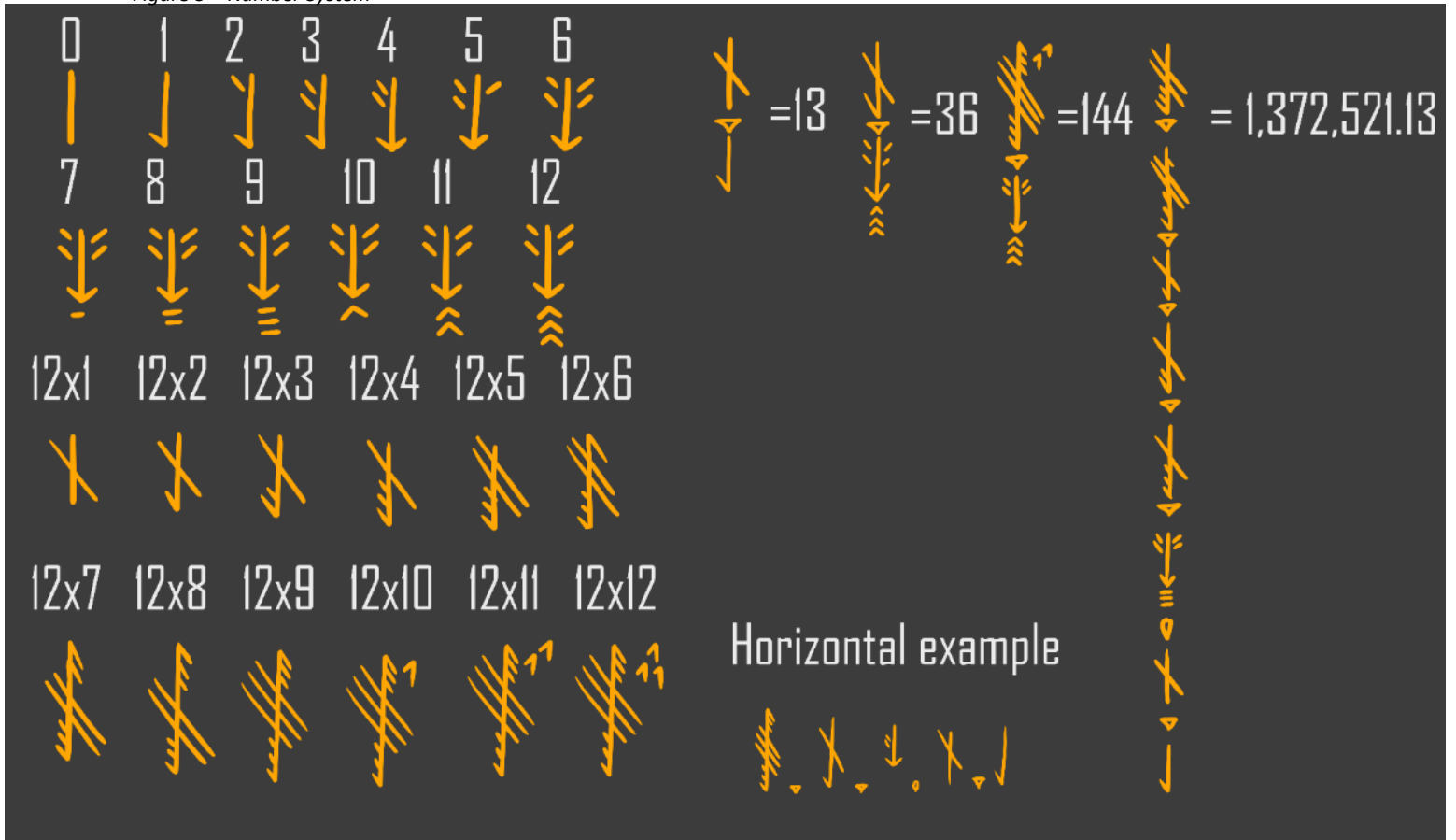

TECHNOLOGY

"It's hard to conceive such a race would evolve in such inhospitable conditions, let alone develop such advanced technologies. Yet, Avali have proven that nearly anything is possible" - UNoE Ambassador Josef Fuchs.

A defining characteristic of modern Avali life is technology. Avali have developed many technologies to adapt and progress them in their inhospitable home world and into the space age. While the initial development of these technologies was slow, they rapidly moved once they achieved a level of industrial-era-type technologies. Today, nearly every Avali relies on their technology to perform tasks and go about their daily lives. Even Avali outside of Avalon have their technology ingrained into their life, from body augments to virtual communication.

The primary source of nearly all modern Avali technology comes from the Illuminate. The faction is adept at developing new "cutting-edge" technology, all for the betterment of Avali's life. Outside of the Illuminate, Independent factions are found to develop in-house technologies alongside their Illuminate counterparts. Depending on the faction, tech can range from being a mirror of what the Illuminate creates, or drastically different for better adaptability in the environment or lifestyle.

CIVILIZATION WITHOUT FIRE

Avali evolved on an ice moon, and so did their societies. The use of fire was not prevalent, if used at all, as the heat source was deemed too extreme for use. Therefore, the adoption of the heat source happened further along in the civilization development cycle. Instead, Avali used heat crystals. These crystals have trapped iron and oxygen chemicals within a silica-based housing and, when disrupted,

cause an exothermic reaction, creating heat. The heat emitted from these crystals may not be as efficient as fire; however, the heat is enough to warm Avali on cold nights, and to boil ammonia or even water, when the right-sized crystals and settings are created. These crystals are easily identifiable by their orange color and the melted snow and ice around them. When not wholly active, they are safe for transport over long distances. Other crystals house bacteria that give off a glow when active, sometimes varying in colors, depending on which location of Avalon they were harvested from.

Mining or gathering these crystals requires knowledge and is usually left to designated Avali packs. While the crystals are a common sight on Avalon, extracting them without disrupting the contents requires some care. Avali would mine at the base of the crystal and collect the crystal fragments. Large crystals are used in furnaces and common areas, while smaller ones are dedicated for personal use. Once active, the crystal will glow a mild orange. The average lifespan of heat ranges from 2-8 hours for smaller crystals and several days for larger ones. The crystals are often used for cooking food, lighting tents and buildings, and basic chemistry. Once burnt out, the crystals are recycled into tools and decorations or broken down for use in artificial growing facilities. These crystals remain a common sight amongst Avali, as their mild heat and pleasant hues give a sense of coziness.

While heat crystals were used heavily in early Avali societies, they did not generate enough sustainable heat to melt metals. Most tools used by early Avali relied on crystals or sometimes ice to perform duties. The discovery of metallurgy would come with using another heat source, geothermal vents. The vents are found within the bedrock areas of Avalon. Since the crust of Avalon is thin, lava vents and tubes form within the mountains or some tundra fields. The first use of the vents can be traced back to cooking foods. Later, large stone ovens

would be made to create copper and iron tools. These geothermal vents would be the foundation of developing colonies and cities.

The introduction of steam-based machinery would come from these cities. This period of extensive steam adoption is seen as the early industrial age equivalent for Avali and would develop heavily into steam-powered technology. Most machines and buildings are sleek and refined, resembling what humans call "art deco," as Avali would hide many mechanized works behind sound panels. Avali will use the geothermal vents to boil and compress ammonia and water vapors to power machines that aid in mining and creating new tools. Later, steam refrigeration would become more commonplace in mines, allowing deeper exploration into previously unreachable areas. Some early colonies found Avali almost underground during this phase, as they turned heavily towards mining. As Avali dug deeper into Avalon, they would discover the vast ocean and its wildlife of amphibious lizards and fishes. Steam-powered vehicles became wildly adopted, as large boats and carts could carry much more food and resources. The wide adoption of these steam-powered vehicles saw the first adoption of fire for the first time.

Fire was seen as more of an asset than unwieldy during the steam era. Initial sources of fire came from lighting sticks and pieces of inert wood-like poles with flammable tips. These were placed near geothermal vents to create fire. Later, the development of flint ignitors became the mainstay for many generations. Burning flammable plants or fungal life was the primary source obtaining of fire. Coal was not found nor developed on Avalon. Instead, Avali would use a series of slow-burning plant fibers and specialty chemicals to generate high-heat fires. Fire's volatility on Avalon relegated it to specific use cases. Designated ovens and boilers are specially built to handle fires, locking the heat source to large steam vehicles, smelters, and kitchens. Geothermal vents are used to develop electricity generation. Large generators

were built underground and started to power the cities and colonies above.

In the modern Avali society, geothermal electricity generation is widespread, along with smelters and central heat pumps. The machinery used in modern societies is much more efficient and elegant than its predecessors. The use of fire has been relegated to some instances, such as off-site smelting and experimentation. Due to this limited use, fire remains a rare sight.

Crude hydrocarbon oil was discovered from mining deeper into the bedrock and under oceans during the industrial era. The oil deposits are created through the dying and compression of the wildlife in the subsurface oceans. Oil would float to certain parts of ice glaciers and often freeze within or around them. Some oil sources were buried in shale and other stony areas during mining, though reasonably scarce. Oil was initially dismissed by Avali, as they did not know what to do with the viscous substance until much later in their industrial age. The crude oil would be pumped and refined into fuels, plastics, and specialized chemicals. Oil refinement allowed for Avali machinery and vehicles to shrink in size. In addition, the refined fuels allowed Avali to begin the early stage of space exploration. Hydraulics were also developed and created with the cold environment in mind.

Compressed and frozen methane were discovered alongside oils. These materials are found along the ocean's lining of the bedrock and deep, heavy glaciers. Initially, these crystallized materials found a purpose in creating more heat in furnaces and boilers. During the early space age, the materials would boost fuel efficiency when leaving Avalon. Further developments would include new refrigeration gases, pneumatic machinery and tools. Avali would also begin harvesting comets and space debris from the rings of Elysium to maintain their frozen methane supplies.

AUGMENTS

As mentioned previously, Avali love to augment themselves. Augmentations date back to early tribal creations, with an example being the use of sight crystals to see prey. The addition of augments became more widespread during the mid to late industrial era. Rudimentary prosthetics gave way to more refined, hydraulic-assisted ones, with the medical field evolving to connect the brain to the machine. Other mild augments include feather dyes, feather styling, and claw coloring.

Modern Avali have some form of augments. Even during their embryonic stages, Avali genes are augmented slightly to mitigate congenital disabilities. By far, the most common augment Avali have been eye augments. Eyes are replaced with ones that can see farther, ultraviolet spectrums, and augmented reality with live data streams. Eyes can be stylized by colors and pseudo irises. Nearly equally as common is the Augmented Reality (AR) jack. AR is a technological alteration of the world through digital means, such as overlay, sounds, or digital objects. Located at the backside base of the Avali head, an AR jack is a computer port that connects an Avali to the Nexus Central network. These augments both directly connect and wirelessly connect to interface ports. The interface is generated through an embedded chipset, which connects directly to the eye receptors and hindbrain of the Avali. For Avali, who do not have these augments, visors are often used to augment reality and provide information. Other uses of visors can be seen in the operation of unpiloted vehicles, where an Avali can control or see a live feed of the drone vehicle.

Augments don't just stop at the eyes and brain. Avali utilize exoskeletons to assist in lifting large and cumbersome objects, enhancing speed, or surviving harsh environments. Temperature augments, which allow for sustained exposure to higher or lower

temperatures, can be seen on many Avali outside Avalon. These augments use a series of small, feather-shaped heat exchangers to maintain a core, conditioned temperature. These cooling lines interact directly with the blood and secondary lungs, cooling both parts and allowing for excess heat to be exhausted from the lungs. Usually, pressure augments are used alongside temperature augments to allow an Avali to have a slightly higher core temperature and survive in somewhat less dense atmospheres than Avalon's. These augments use pressure regulators across the body, mainly near the lungs and skull. Prosthetics have also evolved into more complex enhancements, though staying within their original intentions. Entirely replaced wing and tail feathers are seen, though not as

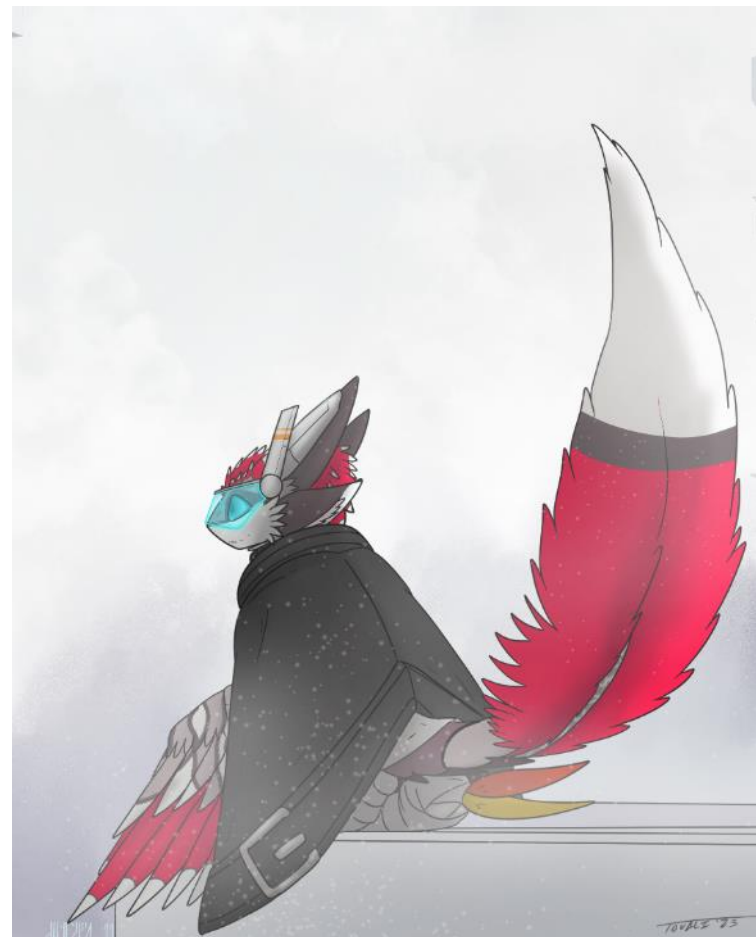

Figure 1 - Avali with drone controller and visor augments

expected.

Avali will be augmented in off-world environments to adjust comfortably to their new homes. Some of these augments can include feet and hand protection, changing out the paw pads, palms, and soles of their feet with more heat-resistant materials. In ambassador roles, Avali are known to augment themselves to be more in line with their alien cohorts. Ambassador Avali will often be seen with eye augments that offer white corneas, irises, and dark pupils. Female Avali will attach fake mammary glands to their chest to help distinguish them from males. This practice is usually only limited to ambassador roles, with rare instances outside of this being seen. Mammaries are seen as extremely odd and cumbersome for an Avali, and most shy away from getting the augment. Speech augments are also used to enhance and translate multiple languages, though they still require some speech training to learn the language. While ambassadors often use these, most other off-world Avali opt to use basic translators, as they tend to work just fine for their everyday lives.

Full-body cybernetic replacements are a rare and expensive form of augment. In this example, Avali brains are removed from their host body and implanted into an entirely cybernetic Avali shell. This dangerous operation requires many weeks or months of recovery, as the brain must reprogram itself for the new body. These cybernetic bodies house a nutrition and fluid pump to keep the brain alive and healthy. Additionally, filters are installed to remove toxins that accumulate in the body. Cybernetic bodies require continued maintenance, with nutrition fluids, oxygen, and filter replacements. These procedures are a one-time affair, as once the brain has been transferred to the cybernetic body, it will not be able to return to the original body without catastrophic issues. While Avali love to augment themselves, some find the complete cybernetic replacement too extreme. Career military packs are often seen with total

cybernetic replacements compared to all other packs.

Augmented Avali are much more capable of space exploration than their regular biology usually allows. Their advanced technology has allowed them to become more versatile than what their initial biological limitations can offer. The extensive range of augments allows Avali to change and adapt to many situations and personal preferences. Some augments, such as limb replacements, resist the hazards of hostile planets or space exposure. Some Avali augment themselves in ways that stray from their usual biological looks. While only a few instances exist, these Avali can change their entire body into another organic creature, taking on a new look and adaptation to the world. While these wild and fringe



Figure 2 – Avali with a partial wing replacement

cybernetic enhancements exist, Avali still need to undergo a thorough physical and psychological evaluation before electing to take the more extreme examples of augmentations. Despite the extensive technological progress, they are bound to their core chemical makeup. No augments exist to change this.

When undergoing augmentation, Avali are often suspended in a medical capsule, known as an augment vat, where their bodies undergo surgery. Medical vats are filled with a temperature-controlled ammonia-based liquid and are purified constantly to remove microbes and waste. They have a series of surgical machines mounted to the upper frame, where operations are performed on the body. Once

completed, a specialized steroid fluid is flushed through the vat to amplify the healing process. A dedicated medical pack will monitor the Avali during their time in the vat. Augments will be tested for functionality before releasing the Avali. If the augment fails, the member will undergo a correction surgery.

Organ augments are more natural than standard augments, using stem cells, DNA sequencing, and growth hormones to create the desired organ. Capsules are also used to grow natural organ augments. These organs are nearly identical to the recipient's body, making rejection of the organ rare. These organs are generally like their natural counterparts, with certain exceptions given to malformed or cancerous organs. While not as popular as a mechanical augment, the organs offer a more natural replacement for those Avali who prefer it.

CLOTHING

Clothing items developed late in Avali societies, compared to human societies. The concept of clothing was not a priority for most Avali, and some only wore a form of cladding to protect themselves from harsh storms. In tribes or colonies, leaders, hatchery workers, or guards usually wore clothing to signify their status. All other Avali usually wore utility gear for hunting, gathering, or other productive tasks. Additionally, sound-making garments or jewelry were also commonly worn amongst all Avali. As societies matured and cities were built, Avali would develop newer and more common articles of clothing for distinguishing different careers or for some form of artistic expression.

Early forms of Avali clothing were made of hides, chitin, furs, and feathers from hunted prey animals. Tribe leaders would wear garments that covered their upper chest and waist. Often, furs or feathers worn around the neck, tails, or on the head also signified pack or tribe leader statuses. Thick cloaks made from

leather were worn to weather harsh winds and snowfalls. Heavier cloaks offer fur or feather linings for insulation against colder regions of Avalon. Hatchery workers and guards are afforded some of the same garments as leaders, sometimes often decorated with multiple-pack jewels or insignias, to show neutrality. Sound-making jewelry or garments are made from harvested crystals or bones. Singing crystals, aptly named for their harmonics when exposed to specific vibrations, were attached to ears, tails, and wings for some form of individual expression. Other examples include stringing multiple crystals or bones together to make chimes, often hung off the body.

As Avali evolved on Avalon, they found new methods for making different clothing types. Fibers were discovered and harvested to fashion new clothing, eventually replacing hides for common Avali. Cotton-like fibers were later grown amongst tribes and colonies, creating new uniforms for packs and flags with symbols representing different civilizations. These fibers spurred the further development of traditional clothing articles such as skirts, sashes, jackets, and wraps. While leathers and furs fell out of favor, some areas of Avalon still use these items for their insulation properties. Fibers also allowed for the easier coloring of the clothing, paving the way for more intricate designs and various colors. While coloring clothing is nothing new, as leathers, furs, and feathers can be colored, fibers offer a more extensive range of colors to be created, from vibrant to dull. In the modern era, nearly every pack has a form of set colors and patterns they use to identify themselves.

Avali fashioned utility items since the dawn of their existence. Initially, bags and pouches made from hides and shells created a form of carrying goods across the frozen lands of Avalon. These items allowed Avali to stay migrant in the constantly changing world. They also provided a form of insulation for food items from the elements. Hunter packs often had multiple bags and pouches for harvesting their prey on the hunting grounds and returning to their nests or tribes. As time progressed, belts and pouches were commonly seen, allowing more items to be carried in the pack. Belts would often carry carving knives, ammunition for hunting weapons, and other items necessary for the hunt. Satchels are used

similarly; however, they have the added benefit of carrying food and hydration flasks. Holsters for spears, knives, and bows also started to become more widespread, freeing up the hands of Avali hunters. Before hatcheries were commonplace, fur egg carriers were used amongst packs and tribes, keeping eggs warm and transporting them to safe hatching areas. Some packs and tribes in regions of Avalon adopted eye blinders to protect their eyes from harsh rains and environments.

Footwear has become widely adopted in the modern era. Wraps or coverings were sometimes used to provide thermal protection or styling but never fully enclosed the foot.

Figure 3 - Examples of Avali Clothing

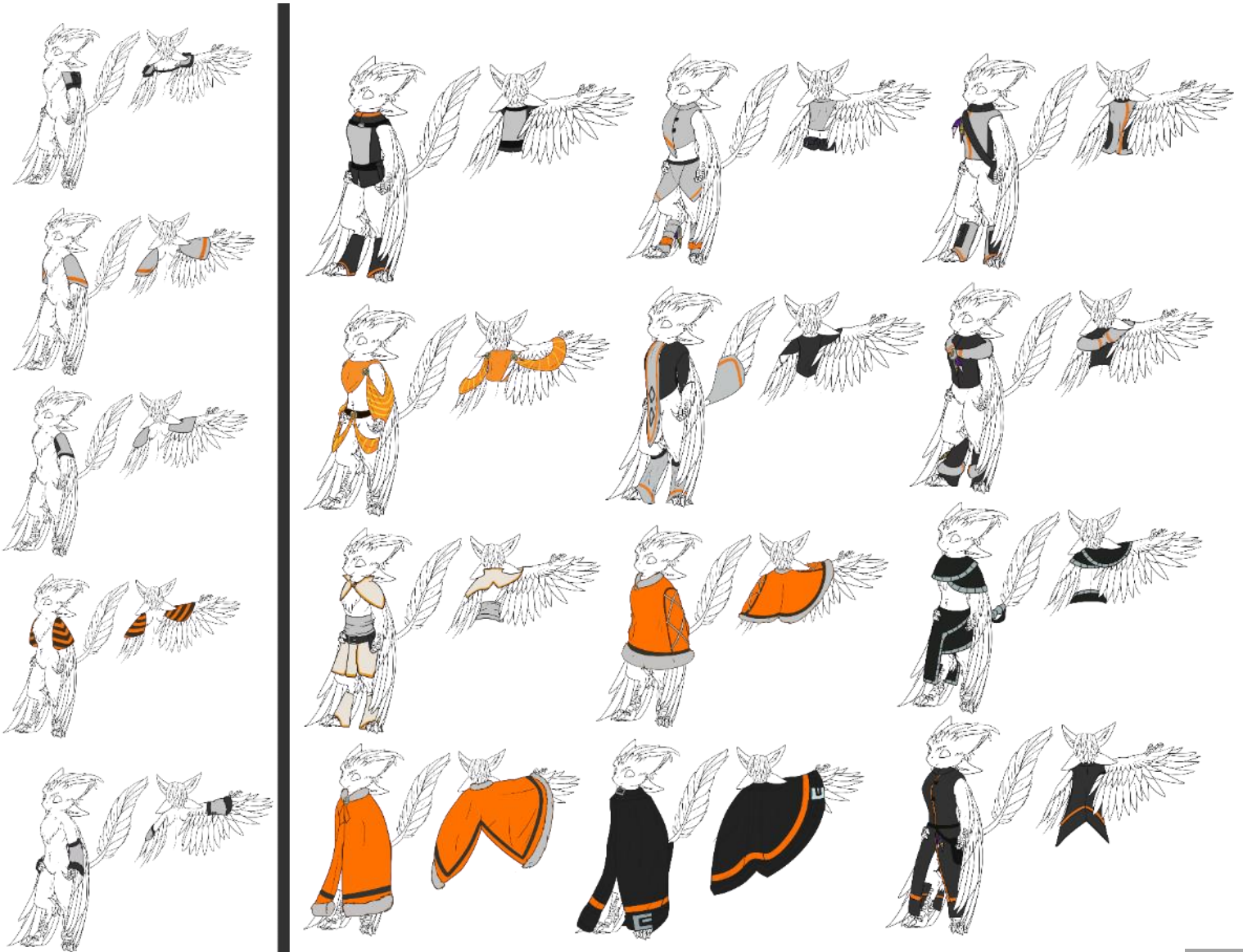

Modern Avali found utility boots covering the entire foot and ankle necessary for safety and industrial duties. Other fields, such as military units, have armored protection in this area. While footwear is more common than the previous generations of Avali, they are still not widespread outside exceptional use cases, and often Avali are seen without it.

Nano-canvas was developed to bridge the gap of the constant need for fibers and more robust materials. Nano-canvas is synthetically produced on a large industrial scale. The fabric is weaved at a nanometric scale, combining dense fibers and thin inert metal alloy wires. The result is a Kevlar-like material with excellent tensile strength and insulation while still lightweight. Freshly manufactured nano-canvas is white and somewhat plastic-looking in appearance. Often, the canvas is colored at the factory, even replacing the white base color with a more matte white finish. Nano-canvas has quickly been adopted across the Avali communities thanks to its resilience to weather environments and penetration durability. Nano-canvas developments also include electrical and communication conductivity to allow for easy attachment of electronics and interfaces. This conductivity made tents and migration less cumbersome, as the need for dedicated electrical interfaces was mostly eliminated. For space applications, nano-canvases have a protective layer to combat space hazards, made in graphene and often seen in black. Layers of nano-canvas can offer many benefits while still being flexible.

Operations in off-world areas have specially designed clothing to handle unique environments. Environment protection suits are designed to withstand the hardness of space and planet exploration. These suits are fabricated with a series of alloys and flexible nano-canvas to provide decent mobility and protection. Avali cannot fly naturally with these suits equipped. Compressed air booster packs allow Avali to reach higher locations to perform

duties. Some heavy articles of clothing are used to protect from heat and are used to preserve temperature. Other protective equipment includes coolant overlays. These heavy cloaks cover nearly the entire body of an Avali and have a hood, half-tail coverings, and wing coverings. They provide a series of recirculating cooling pipes to keep the member cool. These pipes are plumbed into an external pack, where a heat exchanger cools the refrigerant and pumps it back into the cloak. Additional parts can be attached to these cloaks to offer complete protection from the environment, including face masks, rebreathers, and specialty boots.

Avali are unable to wear pants due to their physiology. Instead, they wear skirts or pieces of clothing that interlock together. In interlocking pieces, clothing articles wrap around the legs, connecting to a central waist belt or skirt, and separate parts wrap around the waist, tail, and groin areas. In addition, the sleeves on their wings do not fully wrap around the whole wing. Instead, sleeves are held on through shoulder pieces, cuffs, or interlocking pieces that go between the feathers. Sometimes, sleeves cover the entire wing, offering protection from the elements.

DRONES AND VEHICLES

Avali developed an extensive range of vehicles to suit their needs. Early developments of vehicles included wheeled carts and sleds to haul tents and goods across Avalon. These were often powered by tamed animals that could also provide a source of food. Specific packs and tribes of Avali will develop rafts and small boats. As time progressed, vehicles for logistical needs would become more widespread. All early forms of vehicle development were necessary for migrating the pack or tribes across Avalon.

As Avali continued to develop, limited-use boats and ships were made to sail across the ammonia oceans. These ships were

constructed with hardened sterns to break through the ice and withstand becoming frozen at sea. Some tribes would sail seas for years, with large packs of ships, floating island glaciers, and megafauna as temporary homesteads and hatcheries. These packs would develop fishing techniques and be more resilient to water intake, as certain parts of Avalon's under-oceans become exposed during shelf movements. These tribes would begin trading with more land-based tribes and colonies, offering a unique set of food and supply options. Ships would become enormous, housing multiple packs, and be built by harvesting megafauna animal parts, floating plants, or fungus with dense stems and trunks. Later developments of ships would come in the form of metal alloy ships powered by steam. These ships were much more resilient to external forces, sailed faster, and could carry

large quantities of cargo.

In modern times, ships are still offered as a means of transportation and lifestyle on Avalon. Modern ships are powered with advanced fusion reactors and tidal and wind power. Ships can plow through shallow ice sheets and manipulate glaciers thanks to their robust power plants. While not as commonplace as they once were, ships and the tribes and packs associated with them are still seen today.

As some Avali embraced the sea, others found ways to navigate through them while still favoring the land or ice shelves. Additionally, since the landscape of Avalon can shift nearly overnight, Avali needed a safe place to rest for extended periods. Because of this, the development of Airboats became widespread. Airboats, boats propelled with forced air instead of water, gave the possibility of navigating oceans and ice shelves without needing two separate dedicated vehicles. The development of these boats did not start until the Industrial Era for Avali, as finding a reliable power source for propelling the ships was not possible until then. The adoption of steam power allowed airboats to be constructed and gave peace of mind to the migrant tribes and colonies. Large convoys of airboats started to sprout across the ice shelves and oceans alongside their standard migrant brethren. These boats, alongside their operators, tended to favor residing along the seas and ice shelves. In some dense fungal jungles on Avalon, smaller airboats were used to navigate the uncertain marshes and swamps. As the development of synthetic-type rubbers and fibers became available, airboats would find their general construction replaced with these instead of harvested plant and fungal materials. Adopting new materials allowed boats to become much lighter and faster. Today, airboats are powered through advanced solid-state batteries and recharged at designated ports during down times. Additionally, their construction has changed to favor nano-canvas and lightweight



Figure 4 – Avali operating a snowmobile-style utility vehicle to haul hunted prey. While rare, special individually-operated are used for utility purposes to assist packs and tribes. These vehicles are often seen clustered together to improve the efficiency of a pack.

alloys, allowing them to be more resistant to puncture and weather elements.

Land-based vehicles have been around for a long time for Avali. The wheel was developed early on in Avali society to use migrating packs and tribes across Avalon without losing supplies. Caravans of animal-drawn carts were once very common in the early days of Avalon. As the Industrial era took hold, steam-powered engines would start to haul large amounts of Avali goods and colonies across Avalon. Since the nature of their home world does not lend itself well to permanent structures, tracked trains are only partially adopted. Instead, trains and smaller vehicles carrying packs would be done with overland vehicles, and more in line with what humans might consider trucking convoys. However, rail-based trains would only be partially dismissed as cities based in bedrock areas of Avalon would

develop rail networks to streamline logistics to cities and source sites. That said, few rail systems are actively used on Avalon.

In most of the industrial era, except for prototype vehicles, personal-use vehicles were nearly nonexistent. All vehicles were designed with the pack in mind, at the minimum. In more modern times, personal use vehicles are still scarce, with limited use for short errand runs or emergency use. Some Avali packs opt out of using vehicles as they interfere with hunting activities. While a single Avali may pilot some vehicles, they're in constant contact with their pack or tribe and can even be assisted by AI. These remote pack members are often navigators and resource advisors who no longer need to be in the cabin of vehicles thanks to modern communication technologies.

Aircraft came about sporadically during the development of Avali societies. Developed early compared to humans, wooden and leather gliders would be used during some of the early days of societies, delivering food to distant colonies or tribes. During the Industrial Era, the use of aircraft fell out of favor. The development of steamships, overland vehicles, and airboats made gliders obsolete. Additionally, steam power did not lend itself to flight, as the machinery required to power a vehicle would have been too bulky. Hydrocarbon oils would instead bring new life back to aircraft, with oil-powered engines proving to be smaller and much more potent for airframes. The peak of aircraft development happened during the early space age, as aircraft became much lighter, more powerful, and faster. The height of the civil war would

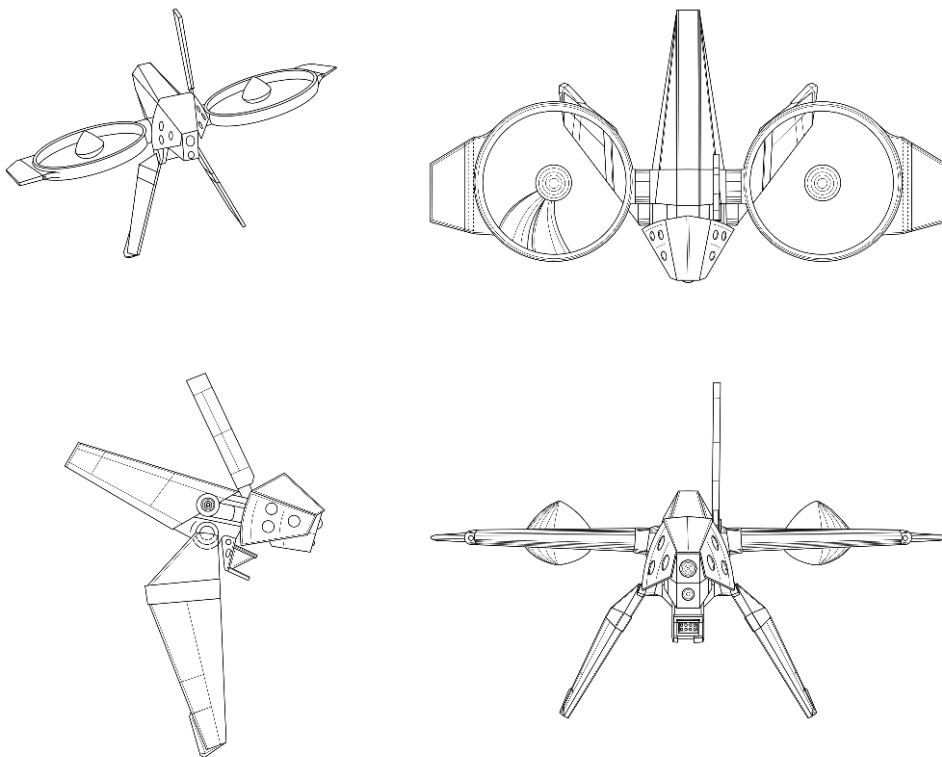

Figure 5 - Example of an Avali Drone



Figure 6 - Avali working on a drone.

see large aircraft carrying weapons and cargo across Avalon in mere hours. These aircraft ranged from jet-propelled fixed-winged airframes to small, maneuverable rotary-wing airframes. These vehicles became one of the mainstays of Avali societies. Aircraft would replace overland trains and ships for logistical and basic transportation needs. Small, pack-sized airframes would become widely used for hunting and foraging. The sizable fleets litter the sky of Avalon, though hard to see through the thick atmosphere.

Drones have become a staple of Avali society. Drones are remotely piloted machines, either through a series of programming or controlled remotely via a pilot. Early drone development began to assist hazardous mining operations as mining deeper into Avalon's crust became riskier. Drones would evolve outward to hunting scouts, supply vehicles, and even assisted farming. Drones, at their core, are not

very intelligent and rely heavily on computers and pilots to operate correctly. In modern times, Avali drones are used for nearly everything that once required hazardous manual labor. While certain skill sets remain and are trained constantly in AR, in case of drone failure, all dangerous duties have been eliminated from the Avali workforce in place of pilots, maintainers, and service operators. Other services use drones for scouting, supplying goods, and public transport.

Since Avali are very artistic, many drones and robots are constructed to express artistic creativity. Drones can be programmed to chime or play musical notes while performing tasks. Avali are known to take basic drones and augment them uniquely or experiment with ideas. Drones and robots modified to look more organic, with artificial feathers

and furs, are also seen.

MEDICAL NANITES

Nanomachines, referred to as "Guardian" nanites, are nanometric-sized machines developed for medical treatment. These machines are smaller than the average feather barb and coexist inside Avali for a short time. Common uses for nanites include repairing damaged tissues and cells, combating diseases, and altering genes during embryonic stages. These tiny machines do operations that would otherwise be too risky with standard surgical equipment. Nanites cannot wholly restore full functionality if the organ has been severely damaged or completely removed.

Nanites are simple by design. Nanites include basic navigational sensors, a small chipset for receiving radio command signals, a capacitor for energy, and some form of movement, like a tailor propeller. Nanites are constructed to be degradable, allowing for the natural processes of the Avali body to filter out dead or used nanites. Nanites are controlled via an implanted control chip in the skull of an Avali, usually integrated with the AR chipset. Avali, without such augments, will wear some form of a communicational array, such as a wristband or necklace. Nanites are deposited into the body through an ingestible pill or needle injection. In either case, nanites are placed in an energized gel to charge the tiny capacitors. In pill form, nanites enter the bloodstream through the upper stomach lining. Additional energy is captured through mild

electrical charges through neurons; however, this is not enough to fully charge a capacitor, only allowing for a gradual decline in power instead of an instant. They will then coexist within the blood for up to 2 weeks after ingestion; the bots are broken down and filtered out. The breakdown process is either done through general deterioration by interacting with cells or through new nanites in the system.

Nanites float around the body when inactive, usually attached to blood cells. Nanites become active when specific chemical triggers enter the bloodstream, such as activating biodefense mechanisms or platelet congestion. Biodefense information is translated to the nanites, which store data for combating diseases. Nanites hook together in long strands when healing a wound, allowing platelets to bond and seal the wound. More advanced nanites can slowly stitch wounds together, though these are often short-lived bots used in first-aid cases. The development of vaccines alongside nanites has essentially removed most, if not all, known diseases within Avali societies.

Nanites have also been critical in treating neurological and cancerous diseases. Thanks to their nanometric size, nanites can enter the neurological centers of Avali brains and nerves. Their small form factor has allowed for treating untreatable diseases or chemical imbalances. Additionally, specialty nanites can fix nerve damage by becoming strands of pseudo-nerve cells and allowing neurons' conductivity to pass. This unique use case is primarily seen in Avali, who suffered spinal injuries. Cancerous cells, in all stages, have also become easily treatable. Nanites can isolate and break apart cancer cells, filtering them out through natural processes.

Nanites do not provide extra pain tolerance to an Avali, nor do they enhance the strength of an Avali. Additionally, nanites do not change the chemical makeup of an Avali. They can provide needed chemicals or repair

Figure 7 - Examples of Medical nanites

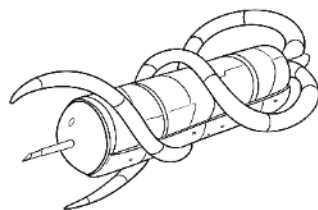

CAPSULE STYLE INJECTOR NANITE

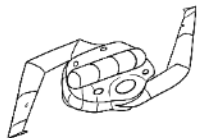

PLATELET STYLE NANITE

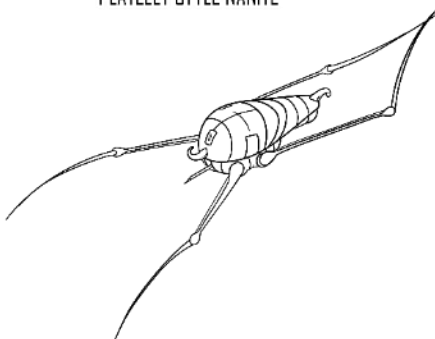

ADVANCED INJECTOR AND SEEKER NANITE

receptors of chemicals. Furthermore, nanites cannot regrow lost limbs or organs. They can expedite the healing and sanitize the affected area from bacteria. Limited cases are known for cognitive enhancement from nanites. More often, a dedicated augment will provide more for enhancing certain cognitive functions than nanites ever will. Nanites cannot stop injuries from impacts, penetration, or other possible forms of injury that can occur. Nanites are a medical tool to better the lives of all Avali. The Illuminate government outlaws weaponized nanites.

FARMING AND FOOD SUPPLY

Avali, being obligate carnivores, have struggled to maintain a stable food supply during the development of their societies. Many animals on Avalon have been exploited for their food and nourishment. Certain animals have found themselves domesticated by Avali for harvesting, hauling goods, and fur production. Some domesticated animals breed rapidly and die off quickly, allowing for quick replenishment of food supply in larger colonies. Larger-scale livestock production came in full swing during the Industrial Era when large breeder farms and butcheries populated the outskirts of cities and colonies. Due to limited space and growing populations, many cities would find themselves suffering through famines, forcing many Avali to return to hunter-tribes to survive.

The development of vertical livestock farms came late in the industrial era, as animals were placed in large, multilevel warehouses for food production. The creatures would be packed densely into these warehouses, allowing for some limited movement for muscle development and maximizing space utilization. Warehouses would vary in size based on the type of animal being raised and harvested. Hunters constantly brought ample supplies of prey back to colonies and cities, forcing much of the wildlife far away from more settled areas. This animal migration, in turn, limited hunting

to more migrant tribes and colonies. These migrant societies would also use regular livestock farming, as large stationary warehouses are not viable. Fishing for seafood in the ammonia oceans was limited to specific oceanic communities. Underground hunting and fishing became much more common in areas where mines developed into underground caverns. While much more dangerous, the undergrowth of Avalon provided much larger yields.

Capsule-grown meat and nutrition development, also known as "vat meat" or lab-grown meat, came during the early space age. Avali required specialized meals to maintain their bodies in space and high-altitude climates. Vat meats are created using isolated DNA strands to grow certain parts of an animal in a nutrient bath. Vat farms would soon replace large livestock farms and become one of the most consumed versions of food in Avali societies. Avali will still find themselves using regular livestock and hunting methods, for supplemental means, for eating more exotic foods, or for preference in taste. Vats can also be seen in various space colonies and stations, creating stable food supplies. Thanks to the developments of vat farming, Avalon's ecosystem recovered from the aggressive hunts and agriculture during the Industrial era.

Fishing farms also became more widespread during this era. Particular fish creatures could be bred rapidly in captivity, allowing for an additional food source. These fish are grown in large aquariums filled with either ammonia or water. This method permitted seafood to be raised and harvested more inland, away from ocean cities and colonies. In addition to fish, amphibious lizards and crawlers are grown on farms to diversify the food supply and ecosystem in the aquariums. The farms also had an equal impact on the ecology of Avalon as vats did, stabilizing the systems in the oceans. While aquariums are not often found outside Avalon, space colonies can obtain desired seafood through logistical

means. Fishing at sea remains popular for oceanic cities and colonies, though less aggressive than in previous generations.

Megafauna provides a significant source of food as well. Farming of these creatures has been done for many generations. Proper preparation of megafauna creatures can feed a whole tribe of Avali for weeks. The size of megafauna animals requires hunting packs to be out for days to hunt, kill, and return with their prey correctly. Improper hunting of megafauna is dangerous and often ends in the death of hunting packs. This danger is due to the prey falling after death, herds of creatures becoming startled, or highly aggressive creatures retaliating against attacks. Megafauna creatures are omnivores and can swallow an Avali with ease. Other megafauna creatures are more passive, with examples like large sea turtle-like creatures floating in oceans. These creatures would often have their shells broken open and slowly harvested. Another example of an animal exploited for its food is large, meandering carnivorous creatures dragging themselves across the ice shelves. These creatures, often identifiable by the large sacks on their backs, can generate large, regrowing flesh sacks that fall off over time. These large sacks, sometimes filled with eggs, are often eaten by these creatures or provide nutrition for their babies. Avali packs exploit these sacks as a food source, as a single sack can feed packs for days. Farming Megafauna creatures is not possible, as their sheer size and volatility create a danger for Avali colonies and cities.

Farming certain plants and fungi for consumption is done mainly in hydroponic basins. These bits of fauna are selected for their nutritional benefits and added to replenish lost nutrients after cooking animals. Avali would grow harvested seeds, plants, and other materials in designated pots

filled with nutrients. Pots were often transported by cart, allowing them to be easily transportable. During the development of cities, multilevel farms, like those seen in livestock warehouses, were made to grow larger quantities of plants and fungus at an industrial scale. Plant and fungal farms had a minor impact on Avalon, as Avali only consume these products for supplements. Aerogel and graphene-based hypotonic farms are much more common in today's societies. They take up small amounts of space and can rapidly grow plants and fungus through regular nutritional baths and growing optimizations, such as light levels. Farms can be found all over Avalon and beyond, growing products like Kiri, Piru, and Nataki.

ARCHITECTURE

Avali architecture is not as diverse as human architecture. Being nomadic, Avali were often stuck with designing tents, overhangs, and purpose-built wagons to live in and store their goods. While tent patterns can change between tribes and colonies, the general construction was all the same. Their constant movement across their moon and interactions with each other made diversifying their tents and architecture very challenging. When static buildings were finally formed during their Industrial revolution, they were constructed very utilitarianly. They were often squared off and angular. This style would remain relatively unchanged as they developed in and around the bedrock areas of their home world. Tents eventually moved from hides and foliage debris to strong, woven materials like canvas and thick sheets.



Figure 8 - Residential building



Hatcheries, often built on solid ground or in significantly stabilized locations, would be the exception to this rule. Although they varied wildly from location to location, they all followed a single theme: safety and security. These buildings are often built like fortresses. Hatcheries can either flow with the topology of the terrain or be dug deep into Avalon's crust. Hatcheries are uniform in a few critical ways. They offer medical services, recuperation/resting/sleeping areas, egg rooms, and guard rooms. Since hatcheries are built to be used by all members of Avali society, they will often be adorned with traditional-looking fabrics, adding tents and banners across the building. Guards will often live in these tents, protecting the building. Hatcheries would often find themselves at the center of many cities due to their tendency to be constructed on stable ground. Modern hatcheries, often found in more developed cities and off-world colonies, are built much more modularly. They often have a central cylinder-shaped core, with building "wings" surrounding it. Each wing houses a hatchery function, providing layers of protection to the core. These buildings continue the tradition of displaying multiple styles of banners and fabrics outside, indicating their neutrality.

Certain regions of Avalon developed their unique way of living using tents. In dense and extensive forests, Avali hung their tents within the trees, using the fauna to protect them from the elements. Some regions were

able to carve into the trees in which to live. Avali would use the branches to fly between tents. When it came time to move, the tents were dismantled and taken with the tribe. Excess materials were often left in the trees. Mountainous regions of Avalon found Avali developing landing centers for gliding aircraft and packs. Some tribes developed infrastructure within specific cave systems of the mountains to navigate through ranges quickly. These mountainous Avali would form colonies within these caves, with elaborate tents and dividers throughout the system.

The development of cities came late for Avali societies. Cities continue to be stylized in a very angular and practical way. Buildings are tall and sometimes narrow. They often have external landing areas for Avali to fly onto. Residential units are usually wide and frequently mimic tent-like structures. Modern buildings are modular and are built in sections. They also can be quickly dismantled and moved from place to place if needed. Windows are rare in these structures. While angular at first glance, every building is designed around sound, with holes, slants, and other little details that create passive sound resonance for Avali.

Today, Avali architecture designs have combined the tribal looks of canvas materials and chimes with their modern buildings' hard and sleek edges. Most Avali packs commonly utilize prefabricated boxes connected with tent pieces. Interiors are often decorated with sheets, banners, soft pillows, and hanging storage units. Lighting is usually dim and sparse. Chimes are still commonly used to convey shops and work centers externally. While buildings have become more uniform in color, sections of cities or buildings will have tribal colors located in marked territories. With the mass adoption of AR, many buildings and appliances have become barren in appearance, with AR filling the role of decoration through integration with

Figure 9 - Highrise of an Avali building. Note the platforms for flying in and out of the building.

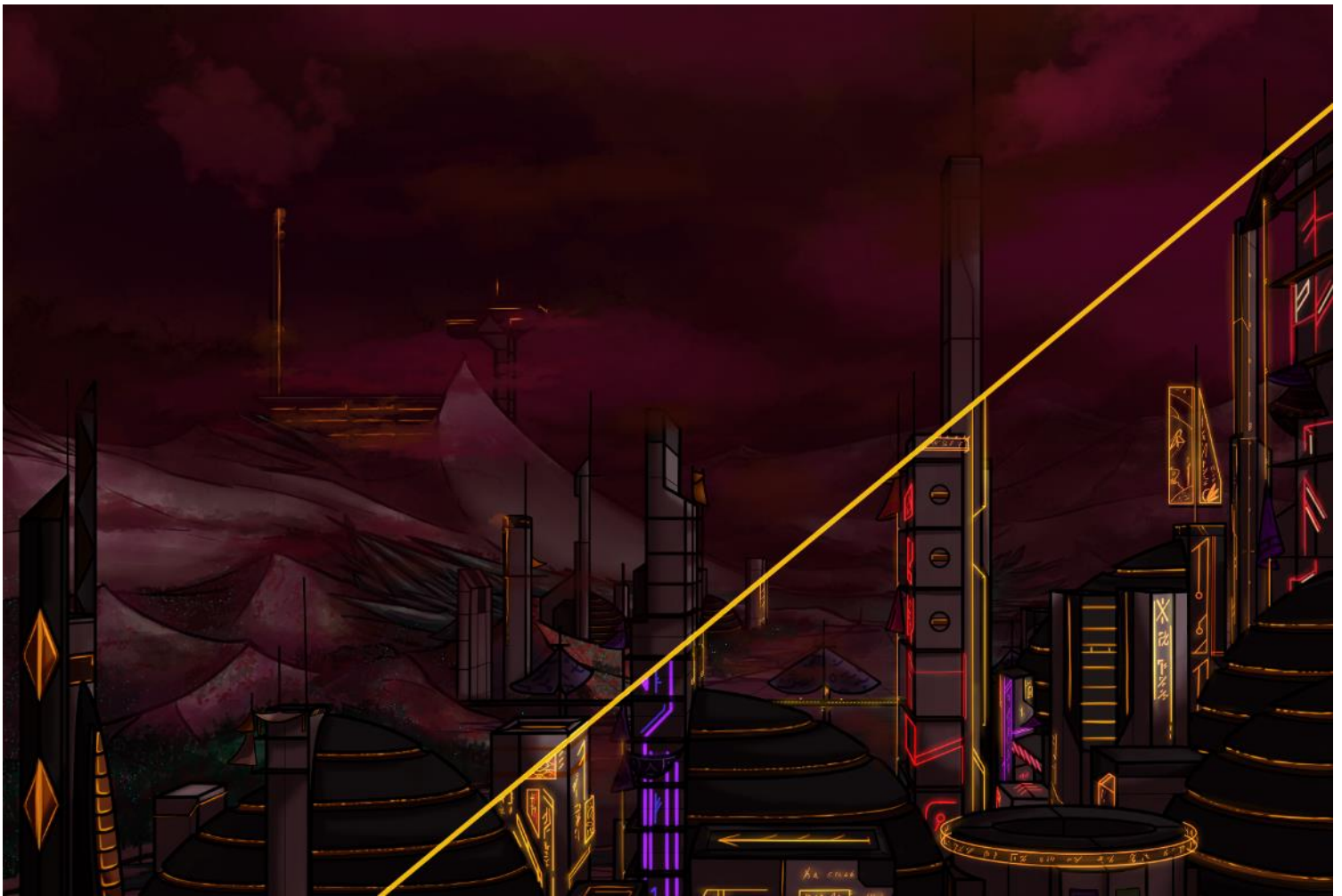

Figure 10 - Avalon Cityscape. Left side without augmented reality. Right side with Nexus Augmented Reality.

the Nexus. More on the Nexus will be discussed later in this section. User interfaces, information panels, advertisements, and other décor items are virtual and can only be seen with AR.

INFRASTRUCTURE

Unlike the sleek modern buildings found in most Avali cities developed much later in their society, navigational and seismic detection infrastructure has been a commonplace item since the beginning of civilization. Being nomadic, Avali could easily plan out routes and systems of migration and transportation to get around their home world. Tracking animals and finding secure places to sleep and rest were important and often a matter of life or death. They would turn to ways to help track and navigate the expanse of their moon with the use of roads, beacons, flags, chimes, and even more expensive projects like

bridges. In doing so, Avali were able to develop their society, securing their needs for housing, food, and hydration.

Roads and pathways are the oldest and most used infrastructure built by Avali. Secure and stable walking zones were plotted and shared by early Avali tribes. Places like these would offer a decent food supply and stable places to rest and recuperate. Roads and paths would be created by commonly crossed areas, soon developed into stone-laid or paved roads if the region was stable enough. These zones, however, would often disappear throughout the year. Avali would turn to other means of navigating across the moon. The use of beacons and flags replaced roads and paths. These beacons or flags would offer a general direction for Avali into commonly migrated areas. Flags would often fly the colors or banners of nearby tribes. In some regions, foliage markings and stones were used instead of flags. Some even

used fashioned ropes to help with navigation. Beacons, used later in their society, shined a dim light and were built on stable ground, offering shelter and food.

Buoy and seismic systems were also developed early on in society as well. Shifting ice shelves can happen at a moment's notice on Avalon. These would often be fatal to any Avali pack or tribe unprepared for the event. In turn, they developed ways to detect when these events can happen. Early systems were rudimentary, often consisting of a stick and a chime. The systems became more elaborate and in-depth as time progressed, while the concept remained somewhat the same. A chime or bell would sound off during the movement of the ice. These systems would also carry over to detecting volcanic activity. Cryovolcanoes can break through the ground, spewing water into unprepared tribes. Modern buoys have become much more durable, allowing them to float in the oceans and freeze during cold seasons. Buoys also became much more inclusive for detecting volcanic activities as well.

Mountainous, swampy, and heavily forested regions use bridges and tunnels to help with ground transport. These regions often have wildly varying terrain and fauna, necessitating these pieces of infrastructure. In addition, platforms can also be seen scattered across the land. These designated areas are built with the express purpose of flight. They offer a stable and safe landing and departure location for Avali. Some can be found outside these rugged regions; however, they are often exclusive to mountains and forest areas. While not as common, railway train systems were developed to transport goods and Avali rapidly between city colonies and outer tribes. Railways are built only on bedrock grounds, limiting their use.

In modern times, many of these infrastructure pieces have been thoroughly developed and implemented. Roads, walkways,

bridges, and the like are all built with high-strength materials, seen used daily and transporting millions upon millions of cargo pieces throughout their lifetime. Roads and beacons have been integrated into the Nexus AR system, allowing for clear overlays and navigation for Avali. Buoys have also been integrated into the system, offering real-time information alongside weather and forecasts. Flying platforms are still commonplace, even as drones and flight vehicles have taken over the skies.

OTHER ENGINEERING MARVELS

For many generations, Avali used crystals for a multitude of purposes. From windows to tools, crystals were grown and harvested from Avalon to fill these needs. A common source of crystalline material was liquid water. Since the surface of Avalon is well below the freezing point of water, refined water ice crystals were commonplace in the early moments of society. Silica crystals were also grown and would later be used more often during the Industrial era, as silica became more abundant and more heat resistant. Since growing crystals is a long process, other methods started to be experimented with, such as glass smelting. In more modern times, a newer invention has found a strong foothold in Avali societies, known as aerogel.

Aerogel is a lightweight crystalline structure filled with air. The most common variant of aerogel is ferrous aerogel, or simply orange aerogel. This structure is an iron-based, transparent crystal grown and chilled rapidly to the desired temperature, creating a stable and fine structure. The interior of the crystal is hollow due to the rapid expulsion of gasses during the refinement process. Aerogel can be 3-dimensionally (3D) printed through machines, thanks to a supply of compressed gasses and iron strands. Aerogel can be produced to an extraordinary fine point, giving it excellent cutting capabilities. While brittle, aerogel has

found a home in use cases like tools, displays, and weaponry. Other variants of aerogel include copper-, silicon-, and tungsten-based styles, all with unique colors. Aerogel can also be filled with a color hue to alter its appearance further.

Synthetic crystals are grown and have replaced their naturally occurring brethren in day-to-day use. These crystals are either grown or manufactured. When grown, specialized planters are used to create an optimal environment. These grown crystals can nearly replicate the crystalline structures found across Avalon. When manufactured, crystals often lose properties like heat generation. The crystal structure is left and can be further refined into necessary goods, like windows and visors. Manufacturing crystals happens much quicker than growing. The hardness and clarity of the crystals are preferred over aerogel.

Graphene and nanocarbons are strong materials that have become widely adopted, especially in space applications. Graphene is a single layer of carbon atoms bonded in a hexagon pattern to create a strong and flexible material. Avali use graphene to create lightweight space structures and protective space suits. The carbon properties of the material allow it to be inert to chemicals and resistant to heat. Additionally, graphene is used to create nanites, thanks to its atomic size. Graphene's use outside space exploration has been in military applications in armor creation. Nano carbons, particularly tubes of nanocarbons, are created from graphene and have a more dedicated role. These nanocarbon tubes are used to develop strong tensile wires, which are used for applications such as tents, elevator cables, safety restraints, and communication array restraints. Outside wires, the material is shaped into tubes to transport fluids of various temperatures in a tiny form factor while capable of withstanding varying pressures. Military applications of nanocarbons include the creation of projectiles, directional barrels, gun rails, and tracked vehicles. Both

materials are commonly 3D printed on the nanometric and atomic levels to their desired shape. Oversized products, such as space elevator cables, are woven in industrial looms.

Portable material printers for migrant colonies and space stations allow for the creation of new parts or materials on demand. These 3D printers range from handheld to larger workbench-sized machines with dedicated resource storage. Larger variants can store multiple types of materials and are much more capable of printing on an atomic scale. In contrast, handheld devices can print small parts or tools within a few minutes without leaving the worksite. Thanks to their versatility, these printers became more widely adopted across all fields. These printers cannot be constructed on an industrial scale, and more oversized items may take even hours or days to complete, depending on the complexity. In contrast, industrial printers can create multiple products at once within minutes or hours.

Portable data storage is found in small, aerogel "chiplets." These tiny devices encode data nano-metrically within the aerogel print. Chiplets also have a basic microprocessor in the housing for updating certain information, firmware, and communication with major networks, such as the Nexus. Chiplets can store many terabytes of data, thanks partly to nanometric encoding. When receiving the data, chiplets are inserted into specialized receptacles, where the data is scanned with fine lasers and uploaded onto the computer. These devices are used to call information, such as communicating with banks or government agencies. Chiplets are commonly seen as currency cards, where Avali use the devices to purchase and update their Lumes. The tiny microprocessors within the chiplet housing carry basic personal information that can be accessed via the Nexus network and is also used to project a display onto the aerogel for showing currency status. Other purposes for chiplets can be found in programming weapons, only allowing certain power levels to be active

and tying the weapon to the proper user. Avali will use chipllets to exchange data between computers and users when operating outside the Nexus network. Once the data is no longer needed, the aerogel print is destroyed and reprinted with new information. This process is usually done within dedicated recyclers or with specific receptacles capable of reprinting aerogel.

NEXUS CENTRAL NETWORK SYSTEM

The Nexus Central Network System, referred to as "Nexus," is a centralized collection of servers, computers, and interfaces that provide Avali with immediate information and data storage. The Nexus is integrated into nearly every aspect of an Avali's life, from currency transactions to essential communications. The system is interacted with via interface arrays, using AR, Virtual Reality (VR), or digital screen interface, though the latter is the least common and preferred way. Nearly all Avali use AR to interact with the Nexus via interface jacks in the backs of their heads or with visors. Nexus users and whole packs are often represented as digital avatars when interacting with the system.

Searching for information on Nexus is like how humans use the internet. Avali can browse, research, collect, and store information by looking at objects within their world and seeing associated information with those objects, such as materials, cost, pack information, and manufacturing data. Additionally, the Nexus can allow different browsing cities, colonies, shops, venues, and items by simply inputting the desired items. The Nexus can reconstruct and provide live data on cities, manufacturing, and transport vehicles. Information from the Nexus is delivered to all members interacting with the system instantaneously. The Nexus provides formulas, construction steps, schematics, and interactive 3D objects, used for training and learning skills and repairs. The Nexus is continuously updated

by its users. The system collects, sorts, stores, and disseminates information using elaborate algorithms. The Nexus operates outside Avalon as well, as new data from Avali explorers and alien race interactions update the system with more recent information. This constant flow of information allows the Nexus to store languages and provide real-time translations through AR.

Avali members create storefronts in the system, offering products in either physical or virtual areas. The most common offerings on the Nexus come from entertainment, artwork, training, and simulations. Other offerings include exotic literature from other races, alien products, and games. Avali can use Nexus's virtual reality capabilities for relaxation or practicing their skills in a safe, customizable environment. Furthermore, augmented environments are excellent places to meditate or practice hobbies.

Privacy is afforded to all individual or pack data banks. Each member or pack is encoded with encryption that only the augmented members can access. This level of encryption allows members to escape from the chaos of the Nexus privately and relax. Additionally, this prevents packs or members from being attacked maliciously in the Nexus. While constant monitoring is accomplished via AI, limits exist on what can be gathered for the Nexus data network and what is deemed private. The Nexus system is secured by ongoing encryption changes and limited access points, only allowing registered and augmented members access. Finally, the brain of an Avali cannot be digitally hacked into, further adding a layer of security to the system.

ORACLE AI ASSISTANT

The Oracle AI government assistant, referred to as "Oracle," is a system of prediction algorithms and statistics to aid in decision-making for the Illuminate. The system receives real-time data

from the Nexus system and a dedicated input system assigned to all industry forms. While both systems are often intertwined, Oracle's input system is much simpler and requires low bandwidth to submit data to the AI. The top Illuminate officials and leaders only use Oracle to calculate growth patterns, production quotas, and assignments for packs or tribes. Additionally, Oracle calculates output costs for industries that overproduce goods and assigns appropriate taxation brackets to return expenses to the Illuminate. This expenditure recuperation ensures that the Illuminate can payout and incentive awards.

The AI system constantly updates goals, quotas, and assignments as necessary. While most goals are often set at or around the beginning of each Avalon month, adjustments frequently happen due to unpredictable events or patterns. Illuminate leaders will review each

output before implementing it across their controlled areas. Another purpose for the Oracle system is to provide a standardized turn-over protocol and a history of all previous actions taken by the Illuminate. This protocol is necessary due to Illuminate leaders changing command every five years. Oracle also provides a series of checks and balances to ensure that favoritism is kept to a minimum. While not entirely perfect, the AI assistant has benefited the Illuminate, as governance of Avalon and its space colonies can be daunting.

Figure 11 - Avali hunters in a dark fungal swamp of Avalon





Figure 1 - Avali piloting an aircraft, flying above the tops of megafauna trees

MILITARY AND WEAPONRY

“Speak softly and carry a big stick; you will go far.” -United States’ 26th President Theodore Roosevelt, 1900

Concepts of standing fighting forces, defenses, and armaments have a complicated history within Avali societies. Compared to humans, the Avali race tends to be less aggressive against one another. Pack and tribe cohesion is the foundation of Avali culture; Avali are much more peaceful to one another, if at the bare minimum for survival. Although not actively combative against one another, periods in time on Avalon have found Avali fighting each other over resources, land, and fundamental rights. Additionally, and due to their hunting nature, some Avali also prey on one another to

gather resources, like food. In more modern times, a standing fighting force has been established to maintain the security and safety of the populace. Although not actively fighting wars or skirmishes, the military often conducts various training exercises to maintain skill sets. Skirmishes that happen are often due to Rogue tribes attacking others.

Weapons wielded by Avali forces are based on effective tools used in hunting and defense. Avali use a series of projective-based weaponry, like guns and sharp melee weapons, for closer encounters. Weapons trace their lineage back to early pack and tribal ages, where Avali would use simple sticks and rocks to obtain and process food. Avali weapons would follow in nearly the exact footsteps of human weapons technology, with very few instances of deviation. This technology has led

to familiar yet alien-looking weapons fielded by Avali forces. Vehicle-mounted weaponry is also very common within the military forces. Vehicles range from ground-based tracked and wheeled vehicles, mechanoids, warships, aircraft, and spacecraft. In the Illuminate inventory, aircraft and spacecraft tend to play a more significant role in mechanized weapons over all other fields. This prioritization does not entirely dismiss land and sea weapons, as their roles are still crucial to maintaining dominance.

MELEE WEAPONRY

Melee weapons come in many various forms. They are the earliest form of weapons developed by Avali. Early melee weapons included spears and carving knives specially designed to hunt and process prey. Weapons are often fashioned from sturdy sticks and crystals or sharpened stones. Hunting packs would often carry multiple spears, capable of being thrown or jabbed into animals. It is common to see every Avali have some form of knife. Knives varied in length and were often specialized for processing prey animals. Some blades were cutlass or sword length, used for carving megafauna. Large, curved scythes are often used for collecting fur, opening chitin, or cutting away overgrowth. As technology progressed, the blades or tips of these weapons would be replaced with metals and alloys, increasing their durability over crystal ones. Plant fiber poles would be replaced by metal or plastics.

Modern melee weapons are made with aerogel, nanocarbons, and alloys. These weapons are still commonplace in hunting and military applications. Specific hunting packs prefer the stealth aspect of melee weapons over projectile ones. In military applications, melee weapons are used at close and short ranges and generally are knives, swords, and spears. In addition, military melee weapons are more advanced than hunter ones. Military variants are small, battery-powered printers

that produce a sharp, nanometer-thin aerogel blade in minutes. These blades are brittle and often break off inside targets. The printers will replenish the edge if material and battery power are present. Blades often have high-frequency oscillators, creating a repetitional sawing action, causing more injury to the inflicted target. These melee weapons are issued to troops without sheaths, as the blades can be fully ejected from the weapon, usually into a designated dumping pouch. Hunter melee weapons are built out of nanocarbons and alloys, remaining sharp and robust after each use. While not as advanced, hunters prefer the reusability of blades over replenishing ones, as digging sharp shards of aerogel out of meat is not fun.

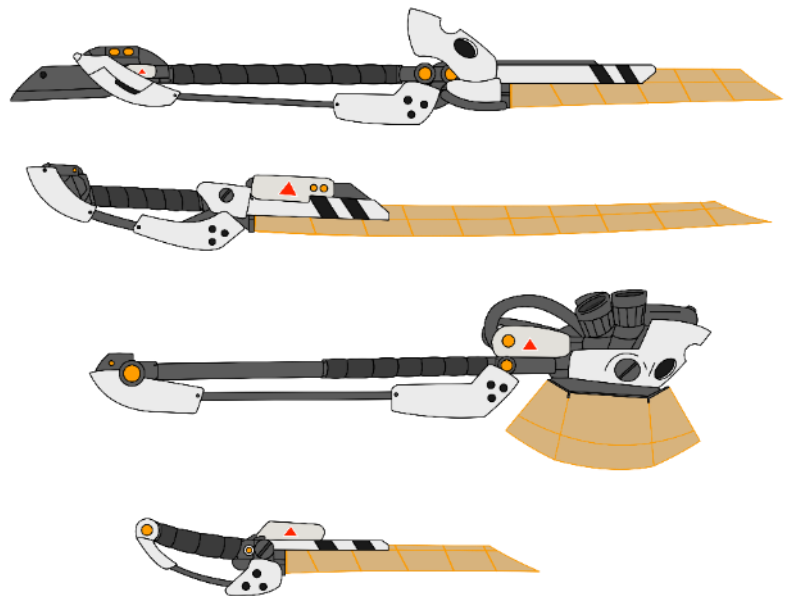

Figure 2 - Examples of Avali Melee weaponry

General purpose tools share some of the same qualities afforded to weapons. Axes, ground plows, and picks have benefitted from the creation of replenishing aerogel blades or durable nanocarbon blades and handles. Tools have become extremely lightweight in comparison to their metal and alloy ancestors. Extremely fine points on tools and gyroscopic stabilizers allow for precision repairs that would otherwise be impossible. Tool schematics

retrieved from the Nexus allow Avali to 3D print tools as needed. Tools are capable of being recycled into raw materials through designated machines.

RANGED WEAPONRY

Ranged weaponry traces its roots to bows and arrows and thrown spears. Bows and arrows found prominence to hunt fast-moving prey and protect Avali packs from predators that populate the land and sky. Specialized portable spear launchers, equivalent to a ballista, were made to hunt larger prey animals, like megafauna. Bows would later evolve into chemically propelled projectiles, a form of early muskets and cannons. These weapons would propel crystal, and later metal, projectiles into targets. Crystal projectiles often fragment and inflict more damage on softer targets but are relatively ineffective against more rigid or resilient targets. Metal, mainly copper, would become the preferred method and shape into what would be seen as bullets. The Industrial era would dawn encased, self-contained cartridges and weapons to match. Guns would evolve into repeaters, along with proper rifling of barrels. The development of sound suppressors was much quicker than with humans, as the loud crack of a gun was deafening to Avali. Nearly all handheld weapons came standard with some form of sound-deadening device. Other weapons would adopt specialized ammunition, unable to crack the sound barrier, but still, inflict respectable damage to their targets. Cannons would not see the same sound suppressant capabilities however would still evolve the same way as handheld guns. Artillery would be constructed as lightweight as possible until the broad adoption of mechanized vehicles.

Today, modern Avali guns are gauss and magnetic-drive rail weapons. The advent of solid-state batteries allowed decent power to be portable and power these devices without needing constant recharging. Projectiles have

evolved into flechette and dowl style rounds, constructed from either nanocarbons or iron-wrapped tungsten. Handheld guns are gauss-based weapons, using a series of capacitors and magnetic coils to propel rounds to their desired target. These weapons are also augmented to fit the Avali, only activating when the member chooses so. Live data is transmitted to augmented eyes or visors, showing the target, range, estimated trajectory through a crosshair, and ammunition count. These augments rely on a sensor array, usually located at the top of the gun. Larger, telescopic arrays are seen on guns built for longer-range shooting. Gauss weapons rely on magazines of magnetic rounds and batteries to function correctly. Common weapon systems include short-range defensive, medium-range select-fire, and long-range precision guns. Pistols are still seen in cartridge-based forms, as gauss propulsion is not viable in such a small form factor.

Railguns are like gauss weapons but use drivers to push a projectile forward rather than pull. Railguns replaced cannons and artillery in their roles in the Avali military. Large railguns can be seen on wheeled and tracked land vehicles, mechanoids, and ships in all fields. Railguns are required to be a relatively large size to be appropriately effective. These guns launch nanocarbon or solid tungsten flechettes and sabots at hypersonic speeds. Magazines of these rounds feed the weapon. The massive force of energy through a railgun requires the rails to be thermally cooled and replaced frequently to maintain accuracy and effectiveness. The impact of a railgun's projectile can be explosive, depending on the conditions, due to the massive amount of energy placed on the target. Tungsten rounds are effective at penetrating thick armor plates or emplaced bunkers. In contrast, nanocarbon rounds have less wear on the rails and fly faster to their target, creating an impact blast once contact is made.

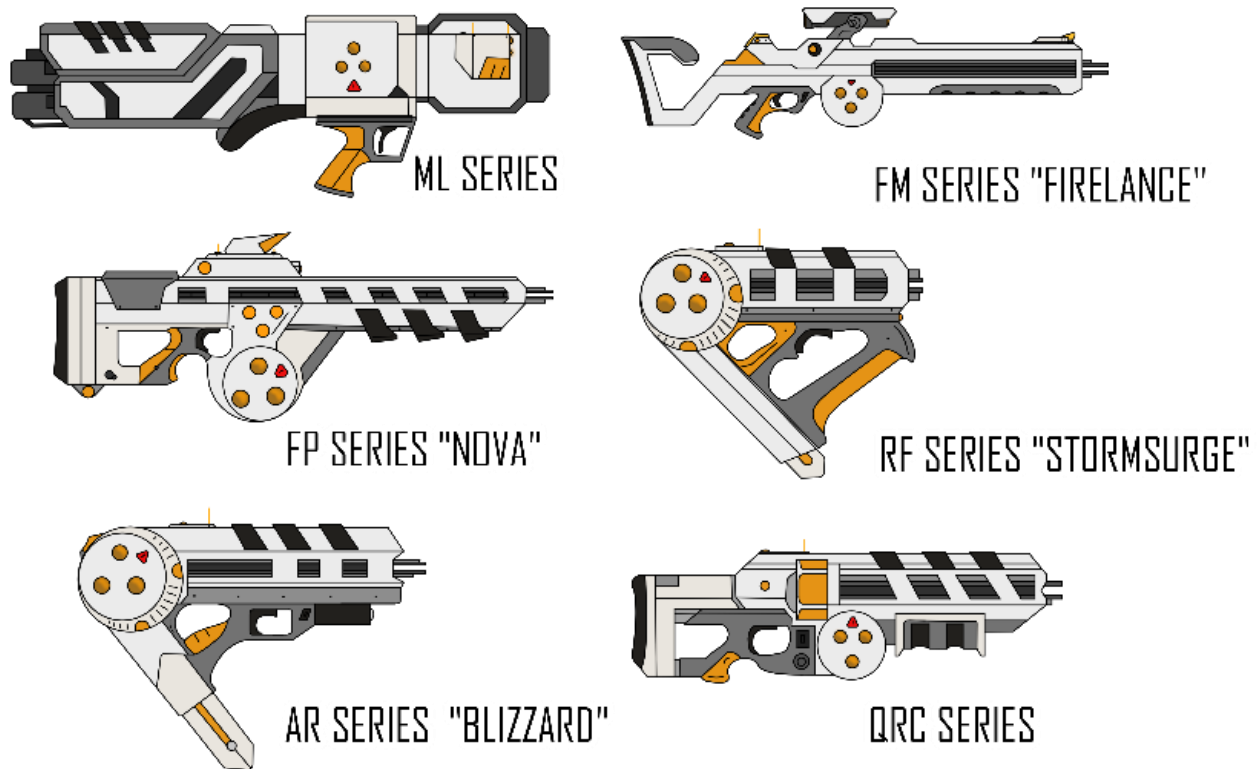

Figure 3 - Examples of Avali ranged weaponry

Bombs and missiles were used extensively during industrial era wars, often collapsing whole colonies and cities into the oceans. Explosives, bombs, and missiles are also significantly used in military applications. Avali bombs are more than just crude tubes with explosives packed within; bombs are programmed and detonated on their desired target. Their high explosive yield makes them favorable for bunker busting, precision building detonation, and tunnel clearing. Bombs have multiple variants that include guided mortars, cluster bombs, and heavy-yield variants.

In contrast, missiles are lower-yield explosives capable of traveling at hypersonic speeds. Missiles are excellent at intercepting moving targets such as aircraft and spacecraft. Missiles are equally as smart as their bomb counterparts, capable of being programmed and launched onto designated targets. Most Avali mechanized forces use some form of missile array system as a defensive measure

against aircraft and spacecraft, in addition to camouflaging smoke and bombs.

MILITARY DRONES

Combat drones are produced cheaply and en masse to fill direct combat roles in the military. These drones are lightly armored and have simplistic AI software capable of basic navigation and target acquisition. They require an Avali pilot to give commands, such as navigation direction and target engagement. They are small, nimble, and fast, capable of carrying short to medium-range weapons and necessary ammunition. The battery life of these drones is short, lasting about a day of full-time use. Combat drones are also used for scouting and marking areas of operation, plus relaying targets' positions and points of interest data back to Avali troops.

Larger vehicle drones are built to withstand direct attacks while being somewhat mobile. These vehicles are often used as mobile

artillery and anti-aircraft or anti-spacecraft roles. They still require a remote pilot to operate the vehicle for navigation and target engagement. While still needing a pilot, the AI tends to be more sophisticated and capable of disengagement and defensive measures when threatened. Additionally, vehicles can move short distances to avoid environmental hazards. The power plants on these drones vary, depending on the application, ranging from large batteries to small fission reactors to maintain power. Generally, railgun-based weapons are often seen with fission reactors, whereas missiles, artillery, and gauss cannons are seen with solid-state batteries, capable of lasting days on a single charge.

Scouting and supply ground vehicles are also frequently used, moving requested materials directly to the requested area of operation. These vehicles are possibly one of the more sophisticated variants employed by the military. They are nearly autonomous, only requiring simple commands from the users. Drones are fed real-time data from combat drones and other scouting units to navigate the battlefield with troops. They are small, usually wheeled-based vehicles capable of carrying weapons, ammunition, and support supplies with the soldiers. During engagements, they will either hide or provide a mobile barrier to protect the troops. Additionally, drones have the option to be directly controlled, and thanks to their relatively small size and sturdy construction, they can easily navigate buildings and tight quarters. They cannot engage targets and are primarily made for logistical support.

In space, drone fighters and corvettes are used extensively, eliminating the need for direct pilot control of these vehicles. These vessels can withstand large amounts of gravitational stress, as the lack of crew allows for much more aggressive maneuvering without fear of safety. They are also very costly to produce. Drone armament varies depending on the design, though commonly, fighters carry a pair of rail or gauss cannons and an assortment

of missiles. Corvettes have large rail cannons, guided bombs, and hypersonic missiles. Fighter drones will often remain attached to a central destroyer class or cruiser class ship until deployment is needed. Corvettes will operate at near full-time readiness, only pausing for maintenance, and are usually operated from a cruiser class ship. Thanks to their readiness, corvettes are capable of first engagement protocols and scouting and charting the star system.

ARMORS AND EQUIPMENT

Standard issue power armor and exoskeletons are the norms in Avali military frontline forces. Armor is made from tungsten and nanocarbons, protecting from projectiles and the environment. Power armors are usually attached to exoskeletons, providing plating and cargo storage pouches. Special temperature suits are worn when using these armors to maintain a core



Figure 4 - Standard issue armor

temperature for the user. Power armor relies on batteries located on the backside plate. Armors also interface with augments, providing data. Standard issue armor covers most of the body, leaving the tail exposed, though tail guards can be attached. Wing guards are also issued and are optional to wear. Power armor helmets are completely enclosed affairs, covering the eyes, mouth, and much of the head. Ear relief holes are used, along with augments attached to the ears, for concussive blast protection.

Scout armors are lighter and more flexible but offer less protection. Often built from nanocarbons and nano-canvas, scout armors can camouflage easier with the environment, giving off little heat signatures.

Scout armors are attached to exoskeletons the same way as full-power armors but offer longer battery life due to their lighter weight. The armor covers most of the body, exposing the wings and tail. Scout helmets shroud most of the head but are much more identifiable with a synthetic crystal visor and, thus, lighter. Generally, scout helmets do not offer specialized ear protection unless needed for their operation. Scout armors, despite their name, are also used by logistical, communications, and command troops.

Specialty armor is used for more elite forces. Elite forces often have purpose-built armor for their missions. Depending on the task, these armors are built off the same exoskeleton platforms but use much more varied materials. Specialty armors often cover the entire body, making identifying individual Avali extremely difficult. Helmets can either have crystal visors or no visors at all. Due to their nature, specialty armors are very expensive and complex, some even housing deployable melee weapons in the armor plates. Other armor builds are tank-like, capable of withstanding multiple hits and plowing through buildings. Outside of military use, hatchery guards are also seen wearing this armor variant, some with decorated helmets.



Figure 5 - Specialty Armor, one equipped with a synthetic crystal visor (left), and no visor (right).

and a light blue indicating air forces. Space fleets are given a purple uniform. Specific career fields will receive exosuits to assist with accomplishing duties, such as logistical troops. Maintenance fields will often be seen in solid black or blue aprons or protective garments when working. The utility uniform does not provide headgear. When deploying, support troops will be issued a variant of the scout armor, with a chest plate, helmet, and lower leg protection. This armor is worn in conjunction with the standard utility uniform.



Figure 6 - Example of the standard military uniform for Space troops

Avali troops who do not operate on the frontline, known as non-combat troops or support troops, will receive a standard issue utility uniform. Utility uniforms are color coded to each operational branch of the military. Ground troops are issued a light grey and orange uniform. Naval and air troops are issued a dark blue utility uniform, with a light green stripe indicating naval forces

Avali are issued a standard assortment of gear for military duties. Cargo pouches, multifunction tools, rebreathers, and aerogel blades are some of the standard issue equipment for all troops. Frontline troops are issued a select-fire gauss gun, equivalent to an assault rifle, capable of engaging targets at short to medium ranges. They are also given a secondary ranged weapon of choice, either multi-shot, like shotguns, long-range precision guns, short-range pistols, or auto guns. Troops



Figure 7 - Example of the standard military uniform for Ground troops

can exchange melee weapons for something different based on personal preference. Additional gear includes ready-to-eat meals, hydration flasks, portable computers, communication tablets, ammunition, deployable camouflage coverings, and spare batteries. Special units optimize what items to take for their missions and often forgo standard-issue equipment in favor of other equipment.

Camouflaged equipment and armor pieces are standard. For Avali personal armor, the parts are designed in such a way as to mitigate sound and thermal signatures. The traditional colors for armor are usually a series of grays, sometimes oriented to reduce signatures. Blending colors with the environment, like those seen with many human armed forces, is not heavily used, reserved for only specialized units and large equipment. Equipment will have a covering fabric printed to match the environment when used. Coverings are removable after operations and are usually recycled for materials. Painting equipment and personal armor is rare and often discouraged, as paint can disturb thermal and sound coatings.

MILITARY VEHICLES

Avali utilize an extensive range of vehicles in all fields of warfare. Most vehicles are designed to be light, maneuverable, and quick to match the methods of war exercised by Avali forces. The Avali armory uses specialty equipment for air, space, and ground vehicles. Sea vehicles have become nearly nonexistent, except for small infiltration craft. Only a handful of vehicles are heavy and tank-like.

Land vehicles are varied in their roles, and come in wheeled, tracked, and mechanoid variants. Wheeled vehicles are either large support vehicles or small frontline vehicles. The larger support vehicles sustain the frontline forces while offering communication and infield

medical attention. Other large vehicles are seen as artillery or anti-air and anti-space batteries. Light and medium-duty tank vehicles exist within the Avali arsenal, though their roles often differ from how humans view tanks. Tanks are small and wide, with their low profile used to hide. Tanks are used in a medium to long-range suppressive role, or to engage in emplaced bunkers and bases, then rapidly retreat. The armor on the tank is only designed to take small arms, low to medium-yield explosives, and small caliber cannon shots. Medium tanks are often used for luring enemies or engagement of lightweight vehicles, as their heavier armor deflects most attacks. Light tanks are used extensively for low-profile, strafing fires. These tanks often have an autocannon capable of firing 100-250 rounds on target within a minute. Mechanoid forces have supplemented anti-tank roles. For a pack's rapid mobility, small tactical vehicles are used for quick engagements, creating traps and ambushes, and performing scouting duties. These small, pack-sized vehicles are meant for rapid infiltration and exfiltration, causing chaos against enemy forces. These small tactical vehicles often have automatic gauss guns or small missiles for engagements.

Mechanoids, shortened to "mechs," are vehicles with the capability to walk on mechanical legs, usually through hydraulics and electric motors. These vehicles are large in their profile but are used extensively for their mobility in unpredictable landscapes and ability to engage targets at long range. Mechs will carry a series of rail guns and missile arrays on their bodies, with the appropriate ammunition. Their lumbering size had slowed their development and adoption. However, thanks to advances in nanocarbons, most frames are constructed extremely lightweight, leaving much more room to install proper armor protection near the hydraulics and engines and larger batteries for power. The feet of mechanoids can be considerably large due to distributing the vehicle's weight onto the ground. Specific variants have large claws or

spikes on the pads and legs to dig into ice and mud. Mechs excel at traversing the landscapes of Avalon, capable of quickly navigating uneven ice shelves, cliffs, and oddly shaped hills and mountains. They are often seen with large railguns attached to the frame, either single or dual. Their role is primarily long-range support and anti-material, which includes bunkers, buildings, armored vehicles, and ships. Mechs also have anti-air and anti-space missiles for defense.

Due to their size, mech combat is expected. Mechs are built with armor that favors the front, side, and bottom. Pilots enter the mech through either the back or front. Front entrances are usually hinged-cocked pits that are recessed into the frontal armor. Rear entrances usually consist of dual hatches. Most mechs run on a crew of 6, consisting of a lead pilot, copilot, weapons, and mechanic directly operating the vehicle, with a navigator and communications operator remotely supporting the vehicle. Mechanics are often needed as mechs are challenging to recover once disabled in the field. Often, hydraulics and electrical issues plague mechs, forcing them to remain in tactical support roles and out of effective frontline use. Some smaller, more combat-ready mechs are fielded in limited use. These are piloted with either remote operators or little crews consisting of 2 Avali. These mechs are used more for shock and overwhelming tactics, like ambushes. These mechs are often fielded with limited ammunition supplies, favoring more armor. After an engagement, they will immediately retreat and resupply.

Mechs are expensive. More advanced, remotely piloted versions often cost more than a medium tank. In addition, they are mechanical nightmares due to their complexity. Despite these drawbacks, they are fielded for tactical support and limited ambushing roles. Their maneuverability in unpredictable environments makes them superior to wheeled and tracked vehicles. Finally, the psychological effect of seeing a large, quickly moving mech is not

understated. Their large size does allow for extremely long-range attacks without direct engagement with the enemy lines. Many enemies will often retreat at the sight of a mech if they even see one.

Air vehicles are extensively used in the Avali force. Combat air vehicles are primarily drones, remotely piloted. They are quick, flying at near hypersonic speeds, thanks partly to not being bound by a living crew. They now carry a host of guided bombs, missiles, and rail cannons to engage in land, sea, and air targets. Combat vehicles can fly low to the ground, avoiding radar detection. They can fly in the stratosphere for long periods, capturing live data in the field and traversing the world on a single charge. Troop transport aircraft tactically insert troops into the frontline, capable of vertical and horizontal lift—Troop aircraft range from smaller, two-pack-sized craft to larger squadron-sized aircraft, able to carry vehicles.

Support aircraft range from small cargo drop airframes to large cargo aircraft requiring dedicated landing zones. Small, agile aircraft are seen in fixed and rotary wing variants. These aircraft will be seen with either an internal or external cargo bay. Internal ones are far more common, as they keep the cargo safe for medium to long distances. External cargo aircraft have the payload attached to containerized bundles, placed in pods outside the airframe. These airdrop vehicles will fly over certain drop zones and eject the cargo to troops. These are only used for frontline cargo insertion and are drones. Medium-sized cargo aircraft are heavily used to transport supplies, vehicles, and troops. Their versatility allows full squadron deployments with appropriate gear, vehicles, and necessary rapid support functions. While not capable of vertical lift, these aircraft can land and take off on short land strips without requiring fully dedicated airfields. Medium aircraft can also carry smaller cargo airframes for repairs or deployment. Large airframes are used for moving large amounts of cargo in a brief timeframe. Usually reserved for

large-scale deployments and natural disaster relief, these aircraft can carry a whole operational station's supply of goods for one month to a location. They can also take mechs, tanks, and other large or heavy vehicles equipped with support equipment with relative ease. The airframes require a dedicated airfield to operate.

Combat and Military support spacecraft are new in the Avali arsenal. Avali operate four styles of military spacecraft: fighter, corvette, destroyer, and cruiser. Fighter spacecraft are small, and fleets of them are stationed in Cruisers. They are also drones, controlled remotely by pilots within their Cruisers. Fighters are usually seen with small rail cannons and hypersonic missiles. They can also enter and exit the atmospheres of planets if necessary. Their role is to engage with hostile entities in space, using their small size and rapid mobility to punch holes into an enemy's defense. Corvettes are four times larger than a fighter and come in drone or directly-piloted versions. Drones are reserved for more combat-oriented roles, whereas piloted arrangements are made for scouting and ambassador affairs. Drones are heavily armored and armed with various missiles, cannons, and point-defense systems. Corvettes have communication jammers, cyberattack software, and Electromagnetic Pulse (EMP) launchers capable of disrupting enemy communications and navigation. Drone corvettes can also enter and leave the atmospheres of planets at incredible speeds. Piloted corvettes often have crew packs ranging from 12-20 personnel. These ships are used for recon, analysis, and contact protocols. These ships are also used for escorting fleets. While capable of combat, they are not as fearsome as their drone brethren, usually carrying a few missiles and rail cannons. They can enter and exit the atmosphere of planets, though much slower due to the crew's presence.

Frigate ships are up to three times bigger than a corvette and house multiple crews for operational work. These ships accommodate

a vast assortment of weapons, equivalent to a drone corvette but 2-fold. In addition to their weapons, frigates house large guided bombs for orbital bombardments of planets, moons, or asteroids. Some are dedicated platforms for certain advanced weapon systems. One such weapon, "GRAZER" is a gamma-ray laser, being an acronym for "Gamma-Ray Amplification by Stimulated Emission of Radiation". They're used thanks to their ability to hit targets before they get a chance to dodge, thanks to its ability to be fired nearly undetected and natural ability to penetrate armor. The weapon is useless in-atmosphere due to the atmosphere itself scattering gamma rays the same way it does every other kind of light. Frigates will also accommodate external charging docks for charging up to 2 corvettes at a time. Destroyers are also battlefield controllers, maintaining star maps, positioning, and points of interest for the fleets.

Cruisers are two times bigger than a destroyer and have nearly identical armaments. The cruiser's size comes from the hangers of fighters housed in their hulls. Additionally, cruisers carry large power plants onboard, capable of charging the fleet when necessary. These ships also house some of the most advanced weapons systems Avali have created. Cruisers are also the operational command centers of each fleet. Each cruiser has every possible necessity needed for a functioning force to survive. They are also responsible for navigation, setting points of interest, and diplomatic decision-making. Higher commands are often seen on cruisers. Finally, cruisers also carry ground troops for rapid deployment. Due to their size, cruisers are extraordinarily expensive, with only a handful fully built and operational.

Seacraft has mostly fallen out of favor in nearly all applications. Dominance in air and space makes sea combat irrelevant for Avali. With that said, the Avali forces do employ airboats for rapid insertions from the sea. These airboats are inflatable and can fit into small or

medium airframes. Some larger airboats can carry a single tactical ground vehicle if necessary. Most are only big enough to hold 1 or 2 packs. These boats are often disposable, left after insertion as packs navigate the battlefield. Other times, boats are used for both infiltration and exfiltration. Airboats have provisions for attaching gauss-style weapons to the haul; however, airboats do not have any notable armor attached to them and can be made inoperational with one well-placed attack.

TACTICS AND DOCTRINE

Avali engage in what humans tend to call unconventional “guerilla” warfare. Avali are incredibly mobile and stealthy during periods of war. Avali forces are rapid and somewhat chaotic in their movements, exploiting weaknesses, and will move behind enemy forces, cutting off supply lines. Static bases are nonexistent, and taking key points to control Avali can be extremely difficult. Additionally, Avali do not care for stationary points. All drones, vehicles, and equipment are fully optimized to move within minutes, engage a target, and reposition elsewhere. Supply drones circle the battlefield, entering and exiting with supplies and gear. Logistics is primarily done by aerial delivery drops, dropping containerized bundles of goods to drones, and supplying troops. On the ground, logistical support is equally as mobile as the engaging troops, often seen with truck-like vehicles and generators.

Avali troop packs are incredibly aggressive with their tactics. Troops are often given goals to achieve in the field, usually through a high command structure. The troops are trained to use all legal means necessary to obtain these goals within a reasonable time. Stealth is heavily used by Avali troops, thanks in part to their hunter upbringings and small size. Sneaking into emplaced camps and disrupting logistical and command support is a common goal and will be done by multiple packs of Avali

troops. Avali utilize paratrooper tactics, with soldiers jumping from aircraft into designated drop zones. Thanks to their wings, parachutes are not necessary when dropping. The creation of decoys and false encampments usually force enemies into ambushes or break away from specific points for exploitation. Direct conflict with frontline soldiers is avoided as much as possible, as Avali are not well-versed in defensive measures. Avali troops often attempt to retreat when put on the defensive, trying to lure enemies into more favorable combat situations.

Avali troops rely heavily on relayed information from their command and intelligence. Real-time data is often transmitted through satellite or radio frequencies, updating augments with navigation and target information. Avali will use data from scouting and combat drones to designate desired targets when attacking. Heavy drones and vehicle crews will then engage the targets from a far distance, thanks to their railgun technology. In some cases, Avali will often attack multiple targets, creating numerous weaknesses and exploits. These exploits are all done while the vehicles and drones are mobile, making retaliation extremely difficult. As communication is done over a closed, peer-to-peer network, troops can closely coordinate their attacks with little delay. Packs are often scattered throughout some regions of operation, waiting for triggers or orders.

Bunkers, buildings, and entrenched areas are not safe from Avali attacks. Avali weaponry and intelligence will knock out fortified positions with ease. Urban warfare can be complicated for Avali, as avoiding confrontation is impossible. Avali troops will heavily use combat drones in these areas to identify targets and possible safe points. Avali troops tend to avoid civilian members as much as possible, relying more on their technology than civilian intelligence. Avali try to take care to prevent accidental civilian casualties, trying to focus more on active combatants. Augment

information allows for easy targeting of civilian and enemy personnel and sometimes prevents weapons from going live.

The core doctrine of Avali is peaceful, despite their large assortment of weapons and aggressive tactics. Avali avoid conflicts as much as possible and exercises more peaceful engagements over aggressive ones. They favor reclusiveness and a low profile to prevent attracting galactic attention. At home, Avali don't find themselves in many conflicts. This lack of conflict is partly due to living in a near post-scarcity society. Minor skirmishes still exist; however, they are localized and often resolved quickly. Avali are not dumb and oblivious and know that some conflict is inevitable. In response to a possible threat, Avali have developed their large armories and trained their troops constantly. Keeping a formidable force at the ready secures peace of mind for the race as they slowly venture out into the galaxy.

MILITARY SERVICE AND STRUCTURE

Military service for Avali is voluntary. Individual Avali or a whole pack can elect to join military service. Avali will be taken into training, where they will develop new military skill sets and tactics. Afterward, job selection is accomplished, and the members will attend a school to learn about their careers. Service commitment is done so through a period of 10 years. If Avali choose to leave the service, they are discharged from the military and undergo a reacclimating period, where they will either return to their former pack or be placed within a new one.

For individuals electing to join the service, a psychiatric evaluation is accomplished for the member and the losing pack. Once deemed fit for duty, the member will be taken from their pack and placed in an initial training period, along with other individuals. This training period mimics early pack imprinting

techniques and builds a new pack unity with separated members. Training lasts two months, enough time to start the initial pack bonds with the trainees. Pack size usually ranges from 4-6, never exceeding 6 members and falling below 3. Packs are taken through a military discipline and tactics training course to learn the basics of military doctrine. This training lasts an additional two months before graduating from a career school. Whole packs that elect to join the service do not undergo the initial 2-month pack bonding training and instead go straight into basic training.

Upon initial military training, Avali packs either be selected or volunteer for jobs. Military jobs are much like those in civilian life but allow the military to function self-sufficiently without the heavy reliance on civilian industries. Packs will accomplish these technical schools within an allotted time frame, which varies depending on the career. Upon completion, packs will be stationed at a designated operation base, where they will perform their job duties alongside military exercises. Packs will often complete their 10-year commitments in the same operational area. Further commitments will allow for opportunities like changing stations and changing careers. If no new obligation is made, the pack is placed in temporary reserve status for another ten years and returned to civilian life.

Specialty careers, like Special Operations units, are given to those Avali packs, which, at a minimum, reenlist for another ten years. These Avali packs undergo physical and additional psychological evaluation before their selection. Special Operations careers experience an intense physical and tactical training school. This career field specializes in infiltrating hardened objectives, retrieving key personnel and information, and sabotaging enemy lines. Another example of a specialty career is expeditionary forces, where packs will undergo specialized space training and learn how to interact with alien races. Expeditionary forces are found on planet colonies and space

stations, providing a rapid defense. Another common career is hatchery guard. Hatchery guards undergo the same training as Special Operations trainees; however, they will also complete a dedicated public relations and hatchery training course. Hatchery guards are assigned to any hatchery and will remain loyal to their career, not participating in deployments. Instead, these guards will participate in rigorous exercises and AR training to maintain their skill sets. Other specialty careers include pack unity instructors, career teachers, and unique advisory roles for the Illuminate.

Avali military structures are standardized regardless of operational branch. At the top of the command structure, Illuminate commanders oversee the entire force, ensuring training, logistics, and missions are properly executed, and needs are properly met. The higher headquarters (HHQ) for operational branches is the next level down. The HHQs include the Ground, Naval, Air, Cyber, and Space forces. Each operational headquarters has two distinct commands: Active duty and Reserve duty. Both commands are headed by career military packs, with more experienced packs overseeing the Active command.

Active commands oversee the operational side of the military. The operational side includes all specialty careers as well. The commands are further divided into Strategic Commands (StratComm) that oversee functional aspects of HHQs. StratComms are divided into Operations (SC1), Intelligence (SC2), Communications (SC3), Logistics (SC4), Medical (SC5), Training and Exercises (SC6), Maintenance (SC7), Engineering (SC8), and Administration (SC9). A career functional expert pack leads each StratComm, often rotating out command packs every three years. These leaders will make strategic commands within their assigned function and will ensure basic HHQ operations and goals are met accordingly. Each StratComm controls a functional strategic office at each duty station.

From StratComms, Wings are the next level of military command. Wings are often in charge of operational areas and are made to be more field-level in decision-making. Each wing is divided into nine divisions (DVN) under the functional StratComm, supporting each operational function. Lead packs under the command of a wing pack leader head each division. Divisions are often clustered into Squadrons (SQ) based on their functional impact. SQs include Operational SQ, which comprises Operations, Intelligence, and Communications; Logistical SQ, which includes Logistics, Maintenance, and Engineering; Medical SQ; and Administration SQ, which provides Training and Exercises, and Administration. SQs are further broken down into tactical-level flights (FLT), where the execution of orders and goals are accomplished.

A Flight Pack commander oversees clusters (CLT) and packs (PK) within each FLT. Multiple FLTs can exist within a squadron, all able to accomplish the same operational goal. Clusters are numerous packs assigned to the same function. Clusters are commonly seen in maintenance, operations, and logistics careers. Larger functional areas can often see many large FLTs of troops, whereas small, more tactical locations might have very few. Packs are broken down into a firm hierarchy of 1 pack leader, 1 assistant leader, and 2-4 troops.

When addressing members within the military, Avali will begin with rank first, then name. Leaders will be higher in rank. Rank is often rewarded to dedicated workers who show excellent leadership and communication skills. As ranks are given to individual Avali, the collective pack will rise in rank. Packs will take on more leadership, strategy, and tactical roles as they progress through the ranking system. Ranks are separated into three categories, General enlisted, Warrant Officers, and Career Officers. Ranks are further broken down into three sections, with three grades. Packs have five ranks regardless of category.

The Enlisted force serves as the direct line of mission accomplishment and is for completing tactical-level goals and objectives. The enlisted corps comprises of newly enlisted personnel, with only 10% of the corps being Avali, who have reenlisted at least once. For Enlisted ranks, they go as the following, from lowest to highest: Basic Level, which includes Recruit, Troop, Specialist; Tactical level, which includes Corporal, Pack Sergeant, and Flight Sergeant; and Field level, which includes Lead Flight Sergeant, Master Sergeant, and Cluster Sergeant.

Warrant officers are given to those Avali packs that have reenlisted at least once. Warrant officers are career field experts who create tactical goals for the enlisted force and oversee field operations. Additionally, Warrant officers are often put in direct leadership and mentorship roles, having opportunities such as instructors and embassy roles. Their ranks are broken down as follows: Field Warrant Officers, which includes Career Field (such as infantry or vehicle maintainer) Warrant 1-3 (CW1-3), Career Field Squadron Warrant Officer 1-3 (SW1-3), and Strategic Warrant Officer 1-3 (WO1-3).

Career Officers are Avali packs that have dedicated multiple enlistments to the military, usually more than 40 years. Officers lead strategically, overseeing clusters and squadrons of Avali. They will ensure all necessary sustainment and operations remain fulfilled, in addition to providing mission accomplishment in the field. Officers also take charge in case of communications failure, ensuring a stable command structure is maintained and missions are accomplished as necessary. This degree of autonomy allows Avali forces to operate without direct contact with HHQs and StratComms. Unlike human officers, any Avali pack can be pilots. Their rank structure is as follows: Tactical Officers, which are Fletch, Lieutenant Pack, Captain Pack; Field Officers, which are Feather Pack, Major Pack, and Colonel Pack; and Strategic Officers, which

includes Marshall Commanders, General Commanders or Admirals for Naval and Space, and Generals of Armed Forces or Fleet Admirals.

Pack ranks are based on the overall ranking of the pack. Three or more members in a pack will have an equal or higher rank needed to elevate the pack to the next rank. Each rank category has five pack levels, all with the same name. Pack levels are indicated with either a specialty symbol on their career insignia for Enlisted and Warrant Officers or a marking on their rank for Officers. The levels are: Basic Troops (BT), ranks 1-3, Pack First Class (PFC), ranks 3-4, for tactical levels; Specialist Pack (SP), ranks 4-5; and Career Technical Pack (TP), ranks 5-7, for field levels; and Command Pack, ranks 7-9, for strategic levels. When whole packs are addressed, they are called by their pack rank level, followed by the pack leader's name. Once a pack has achieved its rank, it can only lose it by disciplinary action or disbandment due to falling below the minimum number of members, which is 3.

Ranks are worn on both the helmet and chest pieces of Avali forces. Career field badges are worn on the right side of the chest piece. Specific careers have unique cloaks or sashes worn with their uniforms, which will have their squadron or career badge embroidered on the clothing piece. Pack ranks are placed above the career badge, having distinct appearances for each level. For officer packs, their pack rank is integrated with their rank piece, with some elements of their armor having sleeve or helmet markings. Avali troops will only wear the rank of their respective category. Wearing multiple ranks is not permitted.



Figure 8 - Pack and individual rank structures

SPACE EXPLORATION

Space is the next great frontier for Avali explorers and resource collection. Avalon has been exploited heavily for all its habitable space and resources to maintain its high standard of living. This resource exhaustion has forced Avali to expand its population outwards. The Illuminate faction has aggressively undertaken expansion out into space. Their interaction with the galactic community has been peaceful and reclusive, with very few Avali seen outside their home Uresk Star system. The ones that are found are usually ambassadors, explorers, or scientists.

Avali utilize a combination of sub-light and warp-style drives to navigate the cosmos. Their star system has become heavily developed, with space stations, communication arrays, elevators, mines, and habitats scattered throughout the system. Spaceships can constantly be seen moving, delivering cargo and passengers to different areas of the system. The Illuminate controls the vast majority of the system, with a handful of Independent stations and mines operating within the controlled areas. Venturing beyond the Uresk home system, Illuminate and Independent factions laid claim to nearby star systems. While not as developed, these systems are centers for large mining operations and scientific experimentation.

COLONIES AND HABITATS

Exploration into space is costly and often requires Avali to remain in the cosmic frontier for long periods. To accommodate these needs, Avali have developed multiple styles of housing structures to sustain them. These styles fall into two categories, world colonies and space habitats. Each housing structure has its benefits and drawbacks, with

space habitats making up a good portion of the constructs. Within the Uresk star system, habitats are found around Skomar, Yellow Eyes, Avalon, Elysium, and Midnight Star. Outside the Uresk star system, only a handful of space habitats and colonies exist. Most of these structures are located near or on a system's second or third planet. The habitats and colonies found here are mostly mining and raw material processing facilities, with a select few for scientific and academic advancement. Most Avali spend their time on spaceships, orbiting the planet. Avali often rotate between Uresk and their working star system, allowing them to return to Avalon for rest and recovery.

Establishing bases and colonies on planets and moons is a costly task. Avali developed a colony module construction system to minimize the cost of construction. The system uses small deployable pods and large container-based buildings connected through pressurized and climate-controlled tubes. Ships will deliver these containers and pods to their destination, then a crew of Avali will connect the buildings. Pods contain compressed air, temperature control units, energy, storage, sanitation, and hydration packs to sustain the facilities. The primary containers include nearly everything to get started on an alien world, from food to computer systems. Containers can be fitted with multiple pods, allowing for customization of the containers to fit desired needs. Some containers can be combined, creating large work centers, common areas, or storage units.

As time progresses, ships deliver more containers and equipment, quickly establishing a foothold in the world. The module system is designed to be picked up by vehicles when the colony needs to move to another location. Air and space transport is significantly faster than ground transport; however, the container system cannot operate during this time. For

ground-based vehicles, containers and pods can continue operation during transport. When a colony becomes large enough, specialized tents and building structures, like the ones found on Avalon, will be seen more often. A notable difference between Avalon and off-world colonies is the verticality of buildings. In some instances, off-world buildings will often be shorter due to higher gravity restraints, as Avali cannot fly to higher locations. Instead, colonies will usually be sprawled out. While colonies are expensive to create and maintain, they have the benefit of preventing space sickness, mental degradation, and intense body training from retaining the bodies of Avali. Colonies are often created in the ideal ranges possible on foreign planets to reduce the demand for climate systems. Colonies are much more forgiving on what specialties are permitted worldwide, as space is not a major limiting factor.

Habitats are large space stations often positioned within the orbits of planetary moon paths. These immense structures are built to house Avali for many years while they work on neighboring planets and moons. Habitats are built around large power plants, such as nuclear reactors, and are identifiable by their circular disk design, which rotates around the central core. Communication antennas and operational decks can protrude from the top or bottom of these habitats. In conjunction with the habitat's rotation, Avali wear charged exo-suits that keep them bound to a surface of the station, simulating a weak form of gravity. Avali in habitats undergo pressurized training each day within dedicated workout chambers. This process prevents the loss of muscle and bone structure while living in the habitat.

Habitats are expensive to maintain, requiring constant supplies of air, food, hydration, and other means to sustain life in space. They are also limited in their space and adaptability, only permitting specific fields and

the number of Avali to live within them. The mining and research operations near the planets and moons recuperate costs and limitations. Habitats also benefit from maintaining an optimal climate range for their inhabitants. Commonly, Avali who live in habitats work as drone operators. Mining stations are connected to habitats, usually through a space elevator, and harvest new materials for processing. Multiple science fields also operate on space habitats, testing new theories and space experiments. In addition, new engineering prototypes are tested on nearby worlds, moons, or in space. Habitats rely on smaller space stations to retrieve and send cargo and passengers, as they do not have dedicated shipyards or docks.

Avali are capable of living within alien colonies without issues. Their relatively docile nature allows them to integrate well with other species. Avali prefer to live in colonies established in colder climates or have access to tunable climate control systems to fit their needs. Despite this, Avali are rarely seen as a permanent party in any foreign colony. Generally, Avali are traveling through foreign colonies for supplies, and are only seen within these brief moments. Many drawbacks exist that make coexisting undesirable for them. Access to Nexus networks is nonexistent, as alien territories would need to work with the Illuminate to establish some form of communication array or remote network. Diet and hydration needs are also significant drawbacks, as ammonia and carnivorous diets are hard to find on alien colonies. Alien races tend to be more stagnant than Avali, in addition to being more individualistic.

TECHNOLOGY

Avali started the space age by developing rocket-boosted aircraft that could pierce the stratosphere. Rockets would later

develop into dedicated spacecraft launched from the peaks of mountains on elevated platforms. This method allowed the rockets to launch above the dense lower atmosphere of Avalon, decreasing air resistance. Avali continue to use platforms like these at many Avalon spaceports and can often be seen towering among the buildings of many cities.

Spaceports are the central hubs for sending Avali and cargo out of Avalon. Some of these ports will utilize space elevators to send cargo rapidly to space stations. These elevators use thick nanocarbon-wrapped copper cables with magnetic drives to send platforms to and from space. The space stations use electrostatic drives to maintain an orbit and mitigate as much stress as possible on the cables, which is caused by weather, gravity, and general wear. Seven lines are used in conjunction, allowing for easier replacement of the cables, which is frequent. Cargo shipments are the primary use of these elevators, with some limited passenger uses. Cargo will be sorted and sent out on space frigates to their ultimate destination.

Space construction is done modularly. Every space station has been designed to be manufactured in space facilities, then shipped and assembled at their requested destination. For large sections, dedicated towing frigates will send all necessary components, materials, and tools, along with the large section, to the destination. Assembly is done rapidly, as all materials are delivered on the spot, and most

units are already completed. Spaceship construction is done similarly. Ships are built on modular frames that easily attach or remove specific components. Some modules are produced en masse and shipped to shipyards via a space elevator. Others are made in space due to their size. The minimum frame size built within zero-gravity facilities is cargo frigates. Avali use extensive manufacturing facilities to construct small spacecraft. These spacecraft, particularly fighters, drones, smaller passenger buses, and corvettes, can fly out of planet and moon atmospheres. These manufacturing facilities are located either underneath or next to elevated spaceport platforms. This optimization allows for rapid deployment of the spacecraft once construction is complete.

Figure 2 - Cooling fin retracted (top) and deployed (bottom)

Ship armor is thick and designed to withstand small particles floating in the star system. Larger ships utilize magnetic repulsion shielding to deflect certain particles and some radiation from the stars. Due to the energy needed to run such a device, they are limited to large ships with multicore nuclear reactors. When dissipating heat, radiators externally funnel the heat into the vacuum of space, keeping only a specific temperature within the spacecraft for crew

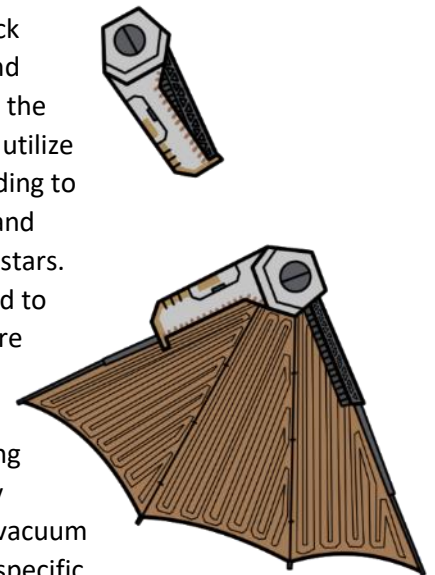

comfort. These radiators can be identified visually by winglets or fin-looking sails attached to the ship's exterior. Some smaller spacecraft have heat radiators protected with a movable panel activated when a particular temperature is met. Avali

Figure 1 - Examples of some Avali ship hull designs. Some smaller ships and drones are highly specialized, still fitting within the ship's modular construction system

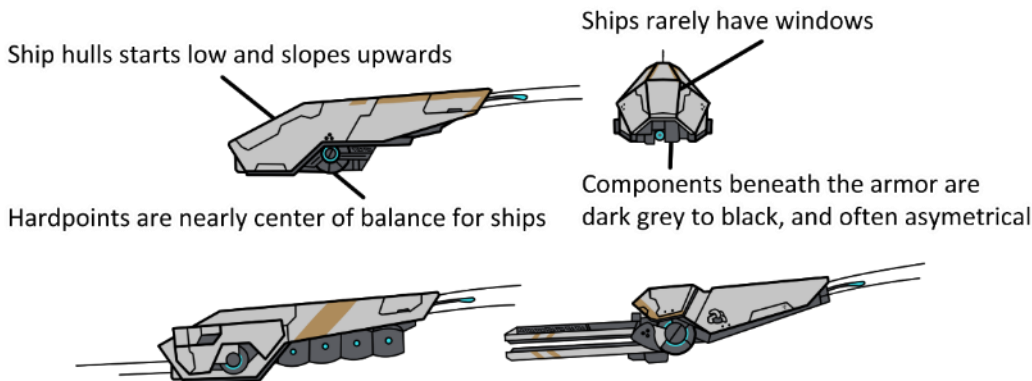

ships are distinguishable by their flat and wide design structures. Ships utilize multiple horizontal levels to accommodate crew and cargo requirements, with only larger ships expanding upwards.

Photovoltaic panels, also known as solar panels to humans, started their development and adoption during the space era. While not viable on Avalon, these energy panels would find a home on nearly every space station and craft employed by Avali. The panels often charge batteries, providing auxiliary power to satellites and work drones. The panels are often manipulated, so they always face the Uresk or other starlight sources. Panels are usually constructed in space rather than on Avalon to decrease transportation time and cost.

Sub-light drives are the most popular form of ship propulsion the Avali currently use. Magneto-plasma-dynamic (MPD) and magnetic-field oscillating amplified (MOA) thrusters are the two standard main drives used by Avali fleets. For more precise movements, Hall-effect style and electrostatic thrusters are used. The main drives are large and powerful, capable of propelling spacecraft between 1750-5000 kilometers a second (km/s). These drives often

run off fission reactors coupled to solid-state batteries. Solar panels are used outside of the

spacecraft to harness additional energy. The current speed of sub-light drives is adequate to travel within star systems, while warp drives are designed for specialized ships.

Warp drives are used to travel between star systems. These drives create a negative mass effect between two points within space, creating a fold and decreasing the distance

between those points. Subsequently, a tear known as a wormhole is made between these points, large enough to send a sizable fleet of ships, usually 20-30 ships at a time. This exploit has allowed Avali fleets to rapidly traverse the nearby star systems without spending years at light speed to reach them. Due to the immense power requirement of these drives, the drives are only limited to designed ships, known as Warp Ferries. Ferries are large and expensive ships with a heavy focus on energy production and storage. This focus allows the vessel to create enough energy to cause a warp and transport ships. These ships target the central star of a system, using them as a form of mass anchor point, and are seen orbiting around stars to create warps for ships. Ferries must travel with whichever fleet to each system. Only one ferry can travel simultaneously to a targeted star system to avoid collision between fleets. For optimizing transport, ferries will wait until a certain number of ships are ready to jump into a wormhole, a minimum of 10 ships. Multiple ferries can be orbiting a star, controlling traffic flow. After a ferry has finished a jump, it will be unable to jump again for 25-35 days. The ship replenishes its energy storage during this time. Onboard reactors are scrambled and reset back to idle due to the large discharge of energy and preventing meltdowns. The ship will immediately begin recharging its batteries from the nearby star using photovoltaic panels.

Warp ferries are also central communication and traffic control hubs for outside systems. Their large energy banks allow for communications throughout the star system when communication satellites have yet to be fully established. The amplified communication networks can reach outside one star system, with notable latency. Traffic control maintains some order for ships traveling within and between systems. Traffic control allows for scheduling warp jumps with the most optimal

Figure 3 - Examples of sublight drives with the common (top) and combat (bottom) styles

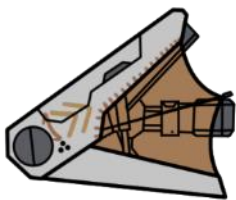
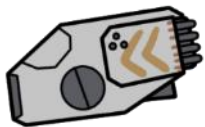

number of ships at a time. Furthermore, ferries will have small maintenance hubs on board, allowing repairs to be made to the vessel before jumps.

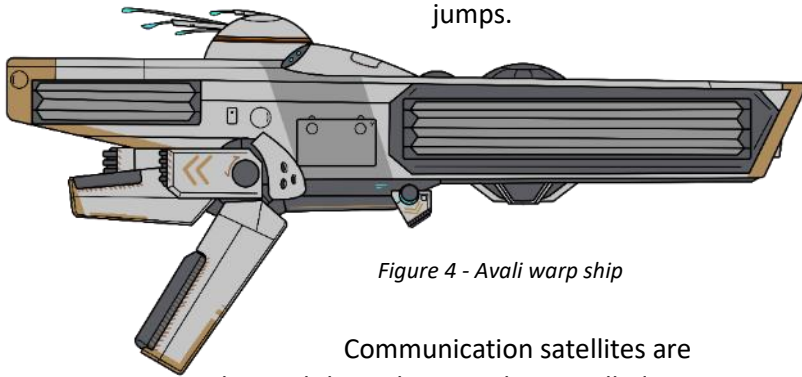

Figure 4 - Avali warp ship

Communication satellites are located throughout Avali-controlled star systems. These satellites are usually locked to an orbit of a planet or moon and allow for a constant flow of communications between ships, stations, and other planets. A neighboring space station or space habitat maintains these satellites. Avali ships will often have an extensive communication array located towards the front of their vessels and is used for transmitting data between neighboring stations, crafts, and satellites. Satellites are often powered by photovoltaic panels, with only certain ones dedicated to communicating across multiple star systems having larger power plants attached. These larger communication satellites are often found near the center of star systems, usually conjoined or maintained by a dedicated space station.

Space stations are found on nearly every planet in the Uresk system and scattered across other star systems as needed. Stations are simple in design and somewhat mimic their larger habitat counterparts. The central core is a power plant with larger modules attached for specialized needs. Modules can range from large communication servers to docking hubs for ships. Stations are often used as transient points, a hub to deliver cargo and passengers, for use in mining fields, research stations, and transferring passengers to habitats. Stations range from small cargo hold areas to large

shipyards with elevators. Stations will often have operational and maintenance platforms for working on satellites and ships.

Avali harvest and grow their needs on stations and ships for sustainment in space. Certain mining stations or platforms often gather oxygen and other solidified gasses from space to replenish ship, station, and habitat supplies. Some gasses are captured on Avalon to maintain a specific micro-organism count and air mixtures. The advent of vat meats has allowed certain ships and habitat sectors to become dedicated food processing centers. Food items are grown in vats, then processed and delivered elsewhere in the star systems. Larger ships, such as military cruisers, large frigates, and warp ferries, have small food-growing vats to help sustain the crews of these ships. Purified water and ammonia sustainment is done through chemical reaction plants found on all stations and habitats. These plants take hydrogen, oxygen, and nitrogen gasses and form the desired chemical for hydration. Ships have large storage tanks of ammonia and water, usually refilled during docking.

Avali have developed a specialized augment known as the Environmental Protection Augment, or "EPA," for operations on planets or moons. The EPA is not just a single augment but a series of augments done to an Avali that, while not perfect, provides specialized pressure, temperature, and structural adaptations for the environment. Avali still wear protective suits and armor to protect from harsh and alien environments. Respirators are also used heavily due to toxic air or simply too hot to breathe. The EPA allows for a lot more flexibility in such conditions. The combination enables Avali to operate in environmental conditions like Earth's, though at a limited capacity.

Civilian mechanoids are commonly seen in space and alien world environments.

Compared to their military counterparts, civilian mechs are lightly armored, if at all. Mechs are used primarily to mine raw materials from designated sources and short transport of supply containers. Mechs are often focusing more on life sustainment and tool operations. Mechs are usually lightweight, with small batteries to last a single day before a recharge. Mechs are modular and, although they may lack power and armor, can accept a multitude of specialized modules to change the characteristics and performance of the vehicle.

FLEETS

The Avali Illuminate has three distinct fleets, each of which has a dedicated field in which they operate. These fleets are the Avali Expeditionary Fleet (AEF), Avali Defense Force (ADF), and Avali Commerce and Logistics Fleet (ACLF). Each fleet is specialized in its respective fields. All fleets are based on the spaceship singular chassis system and have special modules manufactured for completing their jobs and missions.

AEF is responsible for exploration and scientific discovery. AEF falls under the control of the Illuminate's Avali Adventure Corps (AAC), charged with accomplishing their specific mission. Ships are easily recognizable from their

sleek and stealthy designs, made for entering and leaving star systems without causing disruptions or drawing attention to themselves. Their vessels often have labs, advanced computers, and large data storage modules. Additionally, AEF fleets usually deploy the most advanced warp or sub-light drives for testing and navigating remote systems. AEF ships also carry an ambassador pack for interacting with other galactic races if the need arises. Adventure fleets do not interact with alien races; instead, they focus on discovering and researching scientific anomalies. Of the three fleets, the AEF is the smallest.

AEF employs three styles of ships. The smallest is based on the corvette frame and are exploration drones. These drones investigate scientific anomalies and interest points without disturbing the nearby areas or alien stations. These science corvettes lack weaponry and employ a series of measuring and observation tools. Most of the energy is dedicated to stealth. Next in size is the science frigate. These ships are medium-sized compared to others in the fleets and hold research, academic, and ambassador crews. These ships have large data centers for processing research, calculations, and maintaining a remote Nexus server. These frigates are also outfitted with larger life support systems, able to sustain Avali crews for

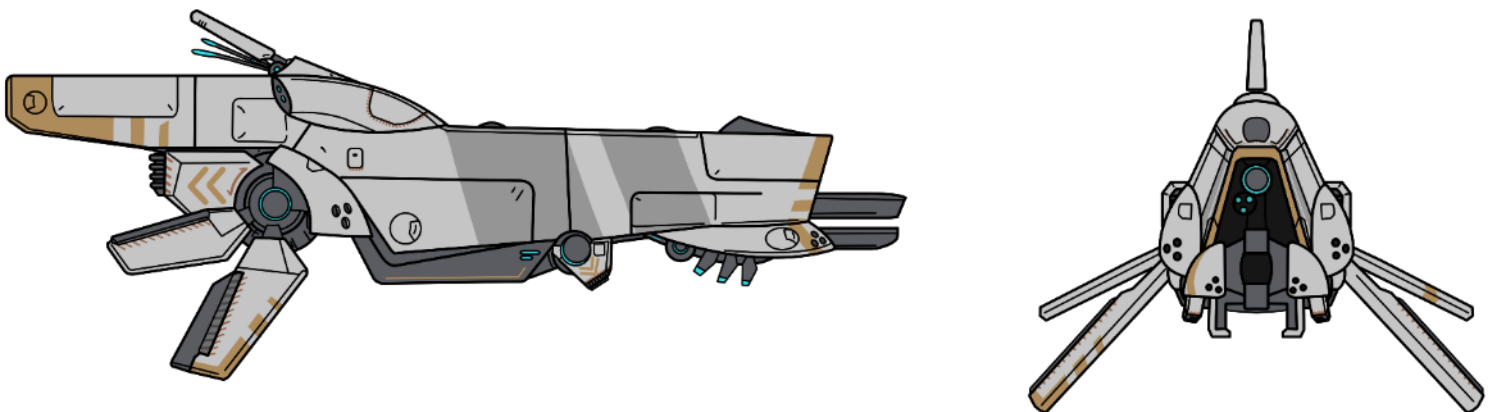

Figure 5 - Avali Frigate outfitted with "GRAZER" armaments.

extended periods without the need to dock at a nearby station. Finally, there are the larger prototype science ships. These ships are built from the destroyer frame, with the provisions of weaponry removed. These prototype ships are fully serviceable; however, they often employ novel technologies, such as experimental warp drives, sub-light drives, measuring tools, stealth technologies, and ship modules. For passive stealth, these ships are distinguishable by their long, sleek designs, often coated with a darker color than regular science ships. Additionally, external windows are nearly nonexistent, further adding to their unique appearance.

ADF fleets focus on the defense and protection of Avalon and Avali-controlled systems. This fleet falls under the command of the Illuminate's Space Defense HHQ. ADF ships range from small, agile fighter spacecraft to large cruiser ships with hangers, large weapon systems, and attacking forces. ADF Ships also have the thickest hulls available per class and employ some magnetic field shielding for their larger ships. ADF fleets are often seen patrolling the star systems, practicing drills and exercises to maintain combat effectiveness. They are also responsible for a form of customs, where inspection of cargo and passenger ships is undertaken to ensure security. The ADF maintains a small fleet of warp ferries for jumping between star systems. Due to their tactical significance during wartime, the ADF becomes responsible for maintaining all warp ferries. For more in-depth information on the ADF's weapon systems and diplomacy, reference the [Military](#) section of this chapter.

The ACLF is the largest fleet employed by the Illuminate. They manufacture and deploy cargo and passenger ships, along with mining stations, communication satellites, spaceports, and

space elevators. To maintain a large fleet, multiple Illuminate and Independent controlled agencies are grouped into one command, each specializing in certain aspects of the fleet. Ships are constructed with the primary goal of transporting the most considerable amount of goods and passengers as safely as possible. ACLF also ensures space commerce and data records are synchronized with the Nexus and Oracle systems. The fleet uses warp drives the most compared to the other fleets. Due to this, the ACLF is charged with maintaining warp ferries during peacetime operations. During wartime operations, the ACLF cargo and passenger fleets fall under the ADF HHQ's Stratcomm 4 for maintaining logistical lanes for the military.

ACLF fleets consist mainly of freighters and passenger spacecraft. Freighter frames range in five sizes, from small, near corvette sized to massive cruiser-sized cargo carriers. Passenger space frames come in three sizes, from buses to medium-sized passenger space ferries. For frigates, the smallest freighter, known as a "Catalina (Caklerah)," is slightly smaller than a regular corvette. These ships have one cargo hold, with provisions to carry pods on the outside of the spacecraft. These small cargo carriers can quickly enter and exit atmospheres and have vertical takeoff and landing capabilities, removing the need for a

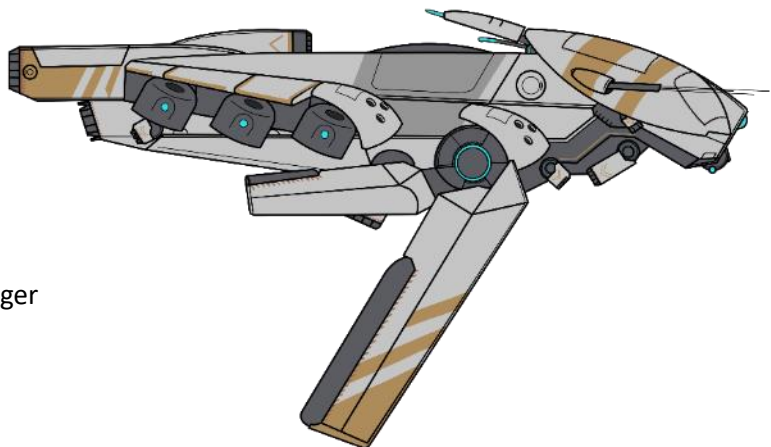

Figure 6 - Catalina ship

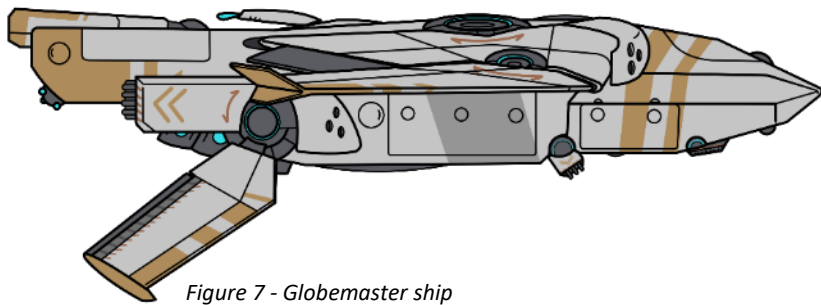

Figure 7 - Globemaster ship

dedicated landing strip. Next in size for freighter is known as the "Globemaster (AwakomrR~)" class. These ships have two large cargo holds with provisions for external pod attachment. The Globemaster can also enter and exit atmospheres but requires a small landing strip to land safely. These freighter also can travel at low altitudes and low speeds. They also have the capability to drop cargo loads from the bays and launch pods from the craft's exterior.

The medium-sized freighter is known as the "Freighter." These spacecraft are more extensive than their Globemaster counterparts and nearly four times the size. The freighter has six total cargo holds, capable of carrying multiple vehicles and cargo. The spacecraft can only enter the upper levels of world atmospheres, if at all. These ships are built in space, at space stations. They are also loaded at these stations using space elevators and have

external docking provisions for transferring goods to another spacecraft. Next in line is a bulk carrier-style ship known as the "Rhyes" class. These ships are long, with 12 cargo holds and provisions to mount containers on top of the vessel. Rhyes class ships are most seen traveling between planets and space stations, carrying large cargo to sustain the space fleets. Finally, the super freighter class is known as the "Galaxy (U'srrik)" class. These large freighters are slightly smaller than a cruiser but much broader. They have a total of 24 cargo bays, along with provisions to attach containers to the ship's exterior. These frigates often travel between star systems, delivering many goods to controlled territories.

For Passenger spacecraft, the smallest ship is known as the "Bus" class. These small ships can carry up to 100-120 Avali and, much like the Catalina class, can take off and land vertically without needing a landing strip. These ships transport Avali passengers rapidly into space, docking at space stations or habitats. The next size ship was built from the Frigate class of ships and could comfortably carry 520-580 Avali passengers. These ships transport passengers between worlds, stations, and other destinations. They are also faster than the standard freighter due to their lighter weight and better-optimized design.

Finally, there is the largest ship known as the "Starliner." These ships are built off the destroyer class of ships but are constructed entirely with passenger comfort in mind. They can carry 900-1000

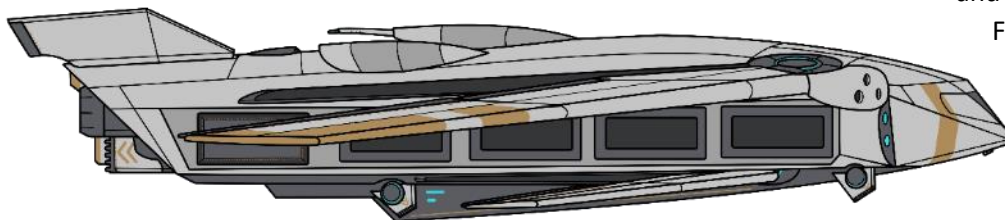
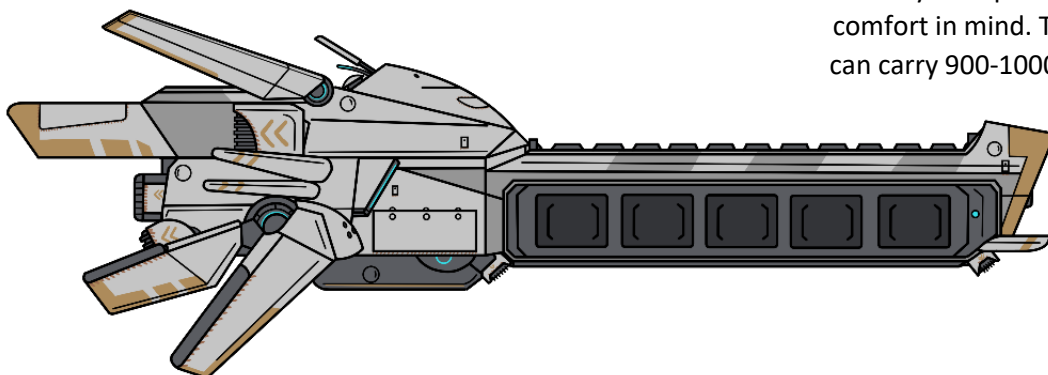

Figure 8 - Freighter (top) and Rhyes (bottom) ships



passengers at once and are often seen traveling between the star system, hence the name. Each of these ships has small provisions for cargo, mainly for carrying small amounts of supplies and passenger goods to their destination.

DIPLOMACY

Avali are peaceful and reserved while wielding a significant force in case of aggression. The Illuminate holds technology and information secretly to the outside community. Some diplomatic cooperation can be seen with ambassadors and limited trade negotiations. Avali prefer to be left alone, only viewing the galaxy as a new frontier to explore. The race has no desire for conquest. They also realize that the circumstances of their existence are extraordinarily improbable, and finding suitable habits outside Avalon would be exceedingly tricky compared to most other galactic races.

Avali limit their interactions to only particular races. Avali are much more cordial with races that favor unity over individualism. Additionally, races seen as more peaceful in their interactions are also preferred. Friendly interactions can include trade relations, information sharing, and resource sharing. Races that rely on a singular ruler, or utilize their aggression as a form of power, are often dismissed or completely ignored. Furthermore, races that hold specific belief systems, such as religion, subjugation of others, and enslavement, are also avoided.

Illuminate Ambassadors are often the only interaction most galactic races get whenever dealing with Avali. Ambassador packs are found either through interacting with the AAC fleets or through designated embassies established by the galactic community. Ambassadors are used for negotiations, trade, and navigation permissions. In return, Ambassadors communicate interests, relations, and appropriate responses to the Galactic

community. Ambassador packs consist of 5 or 6 members, all equally capable as the other, in addition to an Expeditionary guard unit pack, usually composed of 4-6 members. The galactic community receives upwards of 12 Avali members to represent them on the galactic stage, per the embassy. These members rotate out every three years for rehabilitation and recovery.

Avali galactic representation chambers usually house certain unique items that cater to the Avali race. Items include tent fabrics, Nexus access, food, hydration, and proper cooling for traveling and stationed Avali. Chambers are designated safe, neutral zones within Galactic embassies. These areas often accommodate travelers, which is not usually seen in other alien sections. Chambers are found on either large space stations or a designated neutral planet. These chambers are used to communicate with the Avali race diplomatically. Avali will conduct a sizable portion of their duties within their designated area, only leaving when needed or requested. When Avali Ambassadors leave their designated chambers, they are accompanied by a set of Expeditionary guards to protect them. Expeditionary guards are also seen around these sections, deterring possible threats.

Explorer packs are also seen outside the Uresk home system, though they are much rarer. These packs usually travel within dedicated science ships equipped with the most advanced drives and life support equipment. Explorer packs include various science and engineering fields for researching and developing technologies and galactic information gathering. Traveling outside of the Uresk system is still dangerous. If a failure occurs within the ship, engineers and mechanics will have to repair the ship on the spot or risk being stranded for unknown periods for rescue. Explorer packs will sign an

agreement with the Illuminate, stating that their exploration could result in being left and possibly death due to resource exhaustion. Explorers and scientists will record their findings on chiplets for transfer upon return to Uresk. Communication with the Nexus and Oracle systems can be slow, if available at all. These packs will often have remote variations of these systems for centralized computing and data storage onboard the ship.



Figure 10 - Avali-Illuminate space propaganda poster

CHAPTER SUMMARY

The struggle of developing into an advanced society was immense, as Avali struggled to create a solid foundation to grow beyond their hunter-gatherer phase. The constant shifting of the world and stable food supplies plagued many early civilizations. Over time, Avali will persevere, leading to the rise of the most predominant government faction, the Illuminate. While not all Avali fall under the guise of the Illuminate, with Independent and Rogue tribes and colonies still scattered across Avalon, the Illuminate's reach and influence has forever changed history for the alien race.

Avali have a dense, pack-based culture. Their idea of collective betterment of the pack is one that most struggle to wrap their head around. Avali do not prioritize the individual self over the pack, though individualism is expressed in more artistic and hobbyist ways. Avali are incredibly artistic, something they love to cherish and show to everyone willing to observe. With the further development of an advanced society, towards more of a post-scarcity one, the emphasis on individual artworks and musical pieces has only grown more in popularity.

Avali do not form couple-style relationships together like humans. Instead, they are often mating together, usually with other socializing packs. Furthermore, Avali lay their eggs in communal hatcheries. The community raises Avali kits, frequently rotating through packs to learn new skill sets, with having a lead mentor or teacher though most of their adolescent life. Once Avali reach adulthood, they will be assigned to a workforce, either voluntarily or forced.

The Avali language is complex. The language focuses on many little cues and sound bits to be appropriately enunciated to convey the proper word or sentence. Emotions play a

prominent role in the writing of the language as well, as the written language was developed with the idea of being played by sound, then read with eyes. Humans could not speak Avalian Core properly, as certain sounds rely on certain parts of the Avali anatomy to be present. Likewise, Avali would also struggle to speak nearly all human-based languages, lacking certain features.

The technological development of Avali was slow in the beginning, barely making it past the hunter-gatherer phase and into stationary societies. Instead, Avali chose to capitalize on the mobile hunter-gatherer roots, developing more mobile societies and the necessary tools and technologies to make their mobility easier. While slower than the development of human technology, the result has given Avali the unique benefit of being extremely mobile and lightweight in their possessions and technology, with only certain cities becoming their stationary development centers of the world. The technological leap from the Industrial to Space age was rapid once cities became more viable with ore processing. To this day, Avali are still seen in tents and tribes, hunting across Avalon with impressive technology.

As with their technology, their military doctrine and tactics are mobility focused. Avali are rapid in their attacks, focusing on a mixture of exploits and long-range attacks to create chaos amongst the enemy. Avali are aggressive in their tactics, with the necessary logistic support to back them. While their tactics are fierce, quick, and mobile, Avali tend to be more peaceful towards others, including themselves.

The final frontier for Avali awaits. The Space age has taken a firm grip on the race as they progress outward from their star system. Their technological progress is something to be in awe of and held quite secretly by the Illuminate government. As Avali progress outward into the galaxy, their interactions with

other alien races become inevitable. Avali avoid interactions with other alien races, opting to be peaceful and reclusive. Their goals are more for technological progress and sustainment of their current home world standard of living rather than conquest.

In the final chapter, we will dive into the development of a personal Avali character. Additionally, the chapter will review how to incorporate Avali into universes and key characteristics when playing games with Avali characters. The chapter will also cover some of the established universes where Avali can be found. Finally, there will be a reference guide for all the materials used to develop and execute this lore guide.

[תמונת איור המפרט את המוצר]

AVALI AND YOU

CHAPTER 3



AVALI AND YOU

Avali are an open species. The species is capable of being morphed into nearly any medium. The material outlined in this guide allows creators to create expansions or extra material further, even integrated into other fictional universes. While written along the same vein as RyuujinZERO's original concepts, strict adherence to this guide or Ryuujin's source materials is unnecessary. Some basic rules must be abided by to ensure that Avali are still recognizable outside their base lore. This chapter will expand upon assistance in creating an Avali character and implementing the race into other universes.

CREATING A PERSONAL AVALI

Many reasons exist for an Avali character, and all of them are valid thanks to the species' openness. The creation of a personal Avali character capitalizes on individual creativity and expression. Avali characters are often small representations of their creators, a form of anonymous expression done over the internet. Some Avali characters were created based on a universe and implemented that character into it. This form of self-insertion allows fans of a universe to become more invested in the lore and story. Other Avali exist because of their innate cuteness and are more of a simple digital shell that people use to interact with others.

Avali characters, regardless of the universe they are put in, all share standard features inherent to the species' existence. Nearly all features are purely physical but are mandatory. All Avali must be a digitigrade, bipedal creature. Their heads possess four ears and two large eyes. Tails and wings are also required and can be either augmented or natural. Avali do not have noses or nostrils on

their snouts' fronts. They only have two fingers and one thumb on each hand and three toes on their feet. Claws are common but not mandatory, along with the scutes and pads on the hands and feet. Dewclaws are extremely common but also not necessary. Their wings are feathered from the body's base to the tip of the hand. While feathers are mandatory, they can be removable augments. A short but still noticeable snout is also mandatory.

Other traits are not mandatory and are often supplemented with alternate variants. Specific characteristics like size, colors, and weight are all completely customizable and do not conform to a standardized set of rules. Avali characters can range widely in size, with some as small as 1 millimeter and others towering over three or more meters. Avali are seen more as omnivores rather than obligate carnivores. Avali teeth favor raptor-like or shark-like styles instead of solid plates. Head and eye shape can also vary but often fall within the established guidelines. Many Avali characters are seen with more forward-facing eyes and snouts that are either slightly larger or shorter than the standard. Complete removal of the snout, or large protruding noses, like canines, is incorrect. While not typical, the composition of Avali can vary between certain characters, some abandoning the natural chemical makeup for more Earth-like compositions.

Avali can have any application of any color and pattern to their feathers. Feather patternings and colors do not have a mandatory set of rules. Eyes also fall under this category and are often seen on characters with distinct pupils and corneas instead of the dark purplish-grey or black natural colors. Augments, mostly cybernetic limb replacements, are also seen. Head crests can also be stylized in any way, most preferring to stay with a more natural feather look. Some Avali elect to have a pseudo-nose design added to their character. Most

Avali colors and patterns are based on the original "Starbound" mod. Naming schemes and languages used by Avali characters do not adhere to any standard. An Avali can be named anything and be fluent in any language. Most characters use the Avali scratch font for creating Avali-based gear and language, as the scripture is close to the core Avali language. Many internet Avali characters can interpret English, written, spoken, or fluent.

Templates and artists exist that can capture the desired Avali character on a reference sheet. In addition, free digital avatars can capture the design in a 3D space. The existence of these mediums allows for your character to come to life. When creating a character within an established universe, include some samples or the universe's name within the reference request. Character stories are not necessary but are a welcomed addition for those wanting to know more about your character's existence. When creating an Avali within their universe, strict adherence to the base RyuuujinZERO's lore or this guidance is



Figure 1 - Avali NTM (left) and Todd Avali (right), conversing in a virtual avatar world found in VRChat Inc.'s "VRChat". 3D avatars "Da'Vali" from Rai Kitamatsu, photograph courtesy of NTM.

mandatory. Deviations from certain aspects of the Avali, such as diets, size, composition, and head features, are not permitted. In addition, consider creating more of a pack rather than a single Avali character, as Avali are pack based.

DESIGN

Many guides exist from a multitude of sources for the creation of a personal Avali character. In this section, there are templates available to use for the creation of an Avali character. There are some base male and female Avali character reference sheets and examples of head crests, feather patternings, tail designs, and clothing patterns. Additionally, a blank reference sheet is provided for more creative designs.

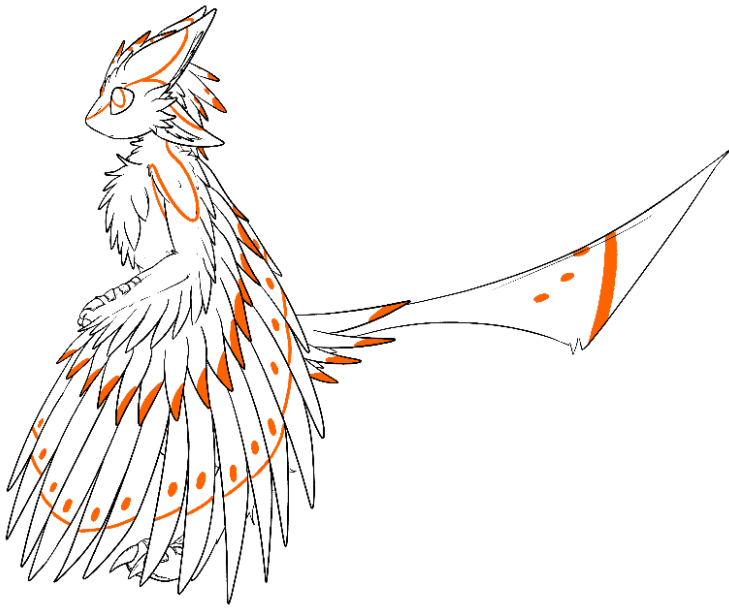

Figure 2 - Male Avali reference (top), Female Avali reference (right)

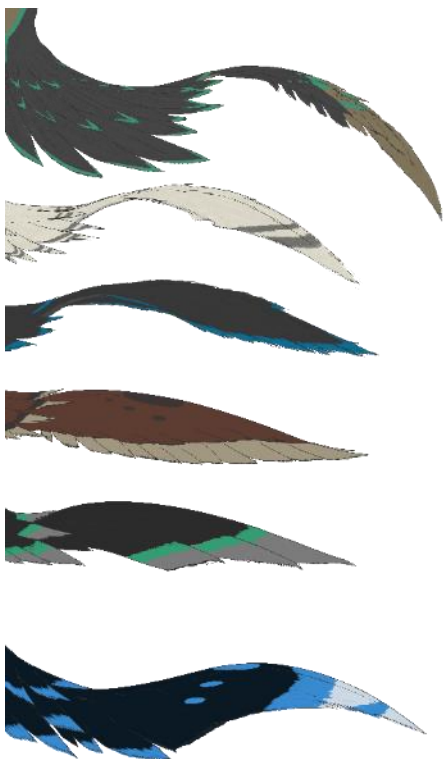

Figure 3 - Tail examples (left)





Figure 4 - Examples of feather markings

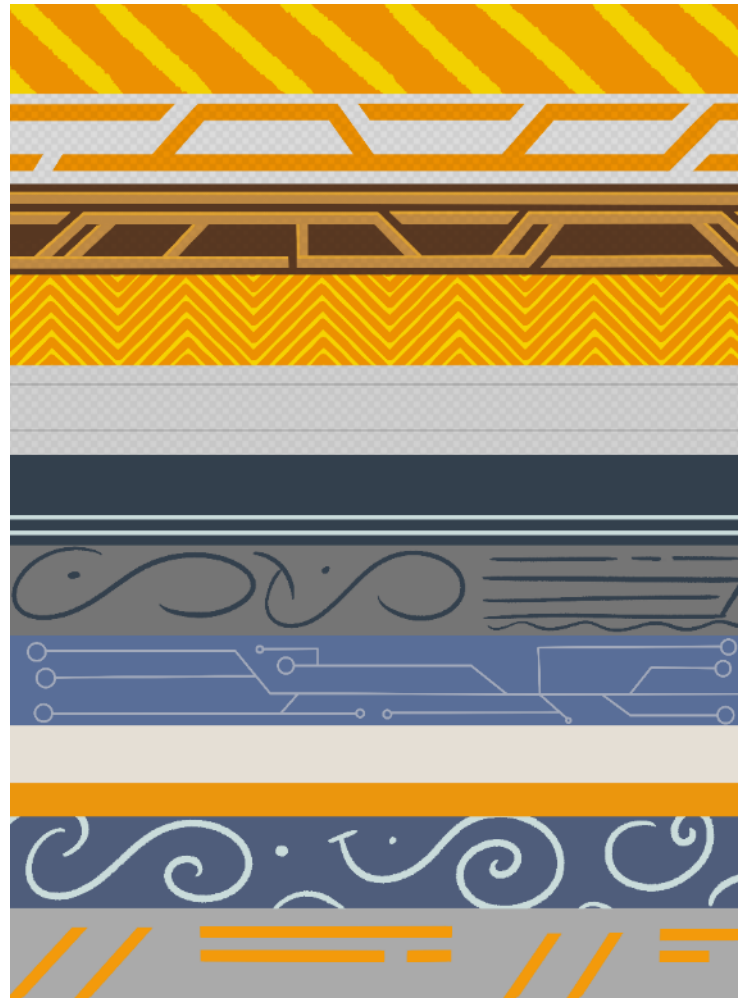

Figure 5 - Blank Avali reference sheet (left), clothing patterns (right)



Long Back



Well Kept



Kita



Falcon



Single Broad Feather



Dual Feathers



Messy



Slick Backed



Small Mohawk



Full Mohawk



Full Crest Crown



Dapper



Large Plummage



Swept Feathers



Quills



Dual Back Feathers

Figure 6 – Examples of Avali head crest styles



Figure 7 - Avali showing off feather inlays and clothing

ESTABLISHED UNIVERSES

Avali are a work of science fiction (sci-fi). As such, they are found exclusively within sci-fi-based universes, such as Chucklefish's "Starbound" or Gene Roddenberry-National Broadcasting Corporation (NBC)'s "Star Trek." Technology levels are often adjusted to meet the established requirements of these universes. Avali with FTL and warp-style spaceships is also typical, with an assortment of lore-appropriate weapons and technologies. They are often seen as explorers, with or without environmental protective gear, adventuring on alien planets. Others are spaceship captains or space soldiers defending against an established enemy.

Avali do not have to fall under any allegiance. They can be either good, bad, or neutral. Depending on your chosen avenue, their diplomacy must match what is established in that universe. Avali are seen in packs, so encounters with them must have at least three members but no more than 6. Standardly, Avali

are not strong and cannot take on a human one-on-one unless augmented. While this is the standard, adherence to it is unnecessary, as fictional universes have varying rules. Avali rely heavily on technology to give them a competitive edge in the galactic playing field. Avali can walk without the critical need for protective gear within an established universe if you choose to.

When adopting their base lore into other universes', consult the Space Exploration section of the previous chapter for diplomacy, technology level, and further details. In short, Avali are reserved, not aggressive, and have a decent technological edge against most galactic races. Avali cannot naturally speak Galactic common in whatever universe they're incorporated. Avali also cannot venture out onto preferred human planets without protective gear. Often, Avali will not be seen outside of protectorate areas or their home system of Uresk.

Incorporating Avali into settings outside of sci-fi can be done. They can be included outside the works of sci-fi and are seen in other locations, such as medieval and steampunk fantasies. These settings are commonly seen in the tabletop style of games, such as Wizards of the Coast's "Dungeons and Dragons." Avali have a set of base statistics, skills, and traits they inherently get due to their physiology and heavy adoption of technology.

Avali are flexible in whatever universe. Their open species status allows them to become a part of any lore, with alterations to their base lore. Individuals can customize their character as they see fit. When adopting all concepts of the Avali into a story, strict and careful consideration must be made. No matter which universe they participate in, crediting the original creator, RyuujiZERO, guidebook, or artist is heavily encouraged and respected.

STATISTICS AND TRAITS

Avali stats and traits capture vital aspects of an Avali and allow for the integration of the species into games and stories. These features are summarized and simplified, and referenced for additional information within this guide. Some traits also include a *downside* characteristic. Creators and players can choose to opt in for these *downsides*, if they desire. Stats and traits are used for both player and nonplayer characters (NPC). This section was written with Wizards of the Coast's "Dungeons and Dragons" 5th edition style, but stats and traits can be modified for any tabletop game. In this guide, samples of names and occupations are also provided. When reading this section, some traits and perks require multisided dice to determine modifiers for your character. When these instances happen, you will be given a sided dice number, along with how many units of dice. Standard dice sizes are 4, 6, 8, 10, 12, 20, and 100-sided. Dice sizes will be indicated

with the letter "d" followed by the side number. The quantity is provided for multiple dice before the dice size. For example, when a stat requires a single 20-sided die, it will be labeled 1D20. Additional modifiers added to the end of these rolls are indicated by a "+" or "-" after the required dice. A character's speed, which is how far a character can move during a turn or instance, is only based on 5ft increments.

Avali					
<i>Space Raptor, No Alignment</i>					
Armor Class 11					
Hit Points 12 (4D4 + 2)					
Speed 30 ft., climb 10 ft., flight 15 ft.					
STR	DEX	CON	INT	WIS	CHA
7 (-2)	10 (0)	10 (0)	10 (0)	11 (+1)	10 (+1)
Skills Stealth +4, Survival +4, Acrobatics +4					
Senses Darkvision 30 ft.,					
Languages: Avalian Core, Common					
Challenge 0					
Actions					
Ranged Attack. The Avali will attack using a ranged weapon. +4 to hit, one target.					
Pack Tactics. Avali gain an advantage when attacking within 15ft of another pack or party member.					
Aerogel Blade. <i>Melee, finesse:</i> +2 to hit, reach 5ft. one target. <i>Hit:</i> 4 (1D4 + 2) piercing, +2 for bleeding damage per turn.					

Size and speed. Avali average height is around 100-120 cm or 35-43 in. The average weight is 27-25 kg or 60-68 lbs. Their size is *Small*. Their speed is average, at *30ft*. Avali can fly, glide, and mitigate fall damage from *15ft*, and their base flight speed is *15ft*. Their base flight speed in low gravity is enhanced to *30ft*. For calculating random heights for Avali, use the following:

Base Height	Height Modifier*	Base Weight	Weight Modifier**
43 in	+2d6	60 lb.	+ 3d10 lb.

inches

*Height = base height + height modifier

**Weight = base weight + (height modifier × weight modifier)

Ability scores modifiers. Your Avali will have their *dexterity score* increased by 2 and *wisdom score* increased by 1. Their *strength* will be reduced by 2.

Age. Due to their low metabolic rate, the average lifespan of an Avali is between 200-250 years. Avali reach adulthood at 20.

Proficiencies. Avali are proficient at *stealth, survival, and perception*.

Pack tactics. Avali receive an *advantage* when performing tasks or attacking when they are *within 15ft* of their pack or party.

Nimble Space Raptors. Avali have sharp talons and claws on their feet and hands. Avali can traverse rough terrain as if it was normal, along with *scaling ledges* of no more than 10ft. Striking an opponent unarmed will deal 1D6 *plus strength* modifier slashing damage.

Worse Than Bark. In place of an unarmed strike, Avali can bite a creature within 5 feet of them, which deals 1d6 *piercing damage plus their Strength or Dexterity modifier* on a successful hit. They are considered proficient in this attack.

Fluffy Bodies. Avali are acclimated to Extreme Cold, and you have an *advantage* on Survival checks while in terrains such as tundras and other cold places. Additionally, they are *resistant to cold and ice attacks*. *Downside:* They have a more challenging time in hot spots like deserts and the tropics. Avali have a *survival disadvantage* in these and are *weak to fire and water damage*.

Predator's Hearing. Avali have two pairs of ears that can detect an extensive range of sound

frequencies. They are also able to use echolocation and navigate in *complete darkness*. Avali have an *advantage in Perception* that relies on hearing.

Physical Characteristics. Avali are feathered creatures, and their patternings are simple. Roll 1D6 for patterns, odds for males and evens for females, 1D100 for pattern accent colors, and 2D100 for base colors. Note that you do not have to abide by this and can create your desired Avali.

1D6 FEATHER PATTERN

1	Single Stripe
2	Spotted
3	Chevrons
4	Speckled
5	Chevrons and Dot
6	Chevrons and Speckles

1D100 PATTERN COLOR

1-9	Green
10-19	Red
20-35	White
36-45	Blue
46-55	Tan
56-65	Black
66-75	Grey
76-85	Purple
86-94	Yellow
95-100	Gold

1D100 THE BASE COLOR (ROLL FOR 2)

1-15	Grey
16-25	Dark Grey
26-35	Black
36-45	White
46-60	Light grey
61-75	Tan
75-85	Green
86-95	Brown-orange
91-95	Blue
96-100	Yellow

Weakened Eyesight. Avali can see in dim light out to 30 feet as if it were bright light and in near darkness as if it were dim light, thanks to their *infrared* vision. *Downside:* They are nearsighted, with slight difficulties discerning fine objects without some aid. Avali have a *disadvantage* on all perception checks involving sight.

Obligate Carnivores. *Downside.* Avali are only able to consume animal meat and products. Eating foods that do not fall within their carnivore diets will result in them taking *1D4+2 poison damage*, rolled each turn or when 1-minute elapses, for 1 hour.

Ammonia and Water. Avali can drink cold ammonia and super chilled water. A *dedicated flask* is added to their inventory for this. *Downside:* Drinking warm water or ammonia will cause *burning damage of 3D6* for 1 minute or 1 turn.

Encounters. When encountering Avali, they will be in packs of 2 or more. Roll 1D6 to determine pack size and 1D4 for numbers 1 and 2. Avali will often be armed with ranged weaponry and avoid melee encounters if possible.

Tribes and colonies. When encountering Avali tribes and colonies, they often consist of a main common tent, usually at the center of the camp. Hatcheries are next to these tents. A central kitchen and eating tent will also be close to the center. Surrounding the center will be various tents of hunters, crafters, merchants, and stockpiles. For more stationary buildings, they are often made from metal and aerogel. Creatures larger than small will have a hard time entering all Avali structures. These tribes and colonies are found in cold areas of the world, near hunting grounds. Others are outposts for resource gathering. Tent-based locations will move from their initial discovering point after a couple of weeks, so returning to the camp might not be a valid option.

Goods and Services. Avali specialize in technology, discovery, and hunting. Goods will often be high-end tech, maps, processed meats, and animal products. Weapons are typically not traded to foreigners. Pets and other animals are also not sold and often are rare to find to begin with, outside of cattle. Artisans are very common and can offer specialized jewelry, works of art, and music pieces. When hiring Avali for work, remember that you are hiring a pack of Avali between 3-6 members, not just 1.

Allies and Enemies. Avali are reserved and generally peaceful. They are usually allied with nearby villages, colonies, and cities for trade and sustenance. Their reservations leave them with few enemies outside the standard bandits, pirates, and aggressive animals. Avali tribes and colonies will often avoid making alliances with foreign parties unless some major benefit can come from it.

Names. The first names of Avali do not follow any naming scheme but are personalized to the individual Avali. The last names are pack names, usually denoting some role or job. Ancient pack names also include characteristics of the pack, such as feather color. The following are some examples of first and last names:

First names: Eikuni, Einuni, Jasko, Tasako, Jesuli, Nali, Runo, Halun, Nauko, Khauni, Kazun, Jasun, Rhauni, Kala, Ranani, Eijani, Nuko, Kalali, Eili, Rala, Halun, Nezumi, Romi, Eikuno, Kasumi, Renuno, Kala, Khaan, Nahomi, Eito, Eijomi, Renomi, Romi, Naomi, Rhauli, Jesumi, Eikyo, Kali, Nali, Renii, Rali, Einala, Ruli, Rali, Nezyo, Kasaku, Rani, Rhaoli, Einali, Ryu, Eino, Jesan, Nezomi, Jasi, Kali, Ranuni, Ranan, Talomi, Kuli, Eijuli, Kasa, Reno, Talyu, Nako, Ranami, Khaali, Nesun, Kaso, Jesami, Eito, Nezumi, Jasoli, Rako, Rhaun, Naumi, Rhaoli, Rhaaku, Ranuno, Rano, Eilan, Nauli, Eikaka, Rali, Ialii, Eikuko, Renuli, Rhaii, Raluni, Nzuno, Jasuli, Ranuni, Ralako, Jesaka, Halaku, Renan, No, Eitala, Ruli, Nahuko, Rumi, Renani, Taluko, Eikomi, Khaumi, Renani,

Taluko, Eitali, Eitali, Eikali, Eityu, Nauno, Jasoli, Kalali, Ralun, Jesyo, Nai, Kasoli, Hala, Kyo, Kalumi, Jasomi, Eitun, Hali, Taloli, Ran, Jesali, Renuli, Kasyu, Eilyo, Nahumi, Kala, Kuko, Talaka, Talo, Eityu, Kan, Zexii, Khauko, Eilun, Renyu, Kazan, Raloli, Nezyo, Jasuko, Nami, Kasyu, Rana, Eitii, Kalani, Naka, Nezo, Halaka, Tali, Nomi, Eijuno, Rhao, Naako, Eikako, Halami, Eiki, Nezako, Khao, Khauno, Jesaku, Kaluni, Rhaa, Haluli, Raloli, Numi, Talako, Jasoli, Kasala, Khaumi, Ka, Kan, Rhaomi, Talun, Halala, Koli, Einjuni, Kazyo, Naih, Eitumi, Nahyu, Nahuni, Kazii, Nahaku, Eilaku, Nahyu, Nahuni, Eijuli, Kazuli, Nasala, Rhao, Jesoli, Nahani, Nan, Kalo, Rhaako, Jasyu, Eitami, Eita, Nezi, Kazo, Jasa, Nahomi, Nezyo, Nuno, Ru, Kun, Talan, Naaku, Zieh

Last names: Mineclaw, Ironclaw, Irontalon, Darkfeathers, Silverfeather, Hatchguard, Hunter, Aviator, Sprinter

Note: names with otherwise unpronounceable letters will be treated as such:

- F's are pronounced with a "kjrr" sound.
- J's are pronounced with a "yah" sound.
- N's are pronounced with an "h" sound.
- V's are short pauses indicated with a '.

Combat Armored Avali					
<i>Space Raptor Fighter, Chaotic Neutral</i>					
Armor Class 18					
Hit Points 14 (4D4 + 2)					
Speed 30 ft., climb 10 ft.					
STR	DEX	CON	INT	WIS	CHA
9 (-1)	15 (+3)	12 (+1)	10 (0)	15 (+3)	11 (0)
Skills Stealth +4, Survival +4, Acrobatics +4					
Senses Darkvision 60 ft., Enhanced hearing 120ft., passive Perception 12					
Languages: Avalian Core, Common					
Challenge 3					
Helmet Enhancements. Combat armor helmets provide an enhanced sighting system, negating the disadvantages of sight-based Perception rolls.					
Heavier than Normal. Due to the combat armor, flight is no longer possible for the Avali.					
Actions					
Ranged Attack. The Avali will attack using a ranged weapon. +4 to hit, one target.					
Pack Tactics. Avali gain an advantage when attacking within 15ft of another pack or party member.					
Aerogel Blade. <i>Melee, finesse:</i> +2 to hit, reach 5ft. one target. <i>Hit:</i> 4 (1D4 + 2) piercing, +2 for bleeding damage per turn.					

Arcane Avali					
<i>Space Raptor Sorcerer, Chaotic Neutral</i>					
Armor Class 12					
Hit Points 11 (4D4 + 2)					
Speed 30 ft., climb 10 ft., flight 15ft.					
STR	DEX	CON	INT	WIS	CHA
7 (-2)	10 (0)	13 (+2)	10 (0)	12 (+2)	10 (0)
Skills Stealth +4, Arcana +4					
Senses Darkvision 30 ft., Enhanced hearing 120ft., passive Perception 12					
Languages: Avalian Core, Common					
Challenge 3					
<p>Spellcasting. Arcane Avali is a 3rd level spellcaster. Its spellcasting ability is Constitution (spell save DC13, +4 to hit with spell attacks). The following are spells prepared:</p> <p>Cantrips (at will): <i>minor illusion, poison spray, frostbite, ray of frost</i></p> <p>1st level (4 slots): <i>comprehend languages, expeditious retreat, sleep, Ice Knife</i></p> <p>2nd level (2 slots): <i>gust of wind, darkness</i></p>					
<p>Sorcery Points. Arcane Avali has 3 sorcery points. It can spend 1 or more sorcery points as a bonus action to gain the following benefits:</p> <p><i>Heightened Spell.</i> When it casts a spell that forces a creature to make a saving throw to resist the spell's effects, the Avali can spend 3 sorcery points to give one target of the spell disadvantage on its first saving throw.</p> <p><i>Subtle Spell.</i> When the Avali casts a spell, it can spend 1 sorcery point to cast the spell with any somatic or verbal components.</p>					
Actions					
<p>Pack Tactics. Avali gain an advantage when attacking within 15ft of another pack or party member.</p>					
<p>Aerogel Blade. <i>Melee, finesse:</i> +2 to hit, reach 5ft. one target. <i>Hit:</i> 4 (1D4 + 2) piercing, +2 for bleeding damage per turn.</p>					

Additional NPC Archetypes

Avali Bard					
<i>Space Raptor Bard, Chaotic Good</i>					
Armor Class 12					
Hit Points 14 (4D4 + 3)					
Speed 30 ft., climb 10 ft., flight 15ft.					
STR	DEX	CON	INT	WIS	CHA
7 (-2)	12 (+1)	10 (0)	11 (0)	13 (+2)	14 (+2)
Skills Stealth +4, Performance +4, Acrobatics +4					
Senses Darkvision 30 ft., Enhanced hearing 120ft., passive Perception 12					
Languages: Avalian Core, Common					
Challenge 3					
<p>Spellcasting. The Avali bard is a 4th level spellcaster. Its spellcasting ability is Charisma (spell save DC13, +4 to hit with spell attacks). The following spells are prepared:</p> <p>Cantrips (at will): <i>dancing lights, minor illusion, vicious mockery, mending</i></p> <p>1st level (4 slots): <i>comprehend languages, charm person, detect magic, earth tremor</i></p> <p>2nd level (4 slots): <i>calm emotions, cloud of daggers, blindness/deafness, crown of madness</i></p> <p>3rd level (2 slots): <i>fear, dispel magic</i></p>					
Actions					
<p>Pack Tactics. Avali gain an advantage when attacking within 15ft of another pack or party member.</p>					
<p>Aerogel Blade. <i>Melee, finesse:</i> +2 to hit, reach 5ft. one target. <i>Hit:</i> 4 (1D4 + 2) piercing, +2 for bleeding damage per turn.</p>					

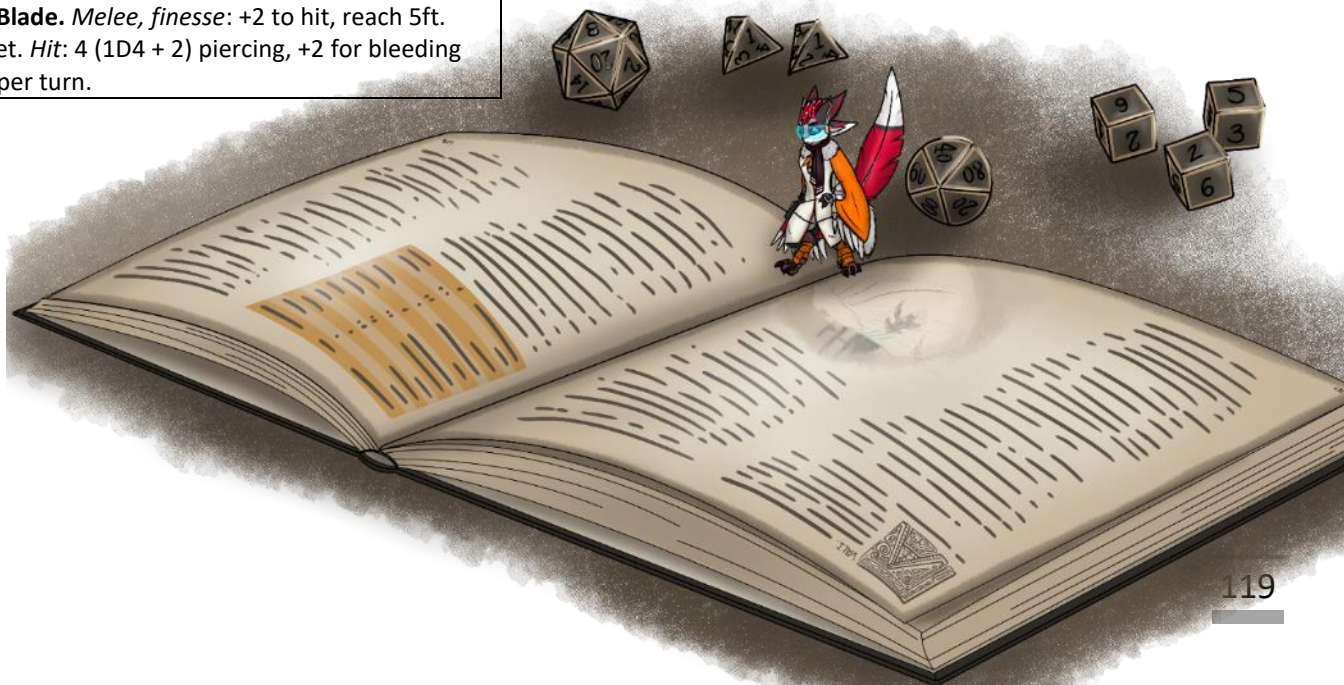

STARBOUND UNIVERSE

The Avali race was created as a playable alien race, modded in by RyuujinZERO. A widespread introduction to the Avali race stems from the Chucklefish video game known as “Starbound.” You can create a personal Avali character and experience the story and game as this character. Most interactions with the world have been modified to fit the Avali mindset and culture. Other aspects of the game have been left unchanged, such as the story and quests.

Experiencing the story of “Starbound” is the same, regardless of which race you play. Your Avali character is a surviving member of the Galactic Protectorate. You explore a section of the galaxy to unlock clues to find the boss that killed off the Protectorate. The story itself is rudimentary. Alongside the main story, short escort and fetch quests add more gameplay to the game. The already established list does quests given by Avali NPCs within “Starbound” in the base game. Unlike the lore, your Avali is alone, and you must recruit crew members to replicate some form of pack.

Avali-specific gear, buildings, and objects are added in through the base Ryuujin mod. Many new clothing and armor apparel styles have been created for use and wear. While none of the armor adds new stats to your character, the gear gives an Avali something to wear, as the base clothing and armor do not appear on the Avali. In addition to the apparel, new placeable blocks and furniture have also been added to the game. These blocks mimic some of the artistic styles that Avali have developed, with sleek and modern stationary buildings and intricately woven fabrics and tents. Players can build creations and encounter generated Avali colonies and outposts on other planets. In addition, a new spaceship created from these blocks is provided. Furniture sets

and creating stations have received the same treatment, with new beds, chairs, tables, and appliances all functional and added to the game.

New materials for the game were also added based on the Avali lore. Players can weave graphene and print orange aerogel. These materials are used to create Avali-specific furniture, tools, and weapons. The base game’s supplies manufacture these materials, so finding reliable sources of supply to create Avali décor is not needed. Edible plant materials were also added to enable Avali to craft specific cuisines.

Unlike their base lore, Avali can explore many worlds without needing an environmental protective suit. Protection is tied to the base game, only necessary to progress the story. Avali camps and colonies will often spawn on warm jungles or temperate planets, disregarding the temperature. Additionally, Avali are not bound to their carnivore diets, able to consume all base game foodstuffs. These deviations are often attributed to their augments, allowing them to live, explore, and eat in locations that would otherwise be prohibitive.

AVALI OUTSIDE OF STARBOUND

Avali have been seen in many video games and media outside Chucklefish's "Starbound" and their origin game, the EA-Maxis' "Spore." The race has been modded or written in ways to adapt to its new universe. Many Avali are seen as digital 3D avatars used for socializing. Arts, books, and other media sources have also been generated, becoming popular on the internet. As such, a small community of dedicated people has gathered, creating a fandom surrounding the race.

The most significant and most common form of Avali found outside of "Starbound" is in the use of 3D avatars. Artists and sculptors have created a large selection of unique-looking Avali avatars that are customizable to the individual. These Avatars are used in multiple forms of media. Commonly, the Avali avatars are seen in virtual chat programs, such as VRChat Inc. "VRChat," Alpha Blend Interactive's "ChilloutVR," and Frooxius' "Resonite." People wearing these avatars interact with others online in a nearly anonymous way. Avali often gather together in these instances as a common interest group or even a pseudo-pack. Avatars

are also used in entertainment, with entertainers wearing

the digital avatar and entertaining others through the internet and live-action videos, also known as "streaming." 3D sculptures can also create short films or movies with avatars to provide additional entertainment. Sculptures and artists have created many unique items for Avali avatars to wear, coupled with unique designs to set each Avali individual apart.

Videogames that feature playable alien races will find the Avali race modded into the game. Games like Paradox's "Stellaris" allows players to create a galactic alien empire using the Avali race as a mod. Other intense games like Ludeon Studio's "Rimworld" puts the player as a colony manager. Avali mods add the race to the game and item sets that can be used, complimenting the race. Most other games are straightforward with their implementation of the Avali race into the game, with most simply replacing the primary character model with an Avali one. While possible, these games lack feature sets that would make the Avali much more immersive, such as moving tails and ears.

Tabletop Games have seen some adoption of the Avali race. The race is community generated, like a video game mod, and can be used by anyone. Games such as Jason Tocci's "24XX" and Wizards of the Coast's "Dungeons and Dragons" have unique statistics and traits that apply to the race, allowing



Figure 1 – Examples of the "Ja'Vali". 3D avatar and photos by Javenchi.

them to become more incorporated into the universe. Unlike video games, these games usually require a physical presence of all players, with calculations and role-playing aspects being more analog.

The small Avali community outside of the entertainment realm exists today. Initially formed in the early “Starbound” days, the Avali community has grown, featuring artists, writers, musicians, and general fans, all sharing the same interest in the Avali race. These fans are found worldwide and from multiple different backgrounds. The internet has allowed the community to come together and share their interests, artworks, and entertainment media.

Figure 2 – Example of the “[Rosa’Vali](#)”. 3D Avatar and photo by Rosebur.



CHAPTER SUMMARY

The creation of a personal Avali character is easy to do. Avali are found to be very cute amongst many individuals. Many resources and artists exist that can make an individual character come to life. This book reviewed many vital aspects and traits of the Avali race, and not all these characteristics have to be strictly followed. The Avali race and concepts, as created by RyuujinZERO, are open to many variations without the need for strict adherence to the base lore of this book.

Integrating an Avali character or the entire race into a universe adds a unique set of challenges to be overcome. The race can fall into any universe as needed, with ordinarily only slight adjustments to the race itself. This book offers some baseline statistics and traits that Avali must help integrate the race or character more easily into any universe.

The Avalian race has evolved beyond its roots, finding itself in various mediums. Multiple entertainment forms exist for Avali. A small community of fans has formed, creating multiple universe editions for games, entertainment, and artworks.



Figure 1 – Misty Jinn playing in a “VRChat” world. 3D Avatar is the “Jerry’Vali” created by Rai Kitamatsu. Photograph courtesy of Misty Jinn (top). “Ja’vali” Avatar and render by Javenchi (left).

RESOURCES AND CONTACTS

Justin R. Eckelbarger

Todd "To'Vali" Avali
 Author, Project Lead, Lead Artist
 Contact via the following:
 Email: toddeckel2010@gmail.com
 Discord: Toddtheavali

A. Hagermann, P. R. (2007, August 1). *Speed of sound measurements and the methane abundance in Titan's atmosphere*. Retrieved from <https://www.sciencedirect.com>: <https://www.sciencedirect.com/science/article/pii/S0019103507000887>

American Meteorological Society. (2022, November 2). *Radioactive Gas*. Retrieved from <https://glossary.ametsoc.org>: https://glossary.ametsoc.org/wiki/Radioactive_gas

Bensch, J.-Å. N. (2022, May 01). *Journal of Avian Biology*. Retrieved from <https://onlinelibrary.wiley.com>: <https://onlinelibrary.wiley.com/journal/1600048x>

Birdwatching Bliss. (2022, November 8). *Bird Reproduction & Anatomy*. Retrieved from <https://www.birdwatching-bliss.com>: <https://www.birdwatching-bliss.com/bird-reproduction.html>

Chen, M. Z. (2001, November 23). *Reactions of silicon dioxide with ammonia molecules*. Retrieved from <https://www.sciencedirect.com>: <https://www.sciencedirect.com/science/article/abs/pii/S0009261401011927>

Christine Larkins, M. G. (2014, August 1). *Evolution of External Genitalia*.

Retrieved from <https://www.researchgate.net>: https://www.researchgate.net/publication/264797248_Evolution_of_External_Genitalia_Insights_from_Reptilian_Development

David, R. &. (2009, June 1). *Huygens' measurements of the speed of sound on Titan*. Retrieved from <https://articles.adsabs.harvard.edu>: <https://articles.adsabs.harvard.edu/full/seri/Obs../0129/0000106.000.html>

Davis, P. (2022, November 03). *Moons: Active Worlds*. Retrieved from <https://solarsystem.nasa.gov>: https://solarsystem.nasa.gov/resources/2475/moons-active-worlds/?category=moons/saturn-moons_titan

Davis, P. (2022, November 03). *Titan*. Retrieved from <https://solarsystem.nasa.gov>: <https://solarsystem.nasa.gov/moons/saturn-moons/titan/in-depth/>

Dodd, S. (2022, November 03). *Titan: Exploration*. Retrieved from <https://solarsystem.nasa.gov>: https://solarsystem.nasa.gov/moons/saturn-moons/titan/exploration/?page=0&per_page=10&order=launch_date+desc%2Ctitle+asc&search=&tags=Saturn&category=33#dutch-astronomer-christiaan-huygens-discovers-titan

Dorit, W. &. (1991). *Zoology*. Orlando, Florida, United States: Saunders College Publishing.

Elemtilas. (2017, September 9). *What impact would copper-based blood (haemocyanin) have on a humanoid creature?* Retrieved from <https://worldbuilding.stackexchange.co>

- m:
<https://worldbuilding.stackexchange.com/questions/91336/what-impact-would-copper-based-blood-haemocyanin-have-on-a-humanoid-creature>
- Fandom.com. (2022, November 1). *F-type Main-Sequence Star*. Retrieved from https://astronomy.fandom.com:https://astronomical.fandom.com/wiki/F-type_main-sequence_star
- Gast, R. (2021, July 13). *Warp Drive Leads to New Physics*. Retrieved from <https://www.scientificamerican.com:https://www.scientificamerican.com/article/star-treks-warp-drive-leads-to-new-physics/>
- Gredler M., L. C. (2014, September 1). *Evolution of External Genitalia: Insights from Reptilian Development*. Retrieved from <https://www.karger.com:https://www.karger.com/Article/Fulltext/365771#>
- Hadhazy, A. (2014, March 1). *Could Alien Life Cope with a Hotter, Brighter Star?* Retrieved from <https://www.space.com:https://www.space.com/25716-alien-life-hotter-stars.html>
- Haipeng Zhao, J. C. (2015, October 14). *Solubility of Calcium Carbonate in Ammonium Chloride Aqueous Solution at T = (298.15, 323.15, and 348.15) K*. Retrieved from <https://pubs.acs.org:https://pubs.acs.org/doi/abs/10.1021/acs.jced.5b00417>
- Igor Pastirk, M. C. (2001, November 23). *Femtosecond ground state dynamics of gas phase N2O4 and NO2*. Retrieved from <https://www.sciencedirect.com:https://www.sciencedirect.com/science/article/abs/pii/S0009261401011071>
- International Nuclear Information System. (1975, February 12). *Radioactive Gases*. Retrieved from https://inis.iaea.org:https://inis.iaea.org/search/search.aspx?orig_q=RN:8321656
- James F. Collins, J. R. (2010, Mar 6). *Metabolic Crossroads of Iron and Copper*. Retrieved from <https://www.ncbi.nlm.nih.gov:https://www.ncbi.nlm.nih.gov/pmc/articles/PMC3690345/>
- Javenchi. (2023, Dec 23). <https://javenchiart.carrd.co/>. Retrieved from Javenchi Art: <https://javenchiart.gumroad.com/>
- Jun, J. W. (1969, November 15). *Ammonia and Biological Deposition of Calcium Carbonate*. Retrieved from <https://www.nature.com:https://www.nature.com/articles/224725a0>
- Kitamatsu, R. (2022, November 7). *Rai Kitamatsu Gumroad*. Retrieved from <https://raikitamatsu.gumroad.com:https://raikitamatsu.gumroad.com/>
- L.A. Stowe, C. B. (1998, September 14). *Localizing components of a complex task: sentence processing and working memory*. Retrieved from <https://pubmed.ncbi.nlm.nih.gov:https://pubmed.ncbi.nlm.nih.gov/9804304/>
- Larkins, C. (2014, August 01). *Alternative Scenarios for Evolution of Amniote External Genital Morphogenesis*. Retrieved from <https://www.researchgate.net:https://www.researchgate.net/figure/A>

- D-Alternative-scenarios-for-the-evolution-of-amniote-external-genital-morphogenesis_fig3_264797248
- Larkins, C. (2014, August 1). *Embryonic Amniote Cloacal Anatomy*. Retrieved from <https://www.researchgate.net>: https://www.researchgate.net/figure/Embryonic-amniote-cloacal-anatomy-Schematic-drawing-of-the-developing-amniote-cloaca-and_fig4_264797248
- Larkins, C. (2014, August 1). *Genital Development*. Retrieved from <https://www.researchgate.net>: https://www.researchgate.net/figure/Scanning-electron-micrographs-of-amniote-external-genital-development-Morphogenesis-of_fig2_264797248
- Larsen, D. (2012, November 2). *Phonetics*. Retrieved from <https://udel.edu>: <https://udel.edu/~dlarsen/ling101/slides/Phoneticshandout.pdf>
- Lueptow, A. P. (2007, February 1). *Atmospheric acoustics of Titan, Mars, Venus, and Earth*. Retrieved from <https://www.sciencedirect.com>: <https://www.sciencedirect.com/science/article/pii/S0019103506003381>
- Mary Ann Clark, J. C. (2022, November 2). *Biology 2e*. Retrieved from <https://openstax.org>: <https://openstax.org/books/biology-2e/pages/preface>
- Nancy Merino, H. S.-B. (2019, April 9). *Living at the Extremes: Extremophiles and the Limits of Life in a Planetary Context*. Retrieved from <https://www.researchgate.net>: https://www.researchgate.net/publication/332434360_Living_at_the_Extremes_Extremophiles_and_the_Limits_of_Life_in_a_Planetary_Context
- NASA. (2022, October 31). *What is Gravity*. Retrieved from <https://spaceplace.nasa.gov>: <https://spaceplace.nasa.gov/what-is-gravity/en/>
- National Aeronautical and Space Administration. (2021, March 3). *Goldilocks Zone*. Retrieved from <https://exoplanets.nasa.gov>: <https://exoplanets.nasa.gov/resources/323/goldilocks-zone/>
- National Aeronautics and Space Administration. (2018, July 30). *Top Five Technologies Needed for a Spacecraft to Survive Deep Space*. Retrieved from <https://www.nasa.gov>: <https://www.nasa.gov/feature/top-five-technologies-needed-for-a-spacecraft-to-survive-deep-space>
- National Aeronautics and Space Administration. (2022, November 2). *Solar System and Beyond*. Retrieved from <https://www.nasa.gov>: <https://www.nasa.gov/content/stars-and-galaxies>
- National Aeronautics and Space Administration. (2022, January 27). *Tales From the Deep Earth*. Retrieved from <https://astrobiology.nasa.gov>: <https://astrobiology.nasa.gov/news/tales-from-the-deep-earth/>
- National Air and Space Museum. (2022, November 03). *Titan - A Moon With An Atmosphere*. Retrieved from <https://airandspace.si.edu>: <https://airandspace.si.edu/exhibitions/exploring-the-planets/online/solar-system/saturn/titan.cfm>
- National Geographic. (2022, November 02). *Carnivore*. Retrieved from <https://education.nationalgeographic.com>

- rg:
<https://education.nationalgeographic.org/resource/carnivore>
- Navid Seraji-Bzorgzad, D. A. (2012, January 1). *Complex Cognitive Task*. Retrieved from <https://www.sciencedirect.com>:
<https://www.sciencedirect.com/topics/psychology/complex-cognitive-task>
- Nidoran, J. T. (2022, November 7). *24XX Avali*. Retrieved from <https://nidoran.itch.io>:
<https://nidoran.itch.io/24xx-avali-rpg>
- Physics Classroom. (2022, November 1). *Sound*. Retrieved from <https://www.physicsclassroom.com>:
<https://www.physicsclassroom.com/classes/sound/u11l1c.cfm>
- Picot, W. (2022, February 18). *Nuclear Technology Set to Propel and Power Future Space Missions, IAEA Panel Says*. Retrieved from <https://www.iaea.org>:
<https://www.iaea.org/newscenter/news/nuclear-technology-set-to-propel-and-power-future-space-missions-iaea-panel-says>
- Rosebur. (2023, Dec 21). <https://rosebur.com/>. Retrieved from <https://rosebur.com>:
<https://rosebur.gumroad.com/>
- Rosenberg, P. D. (2009, January 1). *Huygens' measurements of the speed of sound on Titan*. Retrieved from <https://www.researchgate.com>:
https://www.researchgate.net/publication/253630528_Huygens%27_measurements_of_the_speed_of_sound_on_Titan
- RR Fay, D. W. (1994, November 1). *How Well Do Dogs and Other Animals Hear*. Retrieved from <https://www.lsu.edu>:
<https://www.lsu.edu/deafness/HearingRange.html>
- RyuujinZERO. (2009, July 19). *Ryuujin's Creations*. Retrieved from www.spore.com:
<http://www.spore.com/sporepedia#qry=usr-Ryuujin%7C2262881868%3Apg-40>
- RyuujinZERO. (2013, December 14). *Ryuujin's Stuff*. Retrieved from <https://community.playstarbound.com>:
<https://community.playstarbound.com/threads/ryuujins-stuff-chronicles-of-a-custom-race.52382/#post-1608287>
- RyuujinZERO. (2014, Jan 06). *Meet the Avali*. Retrieved from <https://community.playstarbound.com>:
<https://community.playstarbound.com/threads/meet-the-avali-original-and-fluffy.62945/>
- RyuujinZERO. (2016, August 11). *Avali 1.0 Reboot Discussion*. Retrieved from <https://community.playstarbound.com>:
<https://community.playstarbound.com/threads/avali-1-0-reboot-discussion.122117/>
- RyuujinZERO. (2019, December 30). Official Avali Discord Server. *Avali Discord Server*, 50-91. N/A, N/A, N/A: Discord.
- RyuujinZERO. (2019, December 30). *The Official Avali Wiki*. Retrieved from <https://avali.fandom.com>:
https://avali.fandom.com/wiki/The_Official_Avali_Wiki
- Schempp, E. (2007, December 15). *Gravity: Its Only a Theory*. Retrieved from <https://ncse.ngo>:
<https://ncse.ngo/gravity-its-only-theory>
- Smith, D. (2005, April 5). *The Dromaeosauridae*. Retrieved from UCMP Berkeley:
<https://ucmp.berkeley.edu/diapsids/saurischia/dromaeosauridae.html>

- Steven E. Jasinski, R. M. (2020, March 26). *New Dromaeosaurid Dinosaur (Theropoda, Dromaeosauridae) from New Mexico and Biodiversity of Dromaeosaurids at the end of the Cretaceous*. Retrieved from <https://www.nature.com>: <https://www.nature.com/articles/s41598-020-61480-7>
- Stevenson, D. J. (2012, November 2). *Fluctuating Gravity of Earth's Core*. Retrieved from <https://www.pnas.org>: <https://www.pnas.org/doi/10.1073/pnas.1216731109>
- Stromberg, J. (2013, June 6). *Scientists Discover the Genetic Reason Why Birds Don't Have Penises*. Retrieved from www.smithsonianmag.com: <https://www.smithsonianmag.com/science-nature/scientists-discover-the-genetic-reason-why-birds-dont-have-penises-94130874/>
- Szczegielniak, A. (2012, November 2). *Introduction to Linguistic Theory*. Retrieved from <https://scholar.harvard.edu>: <https://scholar.harvard.edu/files/adam/files/phonetics.ppt.pdf>
- The Editors of Encyclopaedia Britannica. (2022, August 18). *Human Digestive System*. Retrieved from <https://www.britannica.com>: <https://www.britannica.com/science/human-digestive-system#ref45305>
- The Editors of Encyclopaedia Britannica. (2022, November 2). *Phoneme*. Retrieved from <https://www.britannica.com>: <https://www.britannica.com/topic/phoneme>
- The Editors of Encyclopaedia Britannica. (2022, November 02). *cloaca*. Retrieved from <https://www.britannica.com>: <https://www.britannica.com/science/cloaca>
- The European Space Agency. (2004, October 21). *The Sounds of Titan*. Retrieved from <https://www.esa.int>: https://www.esa.int/Science_Exploration/Space_Science/Cassini-Huygens/The_sounds_of_Titan
- Tiina Kirsipuu, A. Z. (2020, March 30). *Copper(II)-binding equilibria in human blood*. Retrieved from <https://www.nature.com>: <https://www.nature.com/articles/s41598-020-62560-4>
- Turner, D. (2017, April 10). *Some Questions About Dinosaur Hips*. Retrieved from www.extinctblog.org: <http://www.extinctblog.org/extinct/2017/4/8/stasis-and-change-in-dinosaur-hips>
- V.V. Zagorskii, S. I. (1999, October 6). *Cryochemical synthesis and physical-chemical properties of nano-dispersed metallopolymers*. Retrieved from <https://www.sciencedirect.com>: <https://www.sciencedirect.com/science/article/abs/pii/S0965977399002536>
- Vyacheslav M. Zobin, J. Ž. (1994, November 1). *Seismicity*. Retrieved from <https://www.sciencedirect.com>: <https://www.sciencedirect.com/topics/earth-and-planetary-sciences/seismicity>
- White, T. L. (2004, July 30). *The sound of Titan*. Retrieved from <https://resource.isvr.soton.ac.uk>: <https://resource.isvr.soton.ac.uk/staff/pubs/PubPDFs/Pub2616.pdf>
- Wikipedia.org. (2007, November 2). *Earth's Atmosphere*. Retrieved from <https://www.cs.mcgill.ca>: <https://www.cs.mcgill.ca/~wwhite/earth-atmosphere/>

- https://www.cs.mcgill.ca/~rwest/wikispedia/wpcd/wp/e/Earth%2527s_atmosphere.htm
- Wikipedia.org. (2021, March 21). *Magnetic field oscillating amplified thruster*. Retrieved from https://en.wikipedia.org:https://en.wikipedia.org/wiki/Magnetic_field_oscillating_amplified_thruster
- Wikipedia.org. (2022, October 26). *Achillobator*. Retrieved from <https://en.wikipedia.org:2022>
- Wikipedia.org. (2022, October 27). *Atrociraptor*. Retrieved from <https://en.wikipedia.org:https://en.wikipedia.org/wiki/Atrociraptor>
- Wikipedia.org. (2022, November 9). *A-Type Main Sequence Star*. Retrieved from https://en.wikipedia.org:https://en.wikipedia.org/wiki/A-type_main-sequence_star
- Wikipedia.org. (2022, October 24). *Carnivore*. Retrieved from <https://en.wikipedia.org:https://en.wikipedia.org/wiki/Carnivore>
- Wikipedia.org. (2022, October 29). *Circumstellar habitable zone*. Retrieved from https://en.wikipedia.org:https://en.wikipedia.org/wiki/Circumstellar_habitable_zone
- Wikipedia.org. (2022, September 14). *Copper in Biology*. Retrieved from https://en.wikipedia.org:https://en.wikipedia.org/wiki/Copper_in_biology
- Wikipedia.org. (2022, September 25). *Dakotaraptor*. Retrieved from <https://en.wikipedia.org:https://en.wikipedia.org/wiki/Dakotaraptor>
- Wikipedia.org. (2022, November 2). *Deinonychus*. Retrieved from <https://en.wikipedia.org:http://en.wikipedia.org/wiki/Deinonychus>
- Wikipedia.org. (2022, November 02). *Dromaeosauridae*. Retrieved from <https://en.wikipedia.org:https://en.wikipedia.org/wiki/Dromaeosauridae>
- Wikipedia.org. (2022, June 16). *Dromaeosaurinae*. Retrieved from <https://en.wikipedia.org:https://en.wikipedia.org/wiki/Dromaeosaurinae>
- Wikipedia.org. (2022, September 27). *Dromaeosaurus*. Retrieved from <https://en.wikipedia.org:https://en.wikipedia.org/wiki/Dromaeosaurus>
- Wikipedia.org. (2022, November 9). *G-type Main-Sequence Star*. Retrieved from https://en.wikipedia.org:https://en.wikipedia.org/wiki/G-type_main-sequence_star
- Wikipedia.org. (2022, October 28). *Hall-effect thruster*. Retrieved from https://en.wikipedia.org:https://en.wikipedia.org/wiki/Hall-effect_thruster
- Wikipedia.org. (2022, November 2). *Interstellar travel*. Retrieved from https://en.wikipedia.org:https://en.wikipedia.org/wiki/Interstellar_travel
- Wikipedia.org. (2022, November 5). *Magnetoplasmadynamic thruster*. Retrieved from <https://en.wikipedia.org:https://en.wikipedia.org:https://en.wikipedia.org>

- https://en.wikipedia.org/wiki/Magneto_plasmadynamic_thruster
- Wikipedia.org. (2022, November 5). *Spacecraft propulsion*. Retrieved from https://en.wikipedia.org:https://en.wikipedia.org/wiki/Spacecraft_propulsion
- Wikipedia.org. (2022, November 9). *Stellar Classification*. Retrieved from https://en.wikipedia.org:https://en.wikipedia.org/wiki/Stellar_classification#Class_G
- Wikipedia.org. (2022, October 28). *Utahraptor*. Retrieved from <https://en.wikipedia.org:https://en.wikipedia.org/wiki/Utahraptor>
- Wikipedia.org. (2022, October 9). *Variable Specific Impulse Magnetoplasma Rocket*. Retrieved from https://en.wikipedia.org:https://en.wikipedia.org/wiki/Variable_Specific_Impulse_Magnetoplasma_Rocket
- Williams, M. S. (2021, September 11). *Engineers Are Creating a Real Space Elevator. Can They Succeed?*. Retrieved from <https://interestingengineering.com:https://interestingengineering.com/innovation/can-engineers-create-a-real-space-elevator>
- Woodford, C. (2021, November 15). *Gravity*. Retrieved from <https://www.explainthatstuff.com:https://www.explainthatstuff.com/gravity.html>
- Zhou, M. (2001, November 01). *Reactions of silicon dioxide with ammonia molecules*. Retrieved from https://researchgate.net:https://www.researchgate.net/publication/244133376_Reactions_of_silicon_dioxide_with_ammonia_molecules_Formation_and_characterization_of_the_SiO2-NH3_complex_and_the_H2NSiOOH_molecule
- Special thanks to these supporters for allowing their character to be used in the book:
- Renade Empor – Chapter 2, Section 3, Figure 11
 - Patchi – Chapter 2, Section 4, Figure 1, and Chapter 3, Section 1, Figure 8
 - NTM – Chapter 2, Section 4, Figure 4, and Chapter 3, Section 1, Figure 1
 - Alkac – Chapter 2, Section 4, Figure 2
 - Rhaaka – Chapter 2, Section 5, Figure 1
 - APersonThatIs – Chapter 2, Section 4, Figures 6 & 7
 - Eimillian – Chapter 2, Section 5, Figure 5
 - Tawani – Chapter 2, Section 5, Figure 4
 - Jhin Wonderlust – Chapter 3, Section 1, Figure 7
 - Misty Jinn – Chapter 3, Summary Figure 1
 - Renyu – Chapter 2, Section 4, Figure 2
- Note:** This is the “Public” edition. Some content was removed and can be found in the “Supporter” edition of the book. To find out what was removed and obtain access to the Supporter edition, donate to Todd Avali via Patreon or Ko-Fi, or contact the author for information!

